



Metal halide lamps

Instructions for the use and application

SEE THE WORLD IN A NEW LIGHT

OSRAM



Contents

1	Introduction.....	4
2	How a metal halide lamp works.....	5
2.1	Quartz discharge tube.....	6
2.2	Ceramic discharge tube (PCA = polycrystalline alumina).....	6
2.2.1	1st generation: cylindrical form.....	6
2.2.2	2nd generation: freely moldable ceramic, POWERBALL.....	6
3	Ballasts for discharge lamps.....	8
3.1	Inductive ballasts (chokes).....	8
3.1.1	American circuits for ballasts.....	9
3.1.2	Variation in supply voltage for adapted inductance.....	10
3.1.3	Influence of deviations in supply voltage.....	11
3.1.4	Capacitor for power factor correction.....	11
3.2	Electronic control gear (ECG).....	12
3.2.1	Structure and functioning of an electronic ballast.....	12
3.2.2	Service life and temperature.....	13
3.2.3	Advantages of operation with electronic ballast POWERTRONIC PTi.....	13
3.3	Influence of harmonic waves and corresponding filters.....	15
3.4	Brief voltage interruptions.....	16
3.5	Stroboscopic effect and flicker.....	17
4	Igniting and starting discharge lamps.....	19
4.1	External ignition units.....	19
4.1.1	Parallel ignition unit.....	19
4.1.2	Semi-parallel ignition unit.....	19
4.1.3	Superimposed ignitor.....	20
4.2	Warm re-ignition.....	20
4.3	Hot re-ignition.....	20
4.4	Ignition at low ignition voltage (Penning effect).....	20
4.5	Ignition at low ambient temperatures.....	20
4.6	Cable capacitance.....	21
4.7	Start-up behavior of metal halide lamps.....	21
5	Reducing the wattage of high intensity discharge lamps.....	23
5.1	Introduction.....	23
5.2	Wattage reduction techniques.....	23
5.2.1	Reducing the supply voltage.....	23
5.2.2	Phase control: leading edge, trailing edge.....	24
5.2.3	Increasing choke impedance or decreasing lamp current.....	24
5.2.4	Change in frequency for high-frequency mode.....	24
5.3	Recommendations for reducing the wattage in discharge lamps.....	25
5.3.1	Metal halide lamps.....	25
5.3.2	Dimming for other discharge lamps.....	25
6	Lamp service life, aging and failure behavior.....	26
6.1	Lamp service life and aging behavior.....	26
6.2	Storage of metal halide lamps.....	26
6.3	Failure mechanisms of metal halide lamps.....	26

6.3.1	Leaking arc tube.....	27
6.3.2	Increase in re-ignition peak.....	27
6.3.3	Broken lead or broken weld.....	28
6.3.4	Leaking outer bulb.....	28
6.3.5	Lamps that do not ignite.....	28
6.3.6	Breakage or differing wear of the electrodes.....	29
6.3.7	Scaling of the base / socket.....	29
6.3.8	Bursting of the lamp.....	29
6.3.9	Rectifying effect.....	29
6.3.10	Conclusions.....	31
7	Luminaire design and planning of lighting systems.....	32
7.1	Measuring temperatures, ambient temperature.....	32
7.1.1	General physical conditions for temperature limits for outer bulbs and pinches in metal halide lamps.....	32
7.1.2	2 Measurement with thermocouple.....	32
7.1.3	Measuring points for thermocouples in different lamp types.....	33
7.2	Influence of ambient temperature on ballasts and luminaires.....	36
7.3	Lamp holder.....	36
7.4	Leads to luminaires.....	37
7.5	Maintenance of lighting systems with metal halide lamps.....	37
7.6	Standards and directives for discharge lamps.....	39
7.6.1	Standards.....	39
7.6.2	Directives.....	41
7.6.3	Certificates.....	41
7.7	Radio interference.....	42
7.8	RoHS conformity.....	42
7.9	Optical design of reflectors.....	42
7.9.1	Condensation on the lamp.....	42
7.9.2	Projection of the condensate.....	42
7.9.3	Back reflection on the lamp.....	43
8	Light and colour.....	43
8.1	Night vision.....	44
8.2	Colour rendering.....	46
8.2.1	Test colours from standard DIN 6169.....	47
8.3	Light and quality of life.....	48
8.4	UV radiation.....	49
8.4.1	Fading effect.....	50
8.4.2	Protective measures to reduce fading.....	50
9	Disposal of discharge lamps.....	51
9.1	Statutory requirements.....	51
9.2	Collection, transport and disposal of discharge lamps at end-of-life.....	51
9.3	Ordinance on Hazardous Substances.....	51
10	List of abbreviations.....	52
11	Literature.....	53

1 Introduction

Metal halide lamps offer a number of advantages that favor their use in ever broader areas of application. These include high luminous efficacy, a long service life and good colour rendering. Because the light is

generated in a small space, the discharge lamps almost correspond to a spot light source, with advantages in terms of light control and brilliance of the illumination.

Table 1: The properties of metal halide lamps and resulting application areas

Requirements in the application	Property of metal halide lamps	High room, building			Shop	Street	Building illumination	Sports facilities
		Industry	Trade show	Foyer				
The height requires a lot of light	High luminous flux permits few fixtures light points	X	X	X			X	X
Changing lamps is difficult and expensive	Long service life with longer change intervals	X	X	X		X	X	X
Long operating hours	High efficacy and long service life	X		X	X	X	X	
Realistic reproduction of high value surfaces, pictures, products and TV images	Good colour rendering			X	X			X
High illuminance values	High luminous flux permits few fixtures light points				X			X
Luminaires should be small or discreet	Small dimensions permit compact luminaires			X	X		X	
High mounting heights and wide spacing demand precise light control	Small arc tubes permit very good light control					X	X	X

The means of generating light is technically complicated. The key principles regarding the operation of these lamps and instructions for their use are listed below.

These application instructions address a large number of users, such as luminaire designers, lighting planning engineers, operating device developers and retailers. Naturally, not all users will find all sections relevant, but the aim has been to cover the interests of as many users as possible.

2 How a metal halide lamp works

Similar to high-pressure mercury lamps or high-pressure sodium lamps, metal halide lamps also belong to the group of discharge lamps. Low pressure discharge lamps include fluorescent lamps and compact fluorescent lamps.

In discharge lamps, light is generated by a gas discharge of particles created between two hermetically sealed electrodes in an arc tube. After ignition, the particles in the arc are partially ionized, making them electrically conductive, and a "plasma" is created. In high intensity discharge lamps, the arc tube is usually enclosed in an evacuated outer bulb which isolates the hot arc tube thermally from the surroundings, similar to the principle of a thermos flask. But there are also some discharge lamps without outer bulbs, as well as lamps with gas-filled outer bulbs. In contrast to low-pressure discharge, there is high pressure and a high temperature in a discharge tube.

In an arc tube, gas discharge works through excitation of the luminous additives (metal halide salts) and the mercury is excited by the current flow. Visible radiation characteristic for the respective elements is emitted. The mixture of the visible radiation of the different elements results in the designed colour temperature

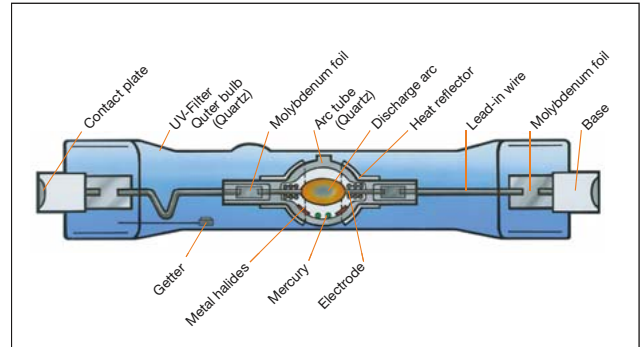

Fig. 1: An example of how a metal halide lamp works based on a double-ended lamp with a quartz arc tube.

and colour rendering for a particular lamp. In the operating state, the mercury evaporates completely. The other elements involved are present in saturated form at the given temperatures, i.e. they only evaporate in part; the rest is in liquid form at the coolest point in the arc tube. The fraction of the filling that has evaporated depends on the temperature of the coolest point on the arc tube wall and also varies for the different filling components. Changes to the temperature of the arc tube wall can change the composition of the metal halides in the discharge, thus also changing the colour properties of the lamp.

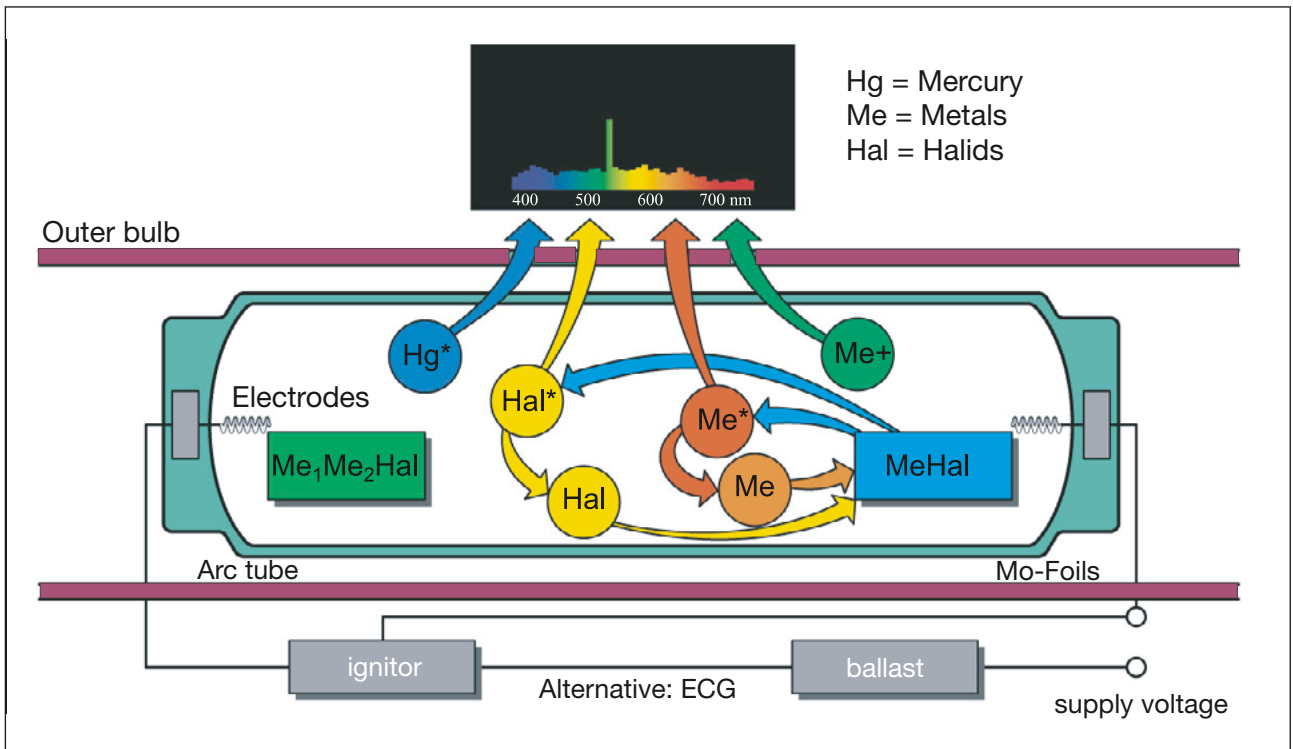

Fig. 2: Tasks of the metals [sodium (Na), thallium (Tl), indium (In), tin (Sn), lithium (Li), rare earths; dysprosium (Dy), holmium (Ho), thulium (Tm)]

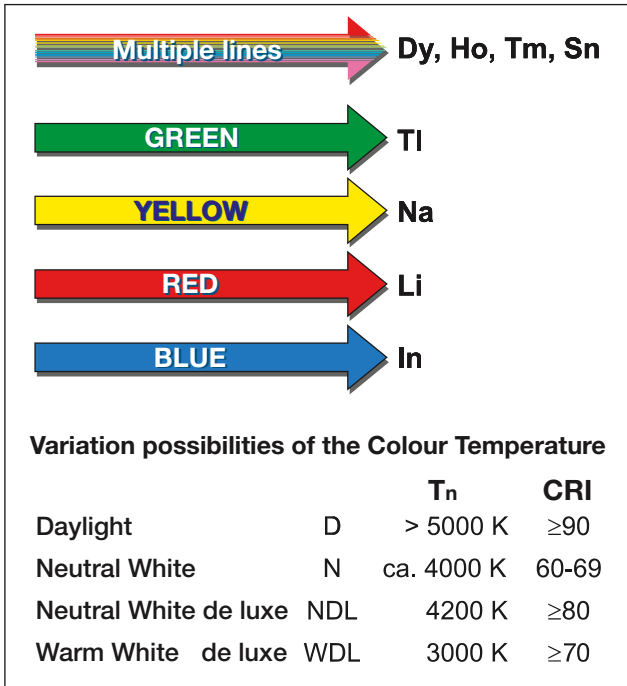

Fig. 2a: Generation of the desired Spectral Distribution Components in order to achieve high luminous Efficacies and good Colour Rendering

2.1 Quartz discharge tube

The discharge tubes in 1st-generation metal halide lamps are made of high purity quartz glass. This quartz material allows for stable operation at high temperatures, is resistant to sudden changes in temperature and is transparent. The well proven HQI lamps are produced in various different forms using this technology.

H	...	Hydrargyrum (Greek-Latin for mercury)
Q	...	Quartz
I	...	Iodide

- Well proven lamp technology
- Wide wattage range 70 W – 2000 W
- Colour temperatures up to 7250 K
- Good optical properties thanks to transparent discharge tube

2.2 Ceramic discharge tube (PCA = polycrystalline alumina)

The use of arc tubes made of ceramic material further enhanced some of the metal halide lamp's properties.

Ceramic can withstand higher temperatures than quartz glass. This permits higher wall temperatures thereby evaporating more of the metal halide salts into the gas arc and allowing for more efficient use of the chemicals. Ceramic lamps offer improved luminous efficacy and colour rendering as a result.

Ceramic arc tubes can be produced with smaller dimensional tolerances, reducing the variation in light-technical and electrical parameters.

Ceramic is less susceptible to attacks from the aggressive metal halide filling and is less permeable for filling particles, resulting in a considerably longer service life compared to quartz tube lamps.

Ceramic arc tubes are now available in various different forms: the original cylindrical version and the improved round version.

2.2.1 1st generation: cylindrical form

In the first version, the ceramic arc tube was designed in a cylindrical form, based on the production technology for the high-pressure sodium lamp. The arc tube was made up of cylindrical sub-sections sintered together. The arc tube consisted of a relatively thick plug at either end of the tube: this was necessary for the durability and functioning of the tube.

2.2.2 2nd generation: freely moldable ceramic, POWERBALL®

A second step with changed production technology permitted production of freely moldable tube geometries. This made it possible to produce round ceramic arc tubes with a constant wall thickness – the POWERBALL® arc tubes. The round form and constant wall thickness brought considerable advantages. The possibility of further increasing the wall temperature improves luminous efficacy and colour rendering. The absence of the thick plug at the end of the tube reduces light absorption in this area, resulting in a higher luminous flux with more uniform irradiation characteristics. There are fewer differences in the wall temperature between the various burning positions and therefore also smaller differences in colour between the burning positions. The reduced ceramic mass of the round tube enables the tube to heat up faster, reaching the photometric values more quickly. Similarly, when the lamp goes off, warm re-ignition is possible more quickly because the required cooler starting temperature for normal ignition devices is achieved faster.

The uniform wall thickness and round shape produce a more even temperature curve along the inner tube wall as shown in Fig. 3, based on the temperature shown in colours diagram. The steeper temperature gradient in the cylindrical ceramic favors chemical transport processes. During this process, aluminum oxide ceramic dissolves in the liquid metal halide melt and settles at cooler points of the arc tube. If erosion from the wall goes too far, this can lead to leakage in the tube, causing the lamp to fail. Failures due to so-called "ceramic corrosion" are thus less likely to occur in lamps with round ceramic tubes.

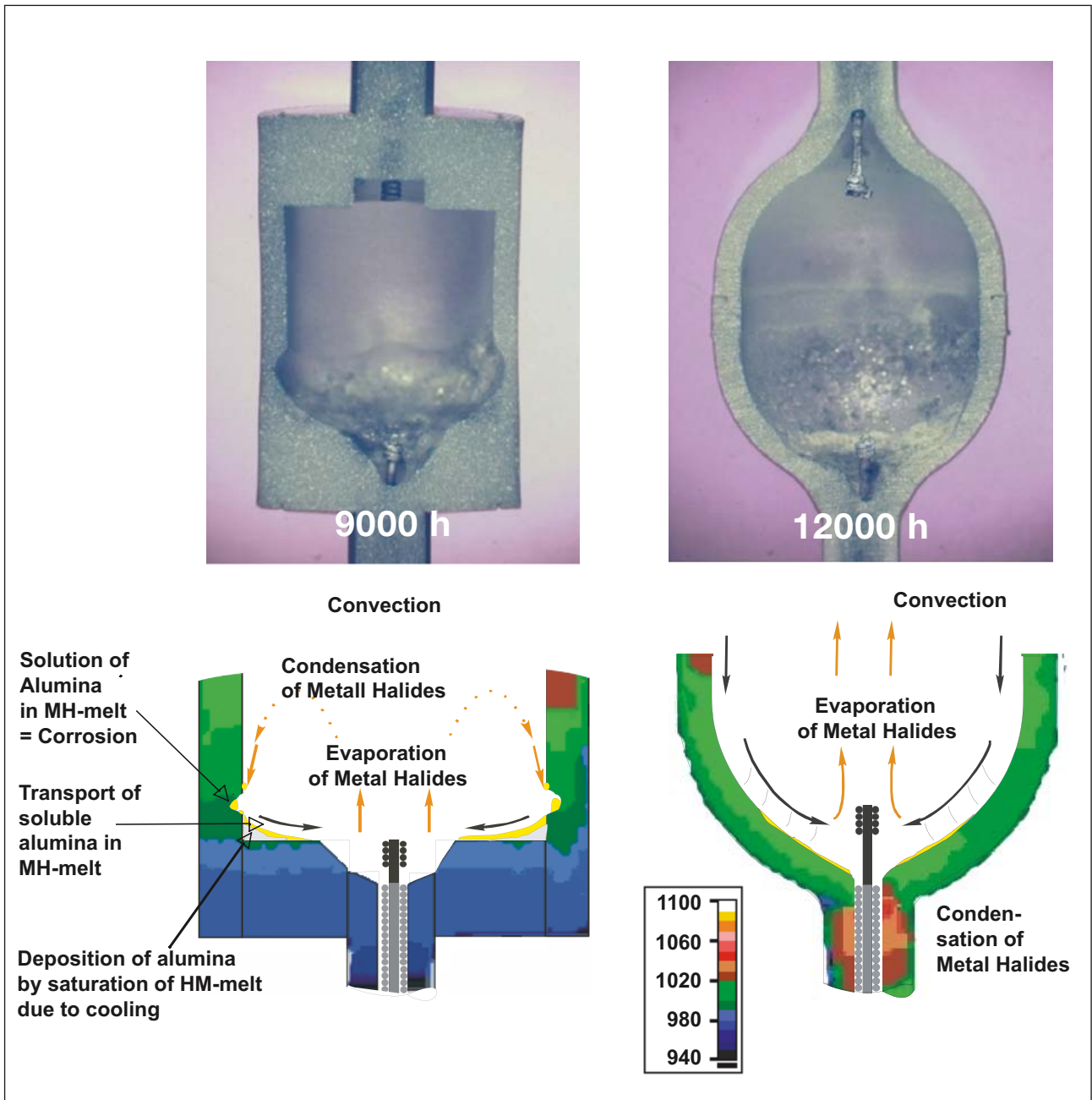

Fig. 3: Comparison of ceramic corrosion between the different tube forms

The advantages of POWERBALL® technology compared to cylindrical solutions

- Better maintained luminous flux throughout the service life
- Improved color rendering, particularly in the red
- Improved color stability during the service life
- More uniform operation independent of burning position
- More constant luminous intensity distribution
- Faster start-up behavior

3 Ballasts for discharge lamps

Since the discharge reacts to increasing lamp current with falling voltage (which would cause the current to rise indefinitely until the fuse blows or another part of the circuit fails), the lamp current must be limited by a ballast during operation. This usually consists of an inductive circuit (choke), although in rare cases up to 400 W capacitive circuits are also possible (although this usually results in a shorter service life). In the blended lamp (HWL), the resistance of the filament serves as a series resistor for the high-pressure mercury discharge lamp. In most cases, additionally to the current-limiting element, an ignition device is needed to start discharge (see chapter 4 "Ignition and starting discharge lamps").

In modern luminaires, an electronic ballast fulfils the function of igniting the lamp, limiting the lamp current and controlling the lamp wattage.

3.1 Inductive ballasts (chokes)

The voltage across the electromagnetic ballast increases as the current increases, therefore a stable working point can be achieved in the series connection of the discharge lamp and the choke.

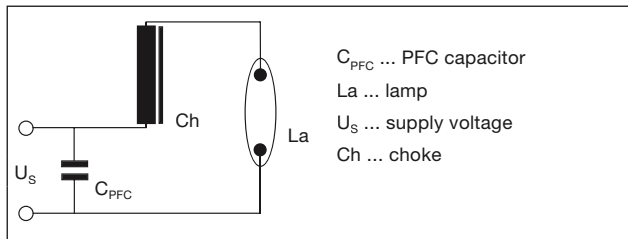

Fig. 4: Discharge lamp with inductive ballast (ignition unit has been left out, the various possibilities are featured in chapter 4 "Ignition and start-up of discharge lamps")

Describing the relationships of current and voltage requires a system of differential equations which cannot generally be solved. The following approximation formulas describe how the lamp current and lamp wattage depend on the relationship of lamp voltage to supply voltage [3]:

$$P_L = \frac{U_s^2}{Z} \cdot n \left(1 - \frac{n}{3}\right) \left[\left(1 - n^2\right)^{1/2} - 0,25n \right] \quad (\text{Gl. 4.1})$$

$$I_L \approx \frac{U_s}{Z} \left[\left(1 - n^2\right)^{1/2} - 0,25n \right] \quad (\text{Gl. 4.2})$$

whereby: $(1-n/3)$ approximation for the lamp power factor λ_L

P_L lamp wattage in W

U_s supply voltage in V

n ratio of lamp voltage U_L to supply voltage U_s

Z choke impedance

Charting the equations results in the curves shown in Fig. 5. The difference between lamp wattage and the product of lamp voltage and lamp current is called lamp power factor. It reaches values between 0.7 and 0.95 depending on the operating mode. The yellow curve was generated by using a higher lamp power factor λ_L [(to be more exact: $1.05 \cdot (1-n/3)$).

Typical voltage and current waveforms as shown in Fig. 6 show that while the current is (approximately) sinusoidal, voltage is not. After the current zero crossing, the voltage initially increases (so-called re-ignition peak) to then fall to a relatively constant value (saddle) (see also chapter 6.2.2 and Fig. 30). Voltage remains approximately the same beyond the maximum of the current, and has the same zero crossing as the current. So there are areas with high voltage which don't contribute to the wattage as the current at that point in time is nearly zero. This results in lamp power factors deviating from the value 1.

If the lamp voltage is equal to zero, the voltage drop across the choke is the entire supply voltage, and the choke short-circuit current is reached. This is the maximum current that can flow through the choke inasmuch as the current has no DC component (see chapter 6.2.9 for effects of direct current components).

The following curves are typical for 150 W and apply in the same way to other wattages.

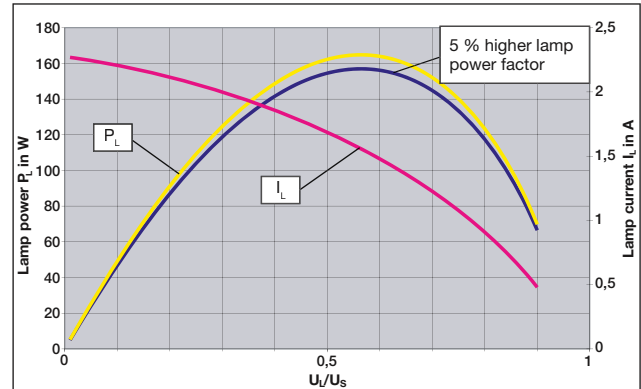

Fig. 5: Lamp current I_L , lamp wattage P_L over the ratio of lamp voltage to supply voltage U_L/U_s ; $Z=99 \Omega$ for a 150 W lamp

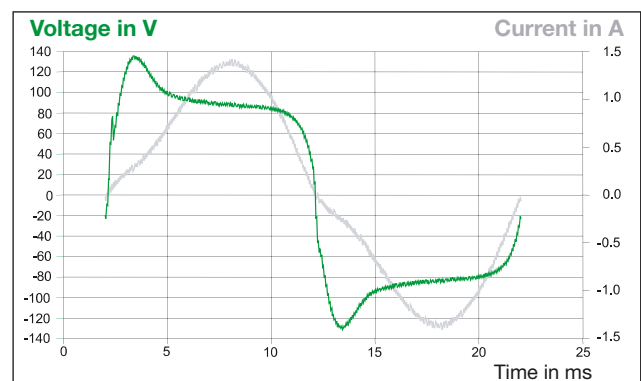

Fig. 6: Graph showing lamp voltage and current of a 150 W lamp when operated at a choke (applies in the same way to other wattages)

This lamp behavior results from the relatively flat zero crossing for sinusoidal current. When the current approaches zero, the plasma temperature decreases and the electrodes also cool down. The recombination of electrons with ions reduces conductivity. After the zero crossing, the conductivity is too low to take up the current that the choke wants to drive. As a result, the voltage through the lamp increases again significantly until the lamp “reignites”. The higher voltage results in a higher ionization rate that increases conductivity again so that voltage falls.

By contrast, current and voltage for the rectangular waveforms of an electronic ballast change significantly faster from positive to negative half-wave, or have a faster commutation times (see chapter 3.2 “Electrical ballasts (ECG)”), so that the plasma has little chance to cool down. The instantaneous voltage required from the electronic ballast is therefore significantly lower than for the choke. This is one of the advantages of electronic ballast, as one of the failure mechanisms of metal halide lamps is to extinguish due to high re-ignition voltage. The re-ignition peak of a lamp normally increases over the service life, and when it exceeds what the supply voltage momentarily can provide, there is no “re-ignition” and the lamp goes out (see also chapter 6.2.2 “Increase of the re-ignition peak”).

When operating on a conventional choke, the lamp wattage runs through a maximum depending on the lamp voltage (see Fig. 5). The maximum occurs for a lamp voltage of slightly more than half the supply voltage. Near the maximum the lamp wattage changes only slightly with the lamp voltage. During the lamp service life, the lamp voltage increases, as also shown in chapter 6 “Lamp lifecycle, aging and failure behavior”. In order for the lamp wattage to change as little as possible, the nominal value for lamp voltage is generally chosen near the maximum, therefore at about half the supply voltage.

The impedance of the choke is rated at a certain supply frequency and certain supply voltage. Deviations from the nominal supply voltage will result in a different ballast curve and a related different working point for the lamp and therefore different lamp wattage. To limit the associated greater spread in the lamp parameters, a maximum deviation of 5% from the nominal values is permitted in the short term for the supply voltage, or maximum 3% in the long term. For deviations over a longer period of time, suitable choke tap must be selected. Similarly, the choke impedance must not deviate from the nominal values by more than 2% (see also chapter 3.1.3 “Influence of deviations in supply voltage”).

- **Maximum permitted supply voltage deviations: 5% in the short-term, 3% in the long-term, use other tap on the choke if necessary.**
- **Maximum deviation of choke impedance 2%.**
- **The choke must be protected against overheating according to the standard (thermal fuse).**

As per the IEC 61167 standard, ballast units for MH lamps must be protected from overheating through rectification. This can be done e.g. with a thermal fuse (tested according to IEC 598-1, Annex C).

3.1.1 American circuits for ballasts

In this context it is important to note that the supply voltage in America has a different frequency (60 Hz). As the inductive resistance of the choke depends on the frequency, in this case it is important to use a designated ballast for the corresponding frequency. In addition, both lamps and ballasts in the USA are standardized by ANSI, the American National Standards Institute. To operate the systems correctly, lamps must be operated with corresponding ballasts. Ratings designations are required by ANSI to be marked clearly on all products, allowing users to clearly identify system agreement.

3.1.1.1 Autoleak transformer or high reactance auto-transformer

If the supply voltage is smaller than around twice the lamp voltage, as is the case, for example, in the USA or Japan, then the supply voltage must first be stepped up. A good way of doing this is use an autoleak transformer. Part of the secondary windings act as lamp choke. On the one hand, this saves on material, and on the other hand, a higher voltage (open-circuit voltage) is available to start the lamp. These types of ballasts are typically more economical than a constant wattage style ballasts at the expense of wattage regulation.

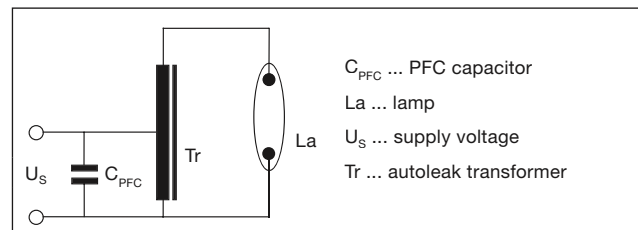

Fig. 7: Autoleak transformer

3.1.1.2 Constant wattage ballast

A constant wattage ballast such as those widely available in the USA consists of an autoleak transformer in series with a capacitor. The advantage of this circuit is the reduced impact of fluctuations in the supply voltage and the possibility of operating the lamp at supply voltages (110/120 V in the USA, 100 V in Japan) that lie within the range of the lamp voltage.

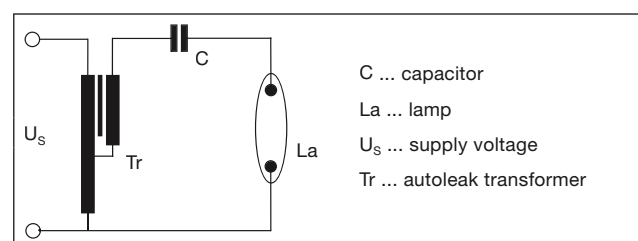

Fig. 8: Constant wattage ballast

3.1.2 Variation in supply voltage for adapted inductance

Some countries have supply voltages that permanently deviate from 230V. When using correspondingly adapted inductances, the following points must be taken into account.

3.1.2.1 Operation at supply voltage higher than 230 V with adapted choke impedance

An increase in supply voltage shifts the maximum of the choke characteristic curve (P_L over U_L/U_N). In the lamp voltage range of OSRAM lamps (approx. 100 V), the change in lamp wattage with changing lamp voltage is steeper. In addition, the maximum wattage that can be achieved with increasing lamp voltage is larger, as shown in Fig. 9. Normally, the lamp voltage increases with increasing service life (see also chapter 6 "Lamp service life, aging and failure behavior").

According to equation Eq. 4.1, wattage of about 150 W is achieved for a 150 W choke with a lamp voltage of 100 V. The maximum the lamp wattage can increase to for a lamp voltage of 150 V is 175 W. The higher achievable wattage can reduce the service life and possibly cause an increase of undesirable effects at the end of the service life (e.g. lamp explosion).

OSRAM lamps are generally designed to operate at 230 V supply voltage and undergo corresponding service life testing. There are, however, also systems at 400 V, e.g. for some discharge lamps > 1000 W. For these lamps, the following explanations apply in the same way. The use of high intensity discharge lamps is theoretically also possible at 277 V operating voltage with adapted impedance and ignition devices, although such operation is associated with considerable disadvantages.

- a) An increase in negative effects must be expected at the end of the service life, because wattage rises clearly above the nominal wattage when lamp voltage increases on account of the shifted choke characteristic curve. The increased wattage input for lamps with already aged arc tube wall can cause increased lamp explosion rates, for example. Operation in overload conditions will probably cause accelerated aging.
- b) The steeper characteristic $P_L(U_L)$ in the range of the normal lamp voltage causes a higher spread of the wattage and therefore of the photometric data, e.g. perceived colour variation.

We therefore discourage operating the lamps at 277 V supply voltage. Our lamps have been developed and undergone service life testing at 230 V supply voltage, so that we cannot assume any warranty for the service life behavior and photometric data for any deviating operation.

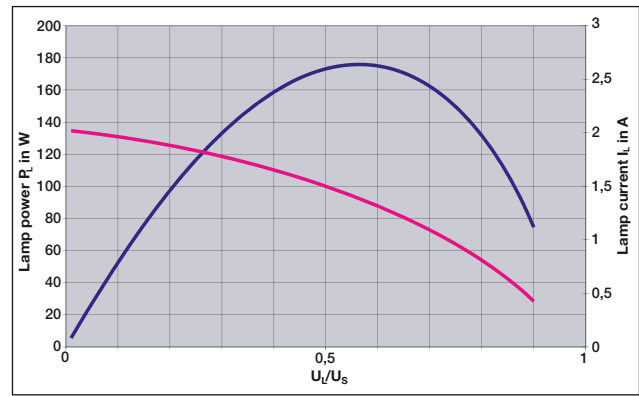

Fig. 9: Lamp current I_L , lamp wattage P_L over the ratio of lamp voltage to supply voltage U_L/U_s for $U_s=277$ V

3.1.2.2 Operation at supply voltage less than 230 V with adapted choke impedance

Supply voltages of less than 230 V **shift the maximum of the choke curve (P_L over U_L/U_s)**. Operation at 200 V supply voltage for example is more favorable than at 230 V with regard to the change in lamp wattage with lamp voltage. The $P_L(U_L)$ curve runs flatter in the normal range of lamp voltage. For lamp voltages exceeding 130 V Wattage falls again.

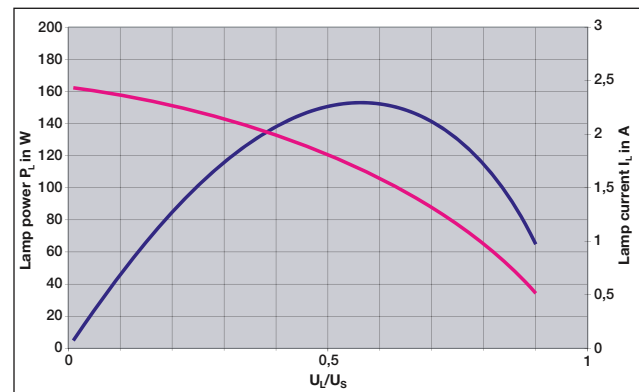

Fig. 10: Lamp current I_L , lamp wattage P_L over the ratio of lamp voltage to supply voltage U_L/U_s at $U_N=200$ V

There is a major drawback that with lower supply voltage, there is also less voltage available for re-ignition after the current has passed zero crossing. If the momentary supply voltage is lower than the re-ignition voltage, the lamp goes off. Normally, the lamp voltage and also the re-ignition peak increase with increasing service life (see also chapter 6, "Lamp service life, aging and failure behavior"). That means that a reduction in supply voltage causes a shorter service life in many lamps.

3.1.3 Influence of deviations in supply voltage

When operating metal halide lamps on a choke, the lamp parameters change depending on the supply voltage. To limit the associated variation in lamp photometrics, a maximum deviation in supply voltage of 5% from the nominal values for the supply voltage is permitted in the short term, or maximum 3% in the long term. For deviations over a longer period of time, suitable ballast tap must be selected. As choke impedance also influences the lamp parameters via the correspondingly adjusted lamp current, this is allowed to deviate from the nominal values by maximum 2%.

Remote mounting can also cause noticeable decreases in voltage (see also chapter 7.4 “Leads to luminaires”).

Long term reductions in lamp wattage cause the luminous flux to decrease, with a shorter service life and a deviation in colour from the nominal values, as also explained in chapter 5: “Wattage reduction in high intensity discharge lamps”.

If the supply voltage is too high, the arc tube is operated at too hot a temperature, causing increased blackening and a shorter service life.

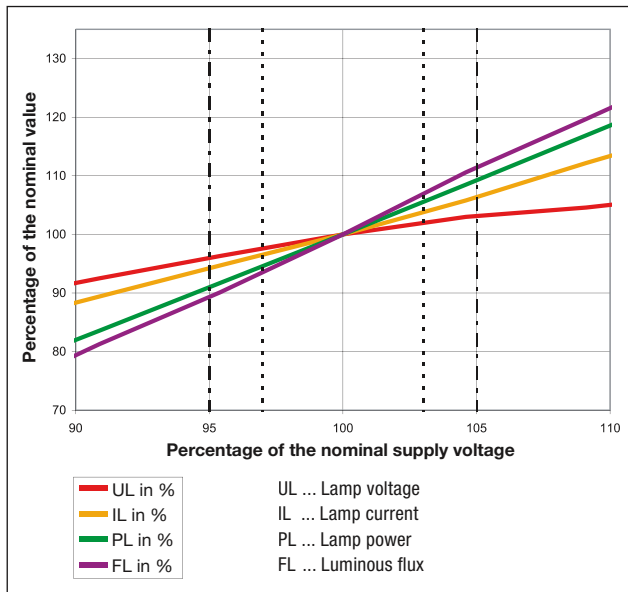

Fig. 11: Lamp parameters of a typical OSRAM HQI® lamp over supply voltage

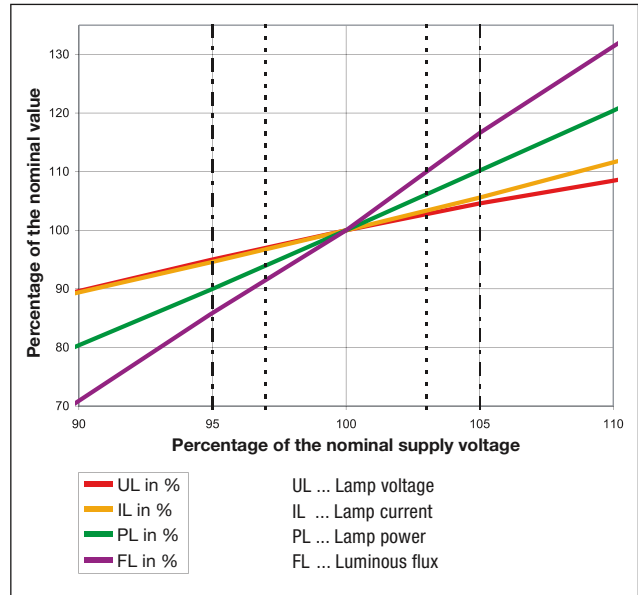

Fig. 12: Lamp parameters of a typical OSRAM HCL® lamp over supply voltage

3.1.4 Capacitor for power factor correction

The capacitor for power factor correction is necessary to correct the power factor of the system when operating discharge lamps at electromagnetic ballasts. Inductively stabilized discharge lamps achieve power factors of only about 0.5 because of the dephased current flow. The power factor of a load is defined as the ratio of effective power to the apparent power actually withdrawn from the grid (kW to kvar) and is referred to as $\cos \varphi$. The apparent power comprises the effective power used by the consumers to create e.g. heat or mechanical energy and the idle power that is used to develop magnetic or electric fields of inductivity and capacity. However the latter flows back into the grid after a half cycle length, i.e. it is not actually “used”. The closer $\cos \varphi$ is to one, the smaller is the share of wattless power withdrawn from the grid. A higher share of wattless power results in a higher flow in current for which the supply lines have to be rated. Similarly, power dissipation in the supply lines increases in a square progression with the current. In order to achieve the values demanded by the utility companies of more than 0.85, a grid parallel capacitor must be selected according to the lamp or choke current to approximately correct the shift in phase. By including an exactly calculated capacitor, the inductive wattless load required by an electric consumer can be offset with a capacitive wattless load. It is thus possible to reduce the wattless power withdrawn from the grid; this is called the power factor correction or wattless power compensation.

The capacitors are differentiated as follows, depending on the arrangement and form of use:

INDIVIDUAL OR FIXED COMPENSATION, where the inductive wattless power is corrected directly where it occurs, relieving the strain on the leads (typical for individual consumers usually working in continuous mode with constant or relatively large wattage – discharge lamps, asynchronous motors, transformers, welding equipment, etc.)

The parallel capacitor has no influence on lamp behavior.

GROUP COMPENSATION, where one joint fixed capacitor is allocated to simultaneously working inductive consumers, similar to individual correction (motors located close together, discharge lamps). Here again the strain on the leads is relieved, but only up to the point of distribution to the individual consumers. Under unfavorable conditions, resonance can be caused in two-phase grids.

CENTRAL COMPENSATION, where a number of capacitors are connected to a main or sub-distribution station. This is the normal procedure in large electrical systems with changing load. Here the capacitors are controlled by an electronic controller which constantly analyzes the demand for wattless power in the grid. This controller switches the capacitors on or off to correct the current wattless power of the total load and thus reduce overall demand in the grid.

Capacitor for power factor correction values are stated for every lamp type in the Technical Information and can also be calculated using the following equation.

$$C_{PFC} = \frac{1}{2 \times \pi \times f_s \times U_s^2} \times \left(\sqrt{U_s^2 \times I_L^2 - P_W^2} - (P_W \times \tan \varphi_K) \right) \text{ Eq. 4.3}$$

C_{PFC} in F	Capacitance of the capacitor for power factor correction
U_s in V	Rated supply voltage
f_s in Hz	Supply frequency
I_L in A	Lamp rated current
P_W in W	Total active power (lamp rated wattage plus choke loss wattage)
φ_K	Tolerable or desirable phase difference between the fundamental waves of the supply voltage and the supply current.

But this only corrects the power factor for the fundamental wave. Phase difference remains for distortion, i.e. the harmonic waves, between current and voltage. For this reason, the overall power factor can also only reach values between 0.95 and 0.98 in practice.

A higher level of harmonic waves can cause resonance effects and destroy the lamp. A power factor close to 1 is to be avoided as this can cause resonance between the choke and correction capacitor.

While a discharge lamp is starting up, the power factor undergoes significant changes in value. After ignition, the lamp voltage is still very low with current higher than in steady state. This is why the power factor in this state is still low (inductive). While lamp voltage increases and the lamp current falls, the power factor increases to its nominal value of 0.85 – 0.9.

As discharge lamps age, it is normal for lamp voltage to increase, causing the lamp current to fall according to

the ballast curve. Because the capacitor for power factor correction is rated for a specific lamp and choke current, the power factor varies according to lamp current. For an extremely high lamp voltage, the choke current is so low that capacitive current exceeds the inductive current and the complete circuit becomes capacitive.

Under certain conditions, audio frequency central control systems have to be considered during installation. In these cases, suitable audio frequency attenuation chokes are to be provided. This kind of system is still sometimes used for day/night circuits in street lighting, although directional radio systems are finding increasing use here.

3.2 Electronic control gear (ECG)

Together with conventional ballasts, the use of electronic ballasts has meanwhile become widely accepted practice, particularly for interior lighting.

Electronic ballasts offer clear advantages compared to conventional ballasts. The main advantages include in particular simplified handling (e.g. lighter ballasts), lower energy consumption, a positive impact on lamp service life and light quality, and, last but not least, controlled and reliable shutdown of lamps at the end of the service life.

Basically, most of the technical information provided in this manual applies to both conventional ballasts and electronic ballasts. This refers for example to wiring requirements, wattage-reduced operation of MH lamps or instructions for luminaire design.

But in addition, there are also considerable differences between operation on an electronic or magnetic ballast. The following section briefly explains the main differences and their effects.

3.2.1 Structure and functioning of an electronic ballast

Electronic ballasts mainly consist of units with rectangular current and voltage. In principle, it is also possible to operate the lamps with high-frequency sinusoidal current similar to the fluorescent lamp. In any case, it is important to ensure that no acoustic resonances occur as these may result in arc instability (lamp flicker) and in severe cases, lamp rupture.

3.2.2 Service life and temperature

There is a significant difference between conventional and electronic ballasts particularly with regard to the service life and thermal behavior of the units.

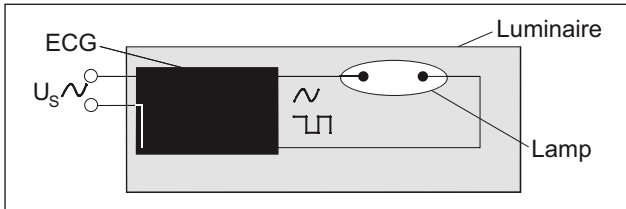

Fig. 13: Simplified circuit diagram showing the electronic operation of high intensity discharge lamps

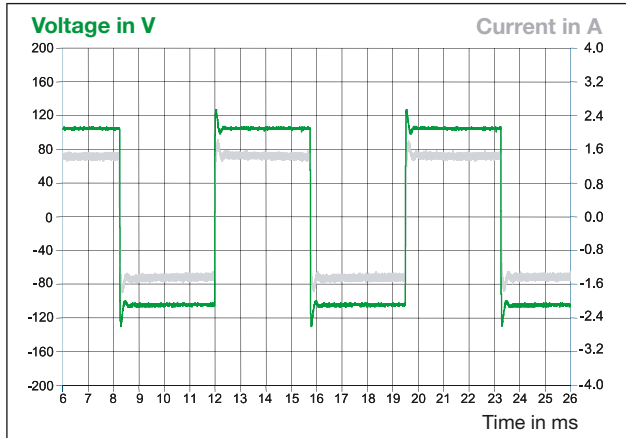

Fig. 14: Current and voltage of a metal halide lamp operated on a rectangular electronic ballast

For a conventional ballast, it can be presumed that the service life is defined by the choke temperature t_w . A 10 °C increase in the t_w temperature means that the service life is halved.

In electronic ballasts, these circumstances are far more complicated. The mortality rate of individual components, the circuit design and above all the electronic load and the temperatures at which the units are operated have a considerable influence on the service life behavior.

This is why the nominal service life of electronic ballasts is stated in combination with a failure probability. For example, all units in the product family POWERTRONIC® PTi have a nominal service life of 40,000 hours with failure probability of maximum 10% when operated at the maximum permissible temperatures.

The service life of electronic ballasts is influenced directly by the temperature at which the units are operated. This is why 2 temperature values are defined to describe the thermal behavior. The ambient temperature t_a describes the temperature immediately surrounding the unit and thus prevailing around the electronic components. To be clear, this is not the room temperature or the ambient temperature of the luminaire.

When an electronic ballast is fitted in a luminaire, the real ambient temperature t_a of the ballast can only be measured with great difficulty and at great effort. This is why a second temperature has been stipulated: the t_c temperature. Basically this is the casing tempera-

ture which can be measured by a thermocouple at a set point – the t_c point – and is defined as maximum permissible temperature at which safe operation of the electronic ballast is still guaranteed. In addition, the t_c temperature is set in relation to the ballast service life. That means that the measured t_c temperature permits very precise conclusions as to the anticipated service life of the electronic ballast.

OSRAM's HID electronic ballast for example principally reaches its full nominal service life at the maximum permitted t_c temperature. In practice, this means that any temperature levels below the t_c temperature always prolong the effective service life. As a rule of thumb, it can be presumed that a temperature 10 °C below the printed maximum t_c temperature will double the service life of the electronic ballast.

However, it is not advisable to use only the absolute maximum tolerable t_c value for conclusions regarding the quality and service life of an electronic ballast. This is because on the one hand, the position and therefore indirectly also the value of the t_c point can be freely defined by every electronic ballast manufacturer. On the other hand, the rule of stating the nominal service life at the maximum permitted t_c temperature has not yet become established throughout the electronic ballast industry. In practice this means that many electronic ballasts only achieve approx. 50% of their nominal service life at maximum t_c temperature.

Nominal service life (B10): max. 10% of the electronic ballasts have failed

A serious evaluation of the electronic ballast service life is only possible by comparing the electronic ballast ambient temperature t_a with the corresponding service life.

Comparison of the service life using only the t_c temperature is not appropriate.

3.2.3 Advantages of operation with electronic ballast POWERTRONIC® PTi

The following table provides an overview of the advantages of operating lamps with the electronic ballast. The corresponding values and statements are based on tests and experience with POWERTRONIC® PTi ballasts, so that they cannot necessarily be transferred 1:1 to ballasts of other makes.

In comparing the conventional and the electronic ballast, the performance of the conventional ballast constitutes the reference parameter and is given a value of 100. This is also based on the fact that the lamp parameters are defined with the reference conventional ballast.

For more details, please refer to the POWERTRONIC® Technical Guide – Electronic control gears for metal halide lamps.

	Magnetic ballast	Electronic ballast POWERTRONIC®
Energy consumption	100	10 to 15% savings over the service life
Lamp service life	100	Up to 30% longer depending on lamp type and kind of use
Lamp start-up	Depends on type: usually approx. 60 to 90 sec. to reach 90% of the luminous flux level	Up to 50% faster
Colour stability	Colour variation possible	Clearly reduced scattering; initial and over service life
Cut-out at end of lamp service life	Not available or only simple cut-out mechanisms	Permanent parameter control, intelligent cut-out mechanisms
Ignition cut-out	Only with timer ignition units	Ignition time limited to 18 min
Light flicker	Visible flicker	Flicker-free thanks to 165 Hz operation
Consistent wattage	Increase in wattage over service life, also dependent on fluctuations in temperature and supply voltage, and on lead length	± 3% over the entire service life, regardless of fluctuations in temperature and supply voltage or lead length
Handling	3 components, complicated wiring	1 unit, simple wiring
Size and weight	Heavy, several components, large in some cases	Light and compact
Power factor correction (PFC)	0.5 – 0.95, considerable aging fluctuations	> 0.95
Noise development	Clearly audible humming possible	Almost noiseless
Bidirectional data exchange	Not possible	Generally possible

The main advantages of electronic ballasts are described in greater detail in the following section.

3.2.3.1 Reducing energy consumption

Compared to conventional ballasts, electronic ballasts can considerably reduce energy consumption over the service life. The energy savings result from two factors:

- 1) Unit power dissipation:
In conventional ballasts a large amount of energy is lost in dissipated heat on account of the design. By contrast, electronic ballasts have a low-loss design with top quality components, reducing dissipation to less than 10% of the nominal power.
- 2) Increase in wattage over service life:
The system wattage with conventional ballasts fluctuates significantly over the service life of the lamp. This results from the change in lamp voltage, which can increase by up to 30% throughout the service life (see also chapter 3.1.2), resulting in considerable fluctuations in lamp wattage.

By contrast, electronic ballasts operate the lamps always with constant wattage throughout the entire service life. The maximal tolerated fluctuation is 3%. This means for example that for a 70 W ceramic arc tube lamp, the electronic ballast constantly provides the lamp with the rated 73 W.

3.2.3.2 Lamp service life and cut-out at the end of the service life

A detailed description of the lamp service life and failure behavior using conventional ballasts can be found in chapter 6.

Electronic ballast operation also offers considerable advantages in terms of lamp service life and cut-out behavior at the end of the service life.

Comprehensive laboratory tests and extensive practical experience show that operation on electronic ballasts has a significantly positive influence on the lamp service life. Precise but gentle lamp ignition, a more stable thermal balance thanks to constant wattage

supply and, above all, a clearly reduced tendency to go out by avoiding re-ignition peaks all lengthen the lamp economic life for ceramic arc tube lamps by up to 30% on average.

The electronic ballast also shows its strengths at the end of the lamp service life. The ignition time limit ensures that old lamps, where stable operation is no longer possible, are not subject to endless ignition attempts. After max. 18 minutes and precisely defined ignition intervals, the POWERTRONIC® ECG cuts out automatically. If a lamp goes out 3 times, the electronic ballast also cuts out. This avoids interfering, flickering light, prevents EMC load on the cables and also an excessive load on the electronic ballast itself.

Permanent monitoring of parameters such as lamp voltage or lamp current by the integrated micro-controller and alignment with pre-defined nominal values also makes it possible to turn lamps off well before they reach critical or undefined conditions which often can hardly be managed.

3.2.3.3 Light quality, light colour, drop in light output, start-up

HID lamps with electronic ballasts offer considerably improved colour quality, both when initially installed and throughout the service life.

The constant wattage supplied to the lamp by the electronic ballast can compensate for differences in light quality resulting for example from production tolerances or differing aging states. The result is visibly more even light colour and a more uniform chromaticity coordinate.

Similarly, supply voltage fluctuations or the length of the power leads are no longer relevant when using an electronic ballast, as the constant wattage supply to the lamp means these have no effect.

Lamp electrodes cool down to a lesser extent with the rectangular electronic ballast thanks to the steep electrical transitions through the zero crossing. Less cooling down results in reduced sputter effects of the electrodes, which in turn means less bulb blackening. The more constant, and on average slightly higher, lamp plasma temperature also produces 3% to 5% more luminous efficacy, which also has a positive influence in luminous flux behavior in addition to reduced blackening effects.

Electronic ballasts also have a much faster start-up behavior than magnetic ballasts. Fig. 24 in chapter 4.7 for example clearly shows that a double-ended quartz lamp operating with an electronic ballast already produces more than 90% of its max. luminous flux after approx. 40 seconds. The same luminous flux level with a conventional ballast takes at least 25 to 30 seconds longer. This at least 50% faster start-up at the electronic ballast is due to the higher start-up

current of the electronic ballast, producing a higher wattage input into the lamp which therefore heats up more quickly.

3.2.3.4 Size, weight and handling

Electronic ballasts combine ignition component, compensation component and choke in one unit. This 3-in-1 combination clearly reduces the installation workload, the risk of installation errors and the need to replace individual faulty units. Multi-lamp electronic ballasts (e.g. 2x35 W or 2x70 W) duplicate these advantages because to connect to 2 luminaires, only one power lead is required.

Electronic ballasts are also lightweight. They weigh 50% to 60% less than magnetic ballasts, which of course offers direct advantages in terms of luminaire design: they can be sleeker in structure; a wider range of materials can be used, and a lighter load can be placed on the fastening components.

3.2.3.5 Bidirectional data transfer

Intelligent electronic units will in the future offer completely new possibilities of controlling and monitoring lighting systems, thanks to bidirectional data transfer. Features such as querying the lamp or ballast status, integration in Building Management Systems (BMS) and central or local actuation and management of lighting solutions will not only bring a clearly expanded range of functions but also optimize maintenance and repair work. In the medium term, it is quite conceivable to see developments here similar to those in low-pressure discharge technology.

- **Electronic ballasts are state of the art.**
- **Electronic ballasts can be used to achieve significant increases in quality, reliability and safety of lighting systems with metal halide lamps.**
- **Most new MH lighting installations today are already equipped with electronic ballasts.**

3.3 Influence of harmonic waves and corresponding filters

The development of modern semiconductor technology with a significant increase in the number of consumers with solid state switches and converter controllers unfortunately results in undesirable side-effects on the AC voltage supply by causing considerable inductive wattless power and non-sinusoidal current.

A typical converter current consists of various superimposed sinusoidal partial currents, i.e. a first harmonic with the supply frequency, and a number of

so-called harmonic waves whose frequencies are a multiple of the supply frequency (in three-phase supplies these are mainly the fifth, seventh and eleventh harmonic waves).

These harmonic waves increase the current of the capacitor for power factor correction, as the reactance of a capacitor decreases with increasing frequency.

The increasing capacitor current can be accommodated by improving the design of the capacitor, but this does not eliminate the risk of resonance phenomena between the power capacitors on the one hand and the inductance of the feeding transformer and the grid on the other.

If the resonance frequency of a resonance circuit consisting of power capacitors and inductance of the feeding transformer is near enough to the frequency of a harmonic wave in the grid, this resonance circuit can amplify the oscillation of the harmonic waves and cause immense overcurrent and overvoltage.

The harmonic wave contamination of an AC voltage supply can have some or all of the following effects:

- early failure of capacitors
- premature triggering of protective switches and other safety devices
- failure or malfunction of computers, drivers, lighting installations and other sensitive consumers
- thermal overload of transformers caused by increased iron losses
- overload of the neutral conductor (particularly by the 3rd harmonic wave)
- shattering or bursting of discharge lamps
- thermal overload of the lamp choke due to resonance between choke and capacitor for power factor correction. The effects can be similar to asymmetrical mode (see chapter 6.2.9), which is why the use of a choke with thermal protection can also protect the luminaire from burning.

The installation of so-called choked capacitors (capacitor in series with a filter choke) aims at forcing the resonance frequency of the grid below the frequency of the lowest prevailing harmonic wave. This prevents a resonance between the capacitors and the grid and would thus also prevent the amplification of the harmonic currents. This kind of installation also has a filtering effect by reducing the level of voltage distortion in the grid. It is therefore recommended for all cases where the wattage share of the loads that generate harmonic waves is more than 20% of the total wattage. The resonance frequency of a choked capacitor always lies below the frequency of the 5th harmonic wave.

In the electronic ballast OSRAM POWERTRONIC® PTi, the influence of harmonic waves on the lamp is kept extensively at bay by the ballast design which comprises an intermediate circuit. The immunity of the PTi input stage to line-related interference is safeguarded by tests according to the IEC 61000 standard.

Such line-related interference includes e.g.:

- burst as per IEC61000-4-4, 1000V peak, repetition frequency 5kHz, low-energy pulse
- current feed as per IEC61000-4-6, frequency range 0.15-80MHz, 3Vrms
- surge as per IEC61000-4-5, 1000V symmetrical, 2000V asymmetrical, high-energy pulse
- voltage interruptions as per IEC61000-4-11
- voltage fluctuations

3.4 Brief voltage interruptions

When the lamp current falls, the recombination rate starts to exceed the ionization rate, causing a reduction in plasma conductivity. This occurs with magnetic ballasts in every half-wave on passing the zero crossing and results in the so-called re-ignition peak. When recombination of the charged particles has progressed far enough, the remaining quantity of charge carriers is not sufficient enough to generate an adequate quantity of new charge carriers when the voltage increases again – the lamp goes out. The high pressures in the arc tube mean that the ignition voltage is now no longer sufficient to re-ignite the lamp. It has to first cool down for a few minutes before it can ignite again (see also chapter 4.2 “Warm re-ignition”).

When the supply voltage is interrupted, both the length and depth of the interruption (100% for complete interruption) and the phasing of the interruption are important. Older lamps with their increase in lamp voltage and higher re-ignition voltage are more sensitive than unaged lamps. The capacitor for power factor correction can act as voltage source during voltage interruptions, at least in the short term, and extend the time in which a voltage interruption is tolerated before the lamp goes off. Voltage interruptions just before the zero crossing are more serious, because the plasma has already cooled down significantly.

3.5 Stroboscopic effect and flicker

Operation of a metal halide lamp on a magnetic ballast under supply voltage with 50 Hz frequency results in periodic fluctuation of the luminous flux with double the supply frequency. When the current flow drops near the zero crossing, the plasma also has far less radiation. But even on passing the zero crossing, the luminous flux does not reach zero so that the plasma still has on-going radiation.

The human eye reacts with differing sensitivity to varying flicker frequencies, and can, for example, no longer perceive fluctuations in luminous flux above 100 Hz. Literature provides differing ways of depicting the sensitivity of the human eye for periodic luminous flux fluctuations at various frequencies. Fig. 17 shows an example according to Kelly and Henger [1].

When operating at 50 Hz, the luminous flux or intensity fluctuates with wattage, i.e. with 100 Hz as shown in Fig. 15. Literature uses various equations to evaluate changes in luminous intensity that can be perceived by the human eye. Flicker is evaluated according to EN 50006 standard, for example, with a flicker factor F_{10} as

$$F_{10} = \sqrt{\sum_i m^2(f_i) G^2(f_i)}$$

whereby $m(f_i)$ = time-dependent modulation depth of the luminous intensity
 G = filter curve for flicker sensitivity depending on flicker frequency

According to Afshar [2], adapting the evaluation also to short-term changes and implementation in a filter for a light signal, such as in Fig. 15, results in values for the flicker factor as shown in Fig. 16. The perceptibility threshold is assumed to be 1. The values in this example remain below 1, i.e. no visible changes can be perceived in the light.

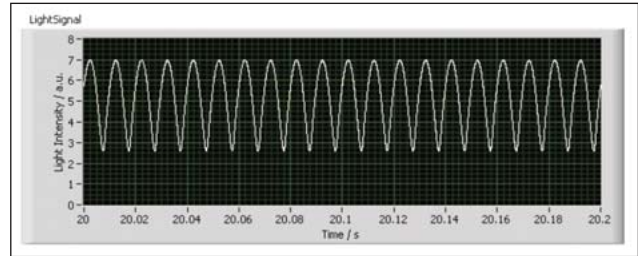

Fig. 15: Luminous intensity of a metal halide lamp at 50 Hz choke operation, shown in arbitrary units

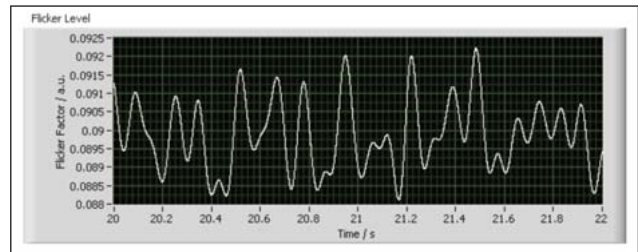

Fig. 16: Flicker factor calculated from the luminous intensity signal for a metal halide lamp at 50 Hz choke operation, shown in arbitrary units

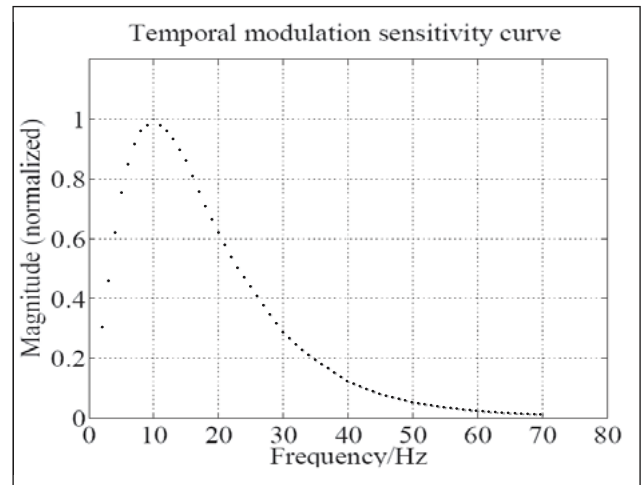

Fig. 17: Eye sensitivity curve for flicker as per Kelly 1960 and Henger 1985

There is a delay of just a millisecond between the current maximum and the luminous flux maximum as shown in the following drawing.

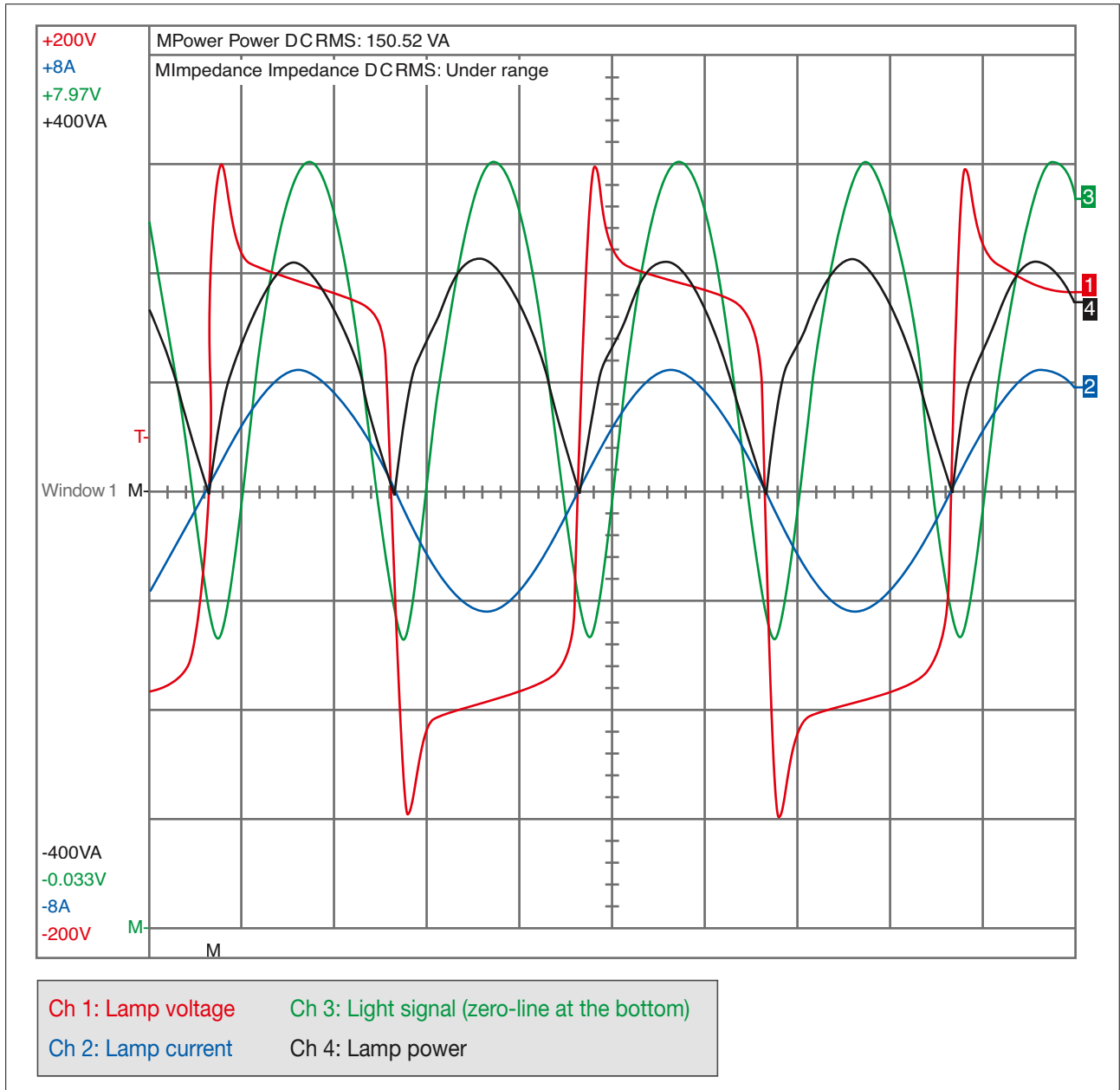

Fig. 18: Time curve for light signal and the electric parameters of a metal halide lamp

In fast-moving or rotating objects, the stroboscope effect can cause an optical illusion that the object is moving more slowly or in the opposite direction or even at a standstill.

Stroboscope effects can be reduced or ruled out by operating luminaire groups on three different phases or by using electronic ballasts.

4 Igniting and starting discharge lamps

Some discharge lamps do not require an external ignition unit, as the supply voltage is sufficient to ignite the lamp or because the lamp has an integrated ignition unit. These lamps must **not** be used in installations with an external ignition unit or they will fail prematurely due to internal arcing.

All other discharge lamps must be ignited by an additional unit. Ignition units or circuits of varying types are used for this purpose.

At room temperature, the filling particles are still present in solid form (metal halides or amalgam) or in liquid form (mercury). The arc tube contains the start gas, usually an inert gas such as argon or xenon, between the electrodes. The insulating gas filling in the arc tube must be made conductive in order to generate hot plasma. This is carried out by high-voltage pulses generated by a separate ignition unit or by the ignition unit in an electronic ballast. Constantly available free charge carriers (electrons) are accelerated by high voltage, providing them with sufficient energy to ionize atoms on impact and generate more free charge carriers. This process, similar to an avalanche, finally produces conductive hot plasma within which the current flow excites the partly evaporated metal halide filling such that light is radiated.

The ignition voltage required to generate a breakdown between the electrodes depends on the spacing between the electrodes, the filling pressure of the gas between the electrodes and the type of gas. Examples for using these principles include the use of auxiliary electrodes or the use of Penning gases (see chapter 14.4 "Ignition at low ignition voltage (Penning effect)").

The sockets and cables must be suitably designed for the high ignition voltages. In particular with the E27 sockets for single-ended screw base discharge lamps, care must be taken that a similar socket (E27) for incandescent lamps is not used, which does not meet the requirements.

When lamps are defective or no lamp is inserted, continuous operation of the ignition unit can possibly damage the ignition unit or the luminaire. It is therefore advisable to switch the ignition unit off for a period of time after failed ignition, or to use an ignition unit with timer function.

Preference should be given to using a timer ignition unit.

4.1 External ignition units

4.1.1 Parallel ignition unit

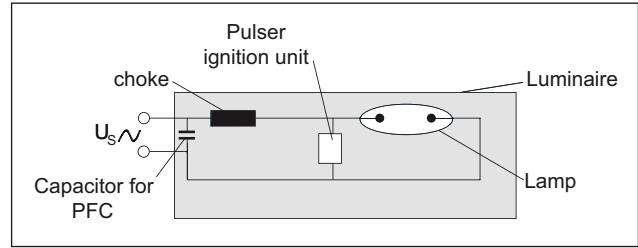

Fig. 19: Simplified circuit diagram for conventional operation of high intensity discharge lamps with pulse ignition unit

With a pulse ignition unit, the choke must be insulated for its surges. The pulse ignition units can normally take a load of 1000 pF, permitting lead lengths of about 15 m between lamp and choke. During ignition, the lead carries high voltage from the choke to the lamp so that care must be taken to ensure that the supply lead, socket and luminaire are adequately insulated for the corresponding high ignition voltage. This type of ignition unit is used in single phase grids.

4.1.2 Semi-parallel ignition unit

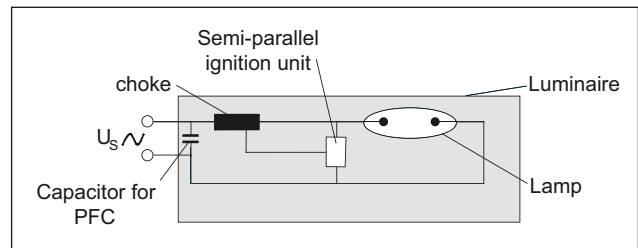

Fig. 20: Simplified circuit diagram for conventional operation of high intensity discharge lamps with a semi-parallel ignition unit

In the semi-parallel ignition unit, part of the choke windings is used to transform the ignition pulses. This means the choke must be adequately insulated for the high voltage and have a tap for the ignition unit. As with pulse ignition units, the ignition unit can generally take 1000 pF or approx. 15 m lead length, and the connection lead between choke and lamp must be insulated for the corresponding voltage levels. A capacitor with minimum capacitance depending on the unit must be provided for compliance with the EMC of the ignition unit.

4.1.3 Superimposed ignitor

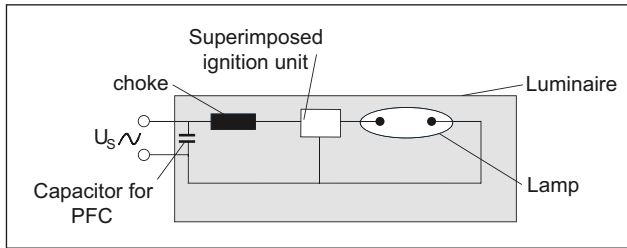

Fig. 21: Simplified circuit diagram for conventional operation of high intensity discharge lamps with a superimposed ignition unit

In a superimposed ignition unit, the high voltage is only present at the lamp outputs of the unit. Depending on cable and structure, ignition units of this type can normally take loads of 100 pF, corresponding to a lead length of about 1.5 m.

4.2 Warm re-ignition

Normal ignition voltages in the range up to 5 kV do not permit immediate re-ignition of a lamp which is still hot. The high operating pressures demand ignition voltages of e.g. 25 kV. If a lamp goes out for instance because of a brief interruption in the supply voltage, it must cool down for a few minutes (for lamp wattages ≤ 150 W) until the falling pressure in the arc tube permits re-ignition for normal ignition units in the 5kV range. Higher wattage levels require considerably longer cooling down periods because of the higher thermal capacity. The cooling down process depends also on the ambient temperature and the luminaire. A narrow, hot luminaire prolongs the cooling down procedure, delaying re-ignition of the lamp.

This cool down time must be considered for ignition units with a timer cut-out which are designed to shut off after a certain period of time with failed ignition. The design intent assumes that the lamp is defective or not inserted. The selected timer period must be sufficient to allow the lamp enough time to cool down following a power interruption so that lamp re-ignition is again possible. The warm re-ignition times of the POWERBALL® are under 10 minutes, far shorter than those of the cylindrical version.

The timer period for ignition units with warm re-ignition must be appropriately long enough.

4.3 Hot re-ignition

High ignition voltages of 16 to 60 kV are necessary for immediate re-ignition of hot metal halide lamps (hot re-ignition) on account of the high vapor pressures. The lamp, sockets and luminaire must be designed for these high voltages, and suitable ignition units must be used. There are two versions of hot re-ignition units

with symmetrical and asymmetrical ignition pulses. In the asymmetrical units, care must be paid to correct polarity of the lamp connections!

At present, hot re-ignition is permitted for double-ended quartz lamps (with a few exceptions). As far as ceramic lamps are concerned, the single-ended HCl®-TM series with GY22 socket are approved for hot re-ignition. Approval of other double-ended ceramic lamps is in preparation.

4.4 Ignition at low ignition voltage (Penning effect)

Various methods can be used to reduce the voltage necessary to ignite the lamp. One such method uses the so-called Penning effect. When the energy stored in a meta-stable excitation level of the basic gas is larger than the ionization energy of the admixture, volume ionization begins at lower field strengths, resulting in a larger number of charge carriers at the same voltage than in pure gas. Examples for the Penning effect include mercury in argon for metal halide lamps and argon in neon for some discharge lamps.

4.5 Ignition at low ambient temperatures

Most metal halide lamps with wattages ≤ 400 W can be operated at ambient temperatures of -50 °C. The usually evacuated outer bulb and the luminaire ensure that the arc tube is thermally decoupled from the surroundings, so that the normal operating parameters are achieved as far as possible. For HQI® 2000 W NI and 2000 W DI, ignition is only permitted to -20 °C.

In the ignition units, the ferrite core is sensitive to temperature, that is, the rated ignition voltage is lower at lower temperatures. Some ignition unit manufacturers recommend the use of ignition units without cut-out, as the ferrite core in this case is heated up by the losses during failed ignition attempts so that the specified ignition pulse levels are reached again. There are also ignition units with an additional integrated resistor for heating the ignition unit so that these are approved for temperatures down to -50 °C. Here again, it takes a while after switching the ignition unit on until it has heated up enough to reach the specified ignition pulse levels.

For specific applications such as in cold storage houses, semi-parallel ignition units can be used (which permit longer lead lengths) that are fitted in warmer zones outside the luminaires.

4.6 Cable capacitance

The capacitance of the supply cables between lamp and ignition unit depends on various general conditions. These include the size and structure of the cable (diameter, distances and insulation together with number of individual cables, dielectric coefficients of the materials). The capacitance also depends on the grounding and shielding of the cable and where it is fastened, e.g. close to grounded surfaces. Commonly used power cables are not suitable for this purpose, because of their relatively thin PVC-isolation, where the wires lie comparably close together. The capacitance here is about 100 pF/m. Because of the high ignition voltage for discharge lamps the lead wires have thicker insulations and they are normally not placed close to each other. The capacitance of the lead wires will therefore be lower than for the power cable. Capacitances only form limited resistance to high-frequency voltage components of the ignition pulse. The capacitance attenuates the ignition pulse, with resulting ignition pulses possibly not reaching the amplitudes required to ignite the lamp. Certain load capacitances must therefore not be exceeded, depending on the specifications of the ignition unit.

4.7 Start-up behavior of metal halide lamps

After igniting the lamp and heating the discharge, the discharge runs initially only in the start gas. The mercury and the metal halides are still in liquid or solid form on the arc tube wall. The voltage across the discharge is initially still very low. The start gas argon radiates a little in the visible range (weak violet light), which is why the luminous flux in the initial phase is still very low.

Through power consumption in the lamp, first the mercury and then also the metal halides begin to evaporate. The individual filling particles evaporate at different rates, resulting in differing ratios of the particles during runup. The dominance of individual particles in the start-up phase results in the colour phenomena during this period shown in Fig. 22. Only after a few minutes, having reached the steady state, is the required composition achieved, producing the full luminous flux and the required light colour.

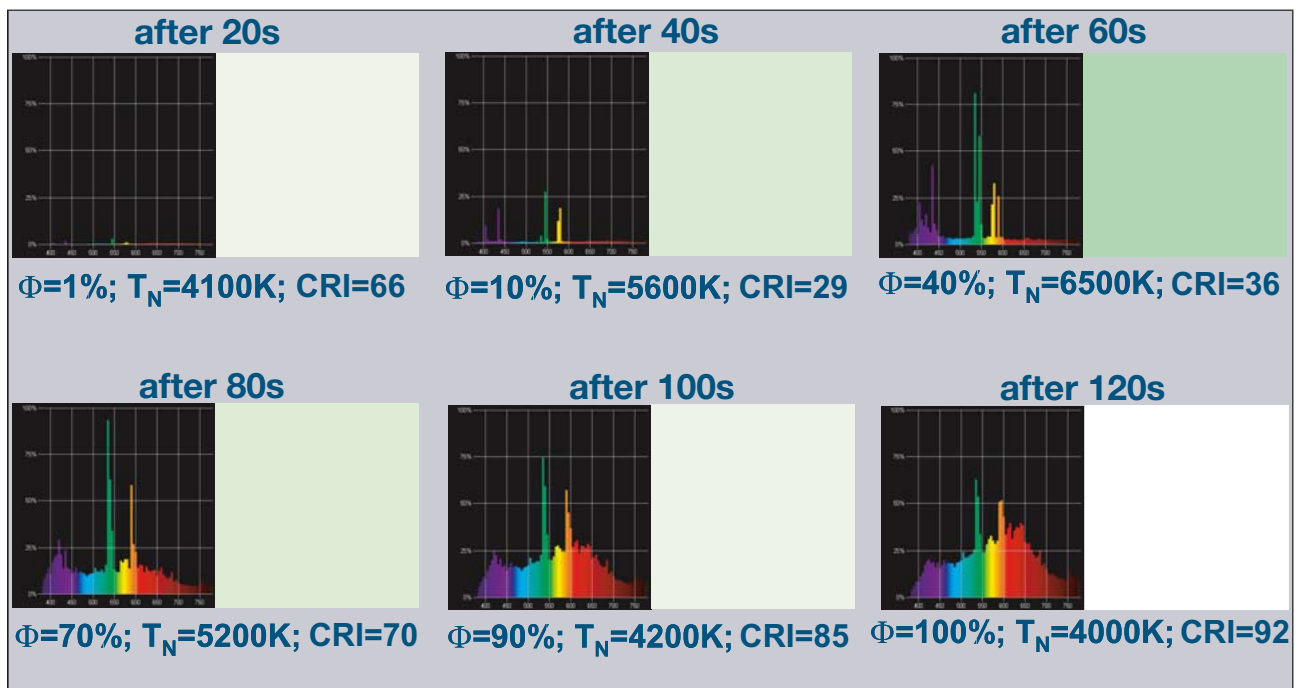

Fig. 22: Course of light parameters of a HCL®-T 150 W/NDL during start-up

The new round ceramic arc tube (POWERBALL®) has a uniform wall thickness without thick ceramic plugs as in the cylindrical ceramic type. The mass is therefore only about half that of the cylindrical version. This means less energy and therefore less time is needed to bring the POWERBALL ceramic arc tube up to operating temperature. The times required to achieve the lit-up status are therefore clearly shorter than in the cylindrical version, as shown in Fig. 23.

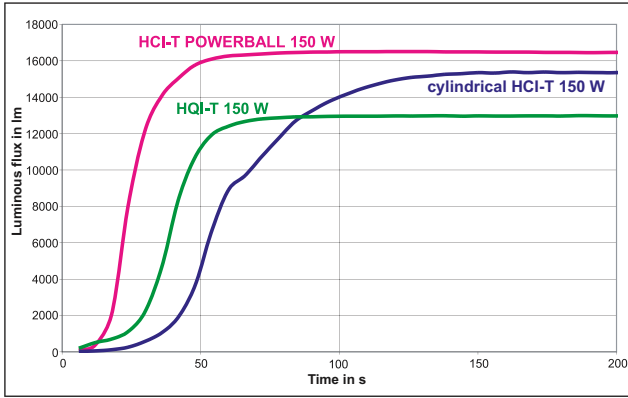

Fig. 23: Start-up behavior of luminous flux in various metal halide lamps operating with an OSRAM electronic ballast

The time it takes to reach a steady state depends on the start-up current and the associated wattage input. If the current is too high, the electrodes will be damaged, causing the walls to blacken. The standard for metal halide lamps (IEC 61667) therefore limits the start-up current to twice the nominal lamp current. With OSRAM POWERTRONIC®, the start-up is faster than with a conventional ballast, as shown in the following Fig. 24.

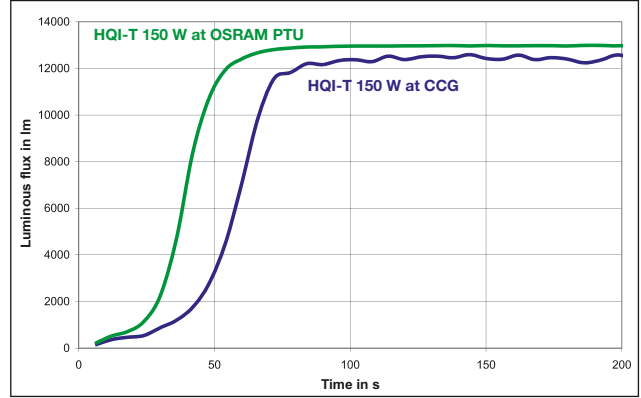

Fig. 24: Start-up behavior of luminous flux of a HQI®-T at various ballasts

5 Reducing the wattage of high intensity discharge lamps

5.1 Introduction

High intensity discharge lamps generate light by exciting mercury and other metals within an arc tube into a plasma generated by the current flow between two electrodes.

Discharge lamps must be operated with a ballast and are rated for a certain lamp wattage. Either conventional chokes or electronic ballasts can be used.

To change the nominal lamp wattage of a lamp, the following general physical conditions are significant for the resulting effects:

- The **electrodes** of discharge lamps are rated for a certain lamp current. If the current is too high, parts of the electrodes melt and evaporate. If the current is too low, the electrode is operated in cold state. This changes the mechanisms for releasing electrons from the electrode with more electrode material being deposited on the tube wall. Deviations in lamp current from the nominal value in both directions can therefore cause **blackening of the arc tube wall with a decline in luminous flux**, together with negative effects on the light colour and possibly also on the service life.
- The partial vapor pressure of the filling particles responsible for generating light depends on the **temperature of the arc tube wall**. A change in the arc tube wall temperature resulting from a change in lamp wattage influences the composition of the filling in the plasma arc and thus the **electrical and photometric properties** of the lamp.
- At higher arc tube wall temperatures, the metals do not recombine with the iodides and the pure metals can migrate into the wall (applies to quartz arc tubes).

Wattage reduction has the following side effects:

- Drop in luminous flux through blackening of the arc tube
- Change in color properties
- Reduction in service life

5.2 Wattage reduction techniques

The following dimming methods are generally known (by conventional means or electronic ballast):

- Reduction in supply voltage
- Phase control: **leading** edge, **trailing** edge
- Increase in choke impedance or decrease in lamp current (amplitude modulation)
- Change in frequency for high-frequency operation

5.2.1 Reducing the supply voltage

A reduction in supply voltage beyond recommended limits (see sections 3.1.2 and 3.1.3) will decrease the lamp wattage. Reducing lamp wattage results in decreased lamp voltage and re-ignition peak voltage, and is generally to a lesser extent than the supply voltage. This reduction in the gap between the re-ignition peak and the supply voltage makes it more probable that the **lamp will go out**. This applies particularly to aged lamps where the lamp voltage and re-ignition voltage have already increased.

Fig. 25 shows, as an example, the behavior of certain lamp types on reducing the supply voltage. Here the ratio of re-ignition voltage to effective supply voltage (U_{LS}/U_S) has been standardized to 1 for 220 V supply voltage. It can be seen that when the supply voltage decreases, this ratio generally assumes values of greater than 1. This also means that the gap between

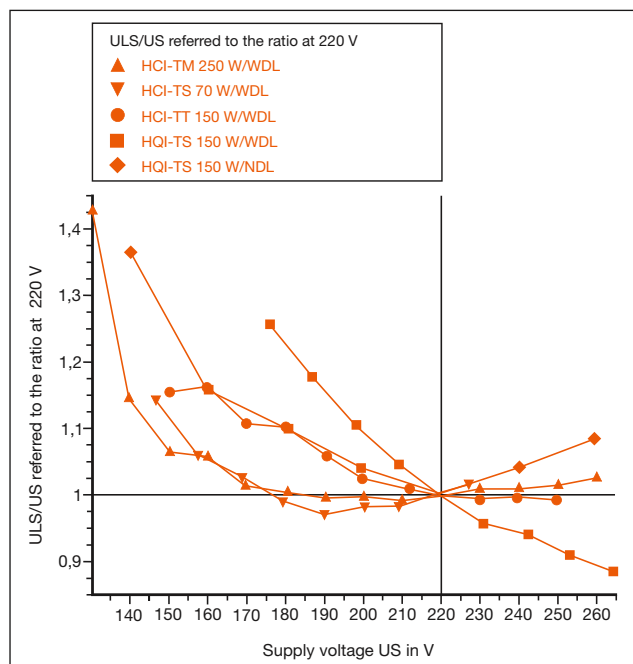

Fig. 25: Relative change in the re-ignition peak (U_{LS}) to supply voltage (U_S) referred to the ratio at 220 V for various metal halide lamps

re-ignition voltage and the current supply voltage decreases. If the re-ignition voltage exceeds the supply voltage, the lamp goes out (see also chapter 6.2.2 “Increase in re-ignition peak”).

This means that POWERBALL HCl® must **not be dimmed by reducing the supply voltage**, as the re-ignition peak can cause earlier extinguishing of the lamp or flicker.

5.2.2 Phase control: leading edge, trailing edge

Fig. 26 and 27 show the decrease in effective supply voltage by phase control with leading edge or trailing edge. There are also variations in which the supply voltage is reduced in the middle and not before or after the zero crossing. In other versions, the supply voltage in the leading edge phase is only decreased and not reduced to zero.

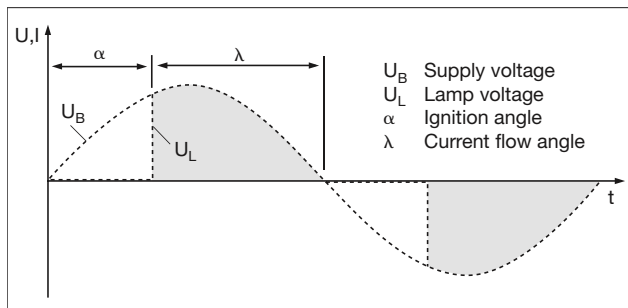

Fig. 26: Principle of phase control with leading edge (idealized diagram)

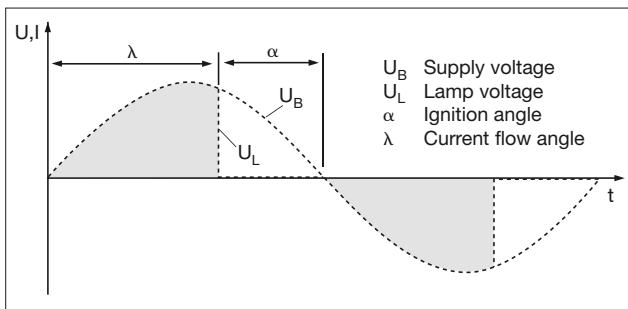

Fig. 27: Principle of phase control with trailing edge (idealized diagram)

For the **phase control with leading edge**, the resulting intervals with no current result in a greater cooling down of plasma end electrodes, thus increasing the re-ignition peak, causing the lamp to go off earlier.

For the **phase control with trailing edge** or other methods where supply voltage is temporarily switched off or reduced, suitable means are required to provide an uninterrupted, “smooth” lamp current to prevent the lamp from flickering and going off.

Increased blackening and therefore a drop in luminous flux must be expected in all versions compared to full-load operation.

5.2.3 Increasing choke impedance or decreasing lamp current

Increasing choke impedance reduces the current through the lamp. The supply voltage remains the same so that the voltage is still high enough to re-ignite the lamp. The flatter zero crossing of the current can however be expected to cause greater cooling down of plasma and electrodes, with greater blackening as a result of the processes at the electrode during re-ignition. The blackening therefore causes a greater drop in luminous flux compared to full-load operation.

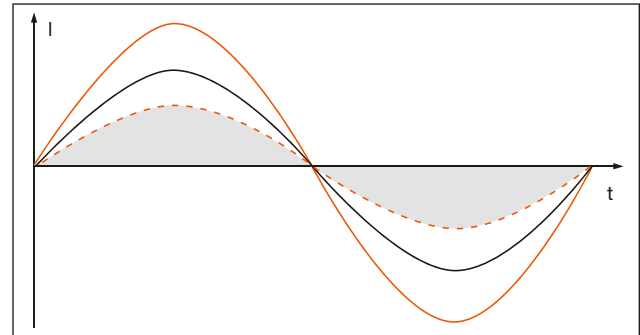

Fig. 28: Amplitude modulation e.g. by choke change-over

The least disadvantages are to be expected by reducing current in rectangular mode. The steep zero crossings mean that lower re-ignition peaks and less blackening from sputtering can be expected.

If a switchover to other chokes is used for dimming lamps with a wattage ≥ 400 W, they must be left to burn at 100% for at least 1 hour.

5.2.4 Change in frequency for high-frequency mode

A change in wattage when using an inductive ballast can also be achieved by varying the frequency of the power supply, as the inductive resistance of the choke depends on frequency. The change in choke impedance at low frequencies has been dealt with in the preceding chapter 5.2.3.

If the change in impedance is caused by changing the frequency in radiofrequency operation, in discharge lamps the possible occurrence of acoustic resonances has to be considered. Resonance in the discharge tube can cause the plasma to start to oscillate depending on the arc tube geometry and plasma temperature. This can cause the lamp to flicker or go off, and in extreme cases, destruction of the lamp should the arc attach to the arc tube wall due to severe resonance. This is why a currently proposed standard for electronic operation of metal halide lamps limits the amount of high-frequency oscillations.

It is difficult to find reliably resonance-free operating windows, for various reasons: the resonance frequencies change during the start-up and also dur-

ing the course of the service life. Lamps of differing geometries and filling also show different resonance frequencies. A reduction in wattage also changes the resonance frequencies due to the change in plasma temperature.

5.3 Recommendations for reducing the wattage in discharge lamps

5.3.1 Metal halide lamps:

Operation of OSRAM POWERSTAR HCl[®] (cylindrical burner) and OSRAM HQI[®] lamps with reduced power is not permitted as this can cause considerable colour deviations, much poorer luminous flux maintenance and shorter service lives

Basically it is possible to dim POWERBALL HCl[®].

While the higher thermal load capacity of the round ceramic arc tube permits an improved dimming behaviour in terms of luminous efficacy and colour rendering compared to metal halide lamps with quartz arc tube or with the normal cylindrical ceramic tube, dimming still causes a shift in the chromaticity coordinate. Dimmed lamps show a greater drop in light output and wider colour spread throughout the service life.

It is important to avoid these effects for interior lighting. They are more apparent when operated on conventional control gear than on electronic control gear. OSRAM therefore recommends not to reduce power with currently available lamps on conventional control gear or for indoor lighting.

The type of dimming has a great impact on the results. It is recommended to use only adjustable Electronic ballasts with squarewave operation and to completely avoid dimming via reducing the supply voltage or leading-edge or trailing-edge phase dimmers. It is not possible to guarantee that dimmed lamps will be able to meet the product properties.

In any case, the lamp should run for at least 15 minutes with 100% wattage after being switching on so that the lamp can light up correctly.

A warranty regarding lifetime can only be given when approved POWERBALL HCl[®] units (cf. online catalogue) on the POWERTRONIC[®] PTo are dimmed.

Operation of POWERBALL HCl[®] on the POWERTRONIC[®] PTo:

The combination of POWERBALL HCl[®] and POWERTRONIC[®] PTo allows energy-saving operation everywhere where optimised colour rendering is not important, for example outdoor lighting.

The PTo with squarewave operation and optimised ignition runs the POWERBALL HCl[®] lamps ideally down to 60% of the lamp output (rated value). No significant negative effects arise even when the output is reduced to 85% of the rated output.

Even when operated at between 85% and 60% of the rated output, this does not negatively effect the failure rate. However, increasingly the lamps have a slightly green touch and the colours may deviate from each other (colour spread).

The luminous flux drops slightly more throughout the service life in dimming mode than when operated at 100% on the PTo. This effect can be reduced if the lamps are operated via a combination of dimming and 100% operation.

Dimming causes a reduction in light output and colour change.

Squarewave operation is recommended for dimming.

For outdoor lighting: optimised operation of the approved POWERBALL HCl[®] on the POWERTRONIC[®] PTo.

There is no warranty for dimmed POWERBALL HCl[®]. A warranty regarding lifetime can only be given when approved POWERBALL HCl[®] units (cf. online catalogue) are dimmed on the POWERTRONIC[®] PTo.

5.3.2 Dimming of other discharge lamps

High pressure mercury lamps:

These lamps can be dimmed to 50% of the rated wattage, whereby they must be started up with 100% wattage. Dimming is possible by voltage reduction, phase control and amplitude modulation.

High pressure sodium lamps:

It is possible and allowed to reduce the power of all VIALOX[®] NAV[®] down to 50% of the lamps rated values without impact on the service life

- via step switching by changing to inductive control gear with the next lower rating or
- via step switching with additional inductance,

whereby in both cases electronic power switches must be used.

When reducing the power, ensure that the lamps are started and operated at their rated values for approx. 10 minutes before dimming.

It is not permitted to reduce the power by leading edge phase control or reducing the mains voltage.

OSRAM recommends the electronic ballast POWERTRONIC[®] PTo for dimming operation.

6 Lamp service life, aging and failure behavior

6.1 Lamp service life and aging behavior

All lamp-specific electrical and photometric data are ascertained after operating for 100 hours under laboratory conditions using reference ballasts (according to IEC). The service life data are determined under controlled laboratory conditions with a switching rhythm of 11 h on/1 h off. In practice, noticeable deviations can occur due to deviating supply voltage, ambient temperature and other general conditions. For metal halide lamps, there can be individual differences in colour from lamp to lamp, caused by external influences such as supply voltage, control gear, burning position and luminaire design.

Unless stated otherwise, the specifications apply to TS types for horizontal burning position and to T and E types up to 250 W for base up burning position. For lamps > 400 W, the horizontal burning position applies for the T-lamp. For lamps with 400 W, the burning position depends on the type (as stated in the catalogue). Should deviating burning positions be used in practice, this could cause changes in luminous flux, colour temperature and service life. The POWERBALL HCl® with its round arc tube is less critical than conventional cylindrical ceramic tubes.

The luminous flux is generally independent of the ambient temperature itself outside the luminaire. However, too high ambient temperatures can cause increased arc tube blackening in the long run. Also, special ignition units are required for lower ambient temperatures down to approx. – 50 °C. HQI®-2000 W lamps with integrated auxiliary discharge are only permitted to – 20 °C.

For measurement of the electrical, photometrical and colour characteristics, HQI®-TS and HCl®-TS lamps shall be operated within a luminaire simulator. Details on luminaire simulator (Quartz tubes around the lamp) for determining the lamp data for HQI®-TS and HCl®-TS can be found in IEC 61167, Annex B.2.

The mean service life stated in the documents (B50 value) is the burning time within which maximum half of the lamps can have failed, i.e. the survival rate at this point in time is at least 50%. This is a value normally indicated by all lamp manufacturers. Apart from the B50 value, it is also common practice to indicate the times e.g. at which 10% or 3% of the lamps failed (B10 or B3).

Mean service life (B50):
max. half the lamps have failed.

Economic life:
on account of the decrease in luminous flux and the increasing failure rate, the illumination level of the installation has fallen below a required value.

The economic life is obtained by including the decrease in luminous flux over the service life in the calculation. Multiplying the survival rate by the maintenance of the luminous flux provides the decline in luminous flux of the installation. These factors are considered when preparing a maintenance schedule according to EN12464 (see also 7.5 *Maintenance of lighting systems with metal halide lamps*).

Data on lamp survival behavior and luminous flux behavior can be found in the corresponding Technical Information.

One main reason for the reduction in luminous flux is blackening of the arc tube by electrode material which has settled on the tube wall throughout the service life. Frequent switching, overload operation, use in confined luminaires or high ambient temperatures can add to this blackening process and thus clearly reduce the service life. Operation at reduced wattage also causes increased tube blackening, as explained in chapter 5 *“Reducing the wattage of high-intensity discharge lamps”*.

6.2 Storage of metal halide lamps

Incorrectly stored lamps (e.g. damp and warm) may suffer corrosion on the contacts after a while; this oxidation must be completely removed before the lamps are used. In unfavourable conditions, this may even result in ignition problems. Lamps with filler material may lose this filler material if stored incorrectly and the socket contacts may then become exposed. There is a risk of arc-overs during the ignition process or the risk of touching live parts.

6.3 Failure mechanisms of metal halide lamps

The following failure mechanisms are possible for metal halide lamps and the probability increases as the lamp gets older.

- Leaking arc tube
- Increase in re-ignition peak, finally the lamp goes out
- Broken leads
- Leaking outer bulb
- Ignition failure
- Breakage or wear of the electrodes in the arc tube
- Scaling of the base contacts by arcing in the socket
- Bursting of the lamp

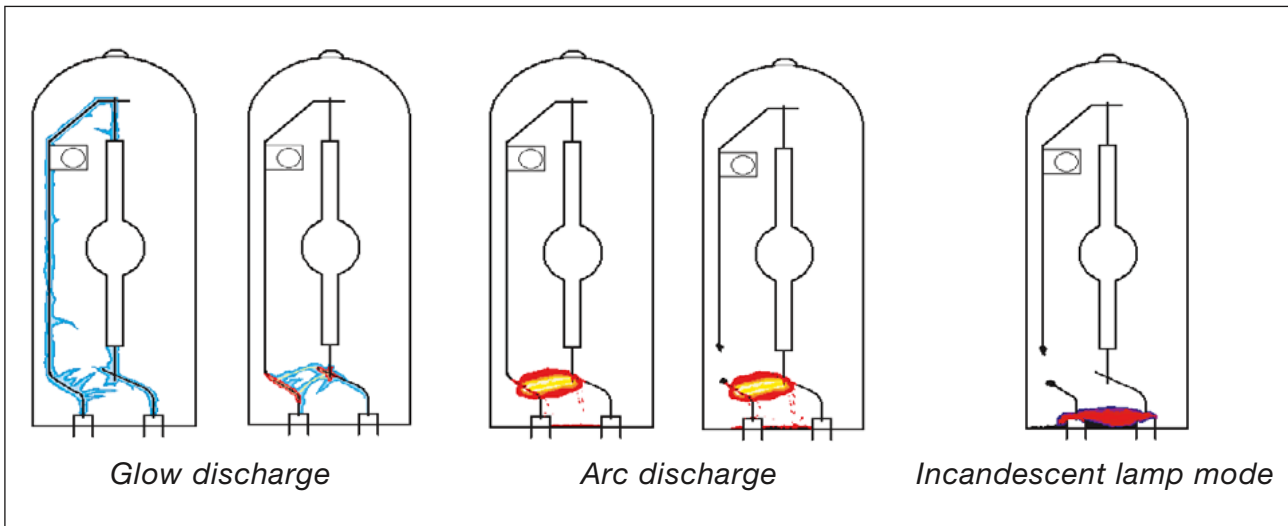

Fig. 29: Various states of outer bulb discharge

6.3.1 Leaking arc tube

High temperatures and pressures in the arc tube, the aggressive chemical substances in the tube and the thermal cycling of a lamp place extreme strains on the arc tube. This can cause the tube to leak, allowing starting gas and filling particles to enter the outer bulb. Depending on the size of the leak, this effect is usually a gradual process. It is initially noticed by a considerable change in the light colour. Increasing leaks of starting gas into the outer bulb can result in the discharge process moving from the arc tube to outer bulb discharge.

- For lamps with evacuated outer bulb, various abnormal discharge states can occur, depending on tube filling pressure and outer bulb volume.
- For lamps with gas-filled outer bulb, usually lamps ≥ 400 W, glow discharge and incandescent mode do not occur. Particularly in lamps operating with ignition units, the described faults result in a direct arc discharge. In extreme causes, this can cause the lamp to burst.

In the case of **glow discharge**, the voltage across the lamp is high but only very low current. Sputtering causes material to be deposited on the outer bulb. It is possible for glow discharge to precede arc discharge. The temperatures in the pinched area are lower than in normal operation.

In the case of **arc discharge**, the voltage across the lamp is low and the current is limited by the choke. The attachment of the arc onto the leads in the outer bulb can cause these to melt. The high temperatures cause the material of the leads to evaporate and then settle on the outer bulb. The hot arc near the pinching area can result in high temperatures (in extreme cases they can exceed 800 °C). At the contact between socket and lamp holder and at the electrical contact, the temperatures are naturally much lower. Here in extreme cases 300 °C were measured at the contact between lamp

and lamp holder and 250 °C at the electrical contact of the lamp pin to the lamp holder. The electrical contact is also relevant for the Temperature Code of the socket (see also chapter 7.3 lamp holder).

If metallic coatings in the pinching area form through material deposition from the leads so that they form a continuous conductive layer between the leads, then the result is the so-called **incandescent mode**. The metal coating offers sufficient resistance that power is consumed and the coating begins to glow. It is hereby possible that electrical values similar to normal operation are reached, which would make it impossible for an electronic ballast for example to detect this abnormal situation. This also causes high temperatures in the pinching area.

Glow and arc discharges can be detected by current and voltage values deviating from the normal levels, so that an electronic ballast with a corresponding automatic cut-out feature can switch off such lamps. In addition, the luminaire design must use components resilient to high thermal loads so that the possibly high temperatures will not lead to harmful situations for the operator.

6.3.2 Increase in re-ignition peak

The re-ignition peak is a peak in the lamp voltage after the zero crossing of current and voltage. For sinusoidal lamp current, the current decreases gradually before the zero crossing. As the plasma is heated by the current flow, a decrease in current causes the plasma to cool down and reduces its conductivity. After the zero crossing, the cooled plasma can initially no longer conduct the current through the lamp. As the current does not rise through the lamp, an increasing amount of supply voltage falls across the lamp. The rise in voltage causes the ionization of the plasma and therefore the current to increase again, meaning the plasma is reignited, hence the name “re-ignition peak”. If the re-ignition peak exceeds the level that can be provided by the supply voltage, the lamp goes out.

This is one of the advantages of the rectangular electronic ballast. As the zero crossing for current is very steep, the events of limited current availability are very short and the plasma has little chance to cool down.

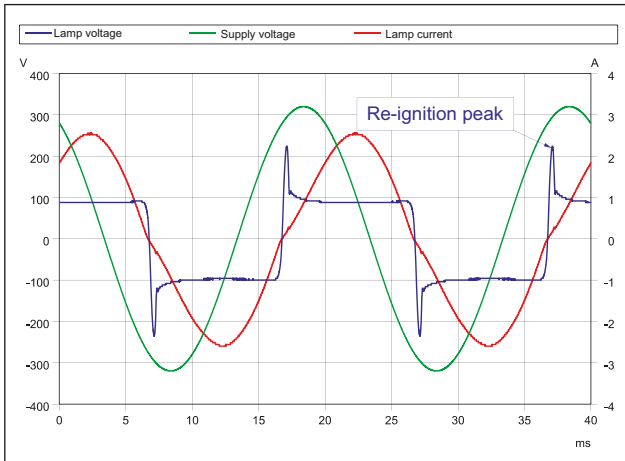

Fig. 30: Re-ignition peak, supply voltage and lamp current

The lamp voltage and the re-ignition peak increase with progressing lamp age; in addition, this parameter also depends on the ambient temperature and increases while the lamp is heating up. This results in what is known as cycling, where the lamp periodically goes off and on again. The re-ignition voltage increases while the lamp is heating up and continues to increase until the luminaire is completely heated through. This is why it can happen that the lamp does not go off until after several or even many minutes of burning time.

Fig. 31 shows a lamp with high re-ignition peak. After the zero crossing, the current barely starts to flow. This is why the voltage loss across the choke is low and nearly the entire voltage supply falls across the lamp, with lamp voltage following supply voltage. The current flow decreases even further from period to period, so that conductivity continues to fall; in the end, the voltage required to re-ignite the plasma is higher than the supply voltage → the lamp stays off after the zero crossing.

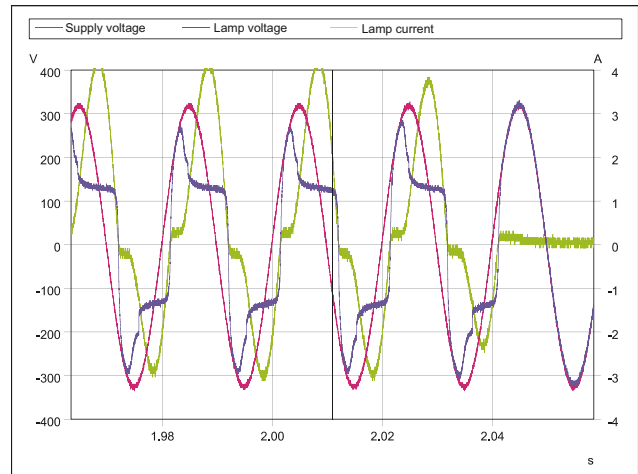

Fig. 31: A lamp goes out because the re-ignition peak is too high

A decline in the supply voltage can also cause the lamp to go out. It is only when the lamp has cooled down sufficiently that re-ignition is possible with the normal ignition units. After “cycling” for a long time, it is possible that the lamp will not ignite at all.

This fault is not critical if the ignition unit does not suffer from the frequent ignition attempts.

6.3.3 Broken lead or broken weld

This can be caused by material fatigue or extreme mechanical load. Normally this is a non-critical fault; in very rare cases, a loose contact can cause high induced voltages.

Lamps with gas-filled outer bulb for supply voltages of 400 V can form an arc when a lead is broken or a weld comes loose. Due to the current-limiting choke, this arc can persist for a longer period of time and cause the lamp to burst. Such arcing occurs both in lamps with an ignition unit and lamps with auxiliary starter electrode (lamps for ignition at supply voltage with a wattage of 2000 W).

6.3.4 Leaking outer bulb

Mechanical impacts can cause the outer bulb to leak so that air penetrates. Given the high temperatures, leads oxidize when oxygen is present, causing an open in the circuit. This is a non-critical fault; the lamp no longer ignites. Ignition units without cut-out can, however, fail prematurely due to permanently generating ignition pulses.

6.3.5 Lamps that do not ignite

This can result from open electrical connections within the lamp or extreme aging and is actually a non-critical fault. Ignition units without cut-out can, however, fail prematurely due to permanently generating ignition pulses.

6.3.6 Breakage or differing wear of the electrodes

Breakage of an electrode or differing wear in the electrodes with choke operation can cause a flow of asymmetric current with DC components, which can result in the choke overheating. This effect of asymmetrical conductivity is dealt with in greater detail below.

A broken electrode in a ceramic lamp can cause leaks in the arc tube as a result of overheating capillaries, with the effects described above. In rare cases, a discharge attachment near the arc tube wall in ceramic lamps can cause the arc tube to burst.

A broken electrode in a lamp with quartz arc tube can, after a longer period of time, cause the arc tube wall to bulge and possibly leak or burst, if the discharge still persists.

6.3.7 Scaling of the base / socket

Particularly in the case of old ignition units without automatic cut-out and aged lamps or soiled contacts, high transition resistances can cause oxidation and thus overheating of the contacts. When ignition pulses persist for a longer period of time, if lamps have gone out because the re-ignition peak is too high or if the lamp has not ignited, it is possible for arc-over to occur in the socket. If scaling has occurred, the socket must be replaced as well as the lamp.

Vibrations can cause the lamp to become loose with the possibility of arc-overs and scaling caused by the resulting poor contact. In these cases the usage of a lamp holder with retention device is recommended, as described in the standard IEC 60238 "Edison screw holders", section 2.23 "Lamp holder with retention device". The test conditions are described in section 12.14.

Suspending the luminaire on a chain attenuates vibrations compared to suspending it on a rope.

6.3.8 Bursting of the lamp

It is generally possible for the arc tubes of metal halide lamps to burst. This is very rare for ceramic metal halide lamps; the probability is greater in lamps with a very old quartz arc tubes. With progressing age, the quartz crystallization increases, making it brittle. However, the lamps normally fail by going out.

During operation, the arc tube is under great pressure. When the arc tube bursts, fragments can fly at great speed, destroying the outer bulb when they hit it.

When the outer bulb is broken after the tube has burst, very hot fragments of the arc tube come into contact with the luminaire.

OSRAM therefore strictly differentiates between lamps for open and closed luminaires. Lamps for open luminaires have a mechanical safeguard around the arc tube to ensure that all fragments remain intact within the outer bulb should the arc tube burst. Compliance with this requirement is ensured through inhouse tests at OSRAM, which are much more stringent than in actual operation and in some published standards, for example, ANSI Standards.

This is the corresponding pictogram for lamps of this kind as per IEC 62035.



As it is generally not possible to rule out the possibility of the lamp bursting for all other lamps, metal halide lamps must be operated in closed luminaires, which are designed to contain all hot fragments of the lamp in the case of it bursting. The corresponding pictogram for lamp and luminaire according to IEC 62035 is shown on the right.



Silicate glass panes are recommended as a cover screen. When plastic screens are used, it is important to ensure that the hot parts of the lamp will not melt or set fire to the screen should the lamp burst.

The cover screen must be both resistant to temperature change and break-proof.

6.3.9 Rectifying effect

High intensity discharge lamps can assume an asymmetrical mode (rectifying effect). There are various possible causes:

- Differently heated electrodes:
This is typical when the lamp starts, but is normally only short-lived. The DC component sends the choke into saturated state, the magnetic resistance decreases and current is limited to a lesser extent, shown as an example in Fig. 32. This effect is described in the standards as „in-rush current“ (IEC 61167).
- Malfunction of one of the electrodes:
This can be caused by differently worn electrodes, or in rare cases by a broken electrode. The result is longer asymmetrical lamp current, or if an electrode has broken off, a permanently asymmetrical lamp current.

The effects are similar to rectifying effect at the start, but the longer persistence can cause overheating of the choke and ignition unit.

- Discharge in the outer bulb:
As the leads are not geometrically the same, the discharge generated between them can be asymmetrical, with the effects described above.

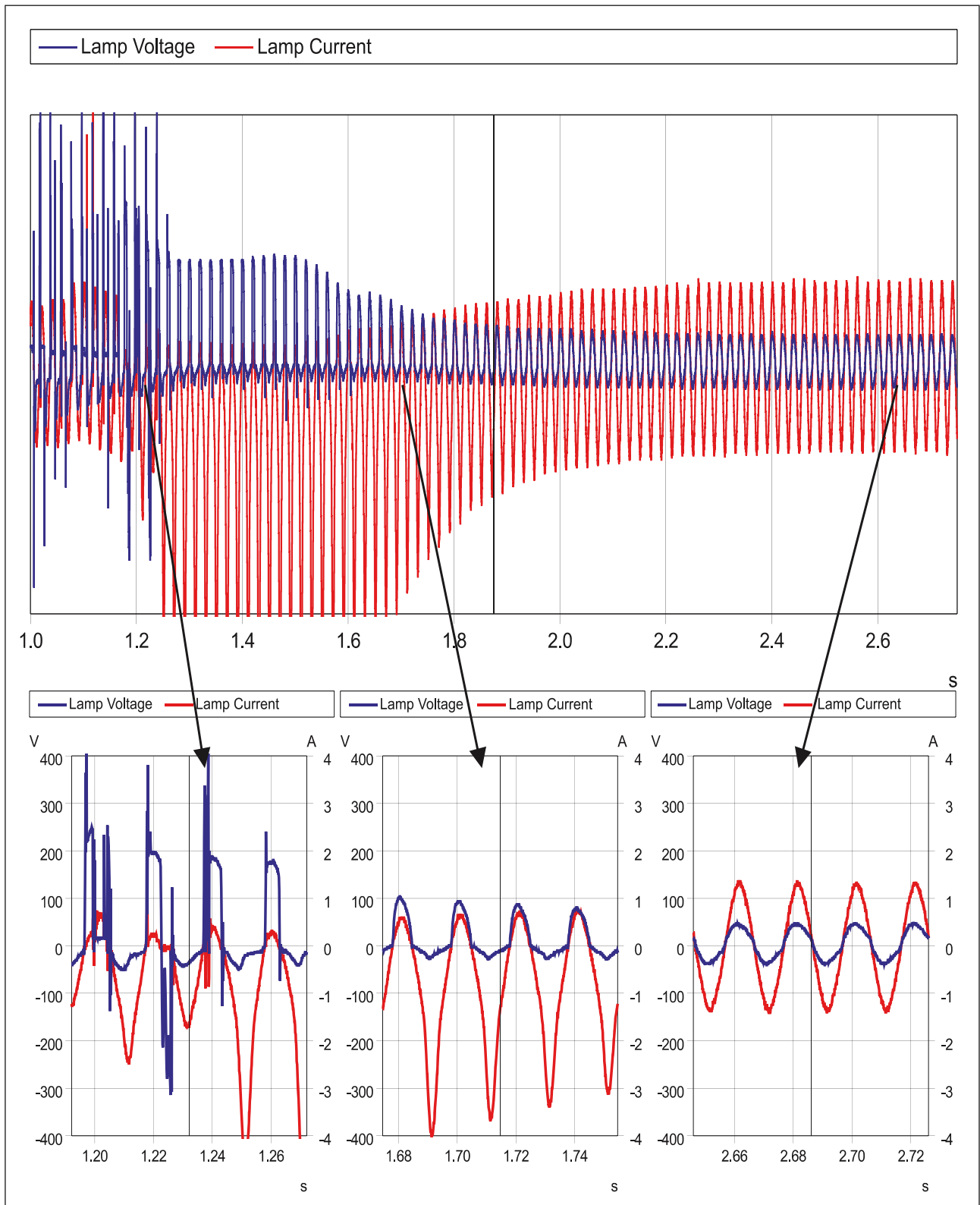

Fig. 32: Asymmetrical conductivity with lamp current and lamp voltage during a normal lamp start. This is only a transient effect which causes no harm.

Rectifying effect causes a high DC current component. As a result, the choke goes into saturated state with a marked decrease in choke impedance. In extreme cases, the lamp current is only limited by the choke's ohmic resistance.

Permanently excessive current causes a dramatic increase in the temperature of the choke windings until the insulation is destroyed and short circuits occur between the choke windings.

These phenomena can occur with metal halide lamps (see warning in IEC 61167) so that the standards have stipulated safety measures for luminaires (see IEC 60598-1 Paragraph 12.5.1). Similar regulations exist for high intensity sodium vapor lamps in the IEC 60662 standard.

A safety measure in the circuit such as a thermal switch or a thermal fuse, integrated into the magnetic ballast, protects the circuit from such damage.

In accordance with a declaration issued by lamp manufacturers in reaction to standard EN 62035, published by the LIF (Lighting Industry Federation Ltd) in Technical Statement No. 30, and by the ZVEI in the "Lamp manufacturers statement regarding EN 62035", certain lamps do not require any safety measures to prevent asymmetrical conductivity. As far as OSRAM's metal halide lamps are concerned, this refers to lamps with wattage levels of 1000 W and more.

Although asymmetrical conductivity is generally possible in lamps with wattages ≥ 1000 W both during the start and in steady state, the dimensions of the arc tube and lamp components means that the tendency to asymmetrical conductivity is far less than with smaller wattage levels, and is weak enough in steady state that no safety measures against asymmetrical conductivity are required.

OSRAM PTi is not affected by asymmetrical conductivity, as current and voltage are monitored and controlled, which is why it is recommended for the operation of discharge lamps.

6.3.10 Conclusions

- Safe operation of metal halide lamps depends on the use of luminaire parts (lamp holder, leads etc.) which can withstand the high temperatures that can possibly occur in the case of outer bulb discharge.
- Apart from burst-protected lamps for operation in open luminaires, all lamps must be operated in closed luminaires.
- All metal halide lamps with small wattage must be equipped with a safeguard to protect the lamp from the effects of asymmetrical conductivity (e.g. chokes with thermal protection).
- It is advisable to use ignition units with time cut-out.
- The use of electronic ballasts is beneficial if the electronic ballast has a corresponding cut-out mechanism.

It is wise not to operate metal halide lamps right up to the end of their natural service life, but to replace them at the end of the economic life. This is appropriate because the luminous flux decreases noticeably on exceeding the economic life, and the probability of undesirable effects increases at the end of the service life.

Lamps should be replaced before reaching the economic life if

- the light colour of the lamp changes noticeably,
- the luminous flux decreases considerably,
- the lamp will not ignite,
- the lamp goes on and off intermittently ("cycling").

On complying with all safety measures, metal halide lamps are safe to operate and provide a brilliant, efficient light.

7 Luminaire design and planning of lighting systems

7.1 Measuring temperatures, ambient temperature

7.1.1 General physical conditions for temperature limits for outer bulbs and pinches in metal halide lamps

When the limit values for pinch temperature or outer bulb temperature for hard and soft glass are exceeded, the following can be expected:

- the foil oxidizes
- the evacuated outer tube collapses and the gas-filled outer tube blows out when the glass turns soft
- the cement in screw-base lamps crumbles

Although quartz glass can withstand far higher temperatures than the stated limit values, it is possible for the arc tube to overheat when the stated limit values for the outer bulb are exceeded, with the following effects:

- change in colour properties
- leaking arc tube
- blackening of the arc tube and deterioration in luminous flux maintenance

The outer bulb temperature is only an **indirect** indicator for arc tube load! Outer bulb and arc tube are coupled by radiation and to a small extent by thermal conduction via the leads.

While it is important to limit the outer bulb temperature, it is worthy to note that an inadequately designed reflector can still cause the arc tube to overheat without any major change in the outer bulb temperature (see also chapter 7.9 "Optical design of reflectors").

One indication that the design of a luminaire is insufficient comes from comparing the lamp voltage measured when burning freely outside the luminaire, and inside the luminaire after being left long enough to stabilize. The increased lamp voltage measured in lamps ≤ 400 W in the luminaire should not exceed 5 V.

There is no notable difference in the lamp voltage inside the luminaire for lamps with wattage input ≥ 1000 W, outer bulb and free-burning operation. But soiling of the outer bulb caused by evaporation from luminaire components can cause the lamp voltage over its service life to increase more than in free-burning operation. This increase depends on the level of surface soiling in the lamp and can therefore not be put in figures. To avoid this effect, it is recommended to use temperature- and UV-resistant materials in the luminaire.

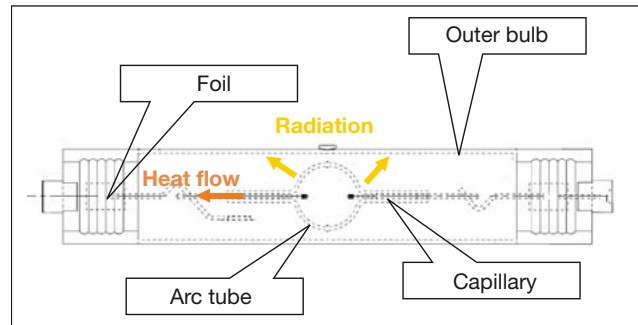

Fig. 33: Diagram to show thermal coupling of arc tube and outer bulb

7.1.2 2 Measurement with thermocouple

Measurement with thermocouple is a simple, practical method of obtaining measured values.

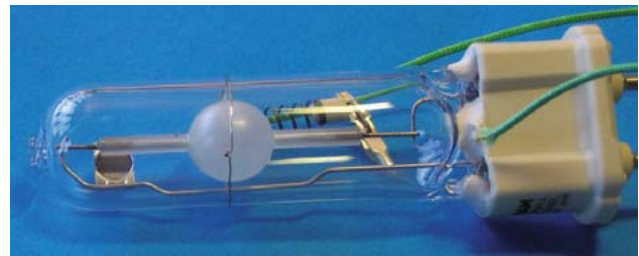

Fig. 34: Affixing the thermocouples to the outer bulb and the lamp base



Fig. 35: Clamping the thermocouple on the outer bulb using a spring element

Please adhere to the following to properly measure with a thermocouple:

- Good contact with the surface being measured
- Low heat dissipation from the connection point and therefore
 - thermocouple wire with a small diameter
 - thermocouple wire parallel to the surface being measured

- When measuring the outer bulb temperature, corresponding evaluation must consider the radiation (cooling-down curve)

The radiation of the arc tube heats up the thermocouple on the outer bulb above the temperature of the quartz glass on which it is positioned. Because of the low thermal capacity, the thermocouple cools down quickly to the temperature of the quartz glass, after switching off the lamp, and then cools down slowly with the quartz, as shown in Fig. 36 and Fig. 37. The flat part of the cooling curve can be extrapolated back to the switch-off point to ascertain the temperature of the outer bulb during operation.

The measurement must be made under worst case conditions, i.e. for the pinch temperature: base up burning position, for the outer bulb temperature: horizontal burning position (if permitted).

Compliance with the outer bulb temperature is not always sufficient to design a “good” luminaire.

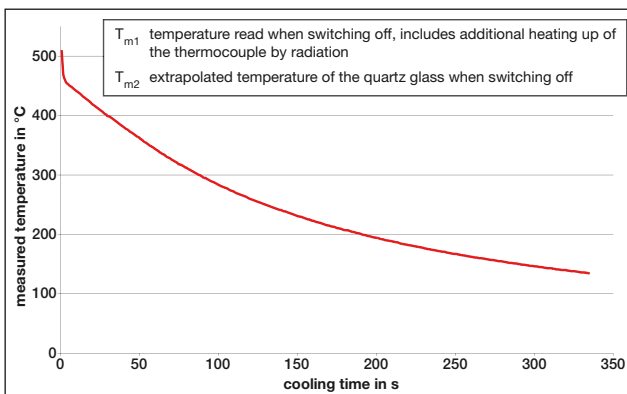

Fig. 36: Cooling curve for HCL-T 150 W/830 PB in closed luminaire, lamp wattage 180 W

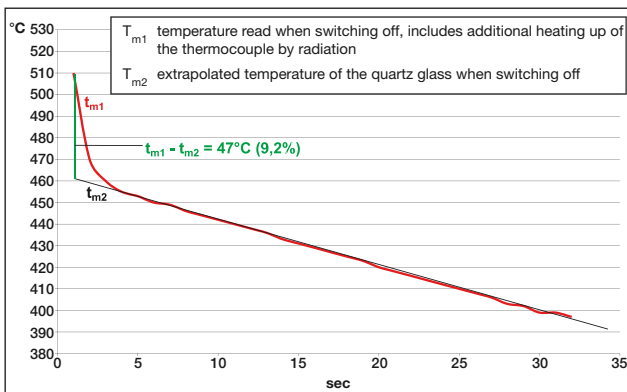

Fig. 37: Enlarged detail of figure 36

7.1.3 Measuring points for thermocouples in different lamp types

The specific limit values are stated in the Technical Information.

The measured values are to be ascertained under the worst case conditions.

Both supply voltage and choke impedance influence lamp wattage. A lower choke impedance and higher supply voltage each cause an increase in lamp wattage. As the limit temperatures also increase with increasing lamp wattage, the worst case is to be ascertained at the maximum possible lamp wattage. To cover all possible parameters such as choke impedance, spread of lamp wattage and supply voltage tolerance. Lamp wattage should be set to approximately 20% above the normal wattage for measurement purposes.

The operating temperatures of a lamp differ according to the burning position. The worst case operation is the base up burning position for pinch or base edge temperature measurements and the horizontal burning position for the outer bulb temperature measurement, insofar as this is possible with the permitted burning positions.

Temperature measurement lamps prepared with thermocouples are available from OSRAM on request for a fee.

7.1.3.1 HCl®-TC G8.5

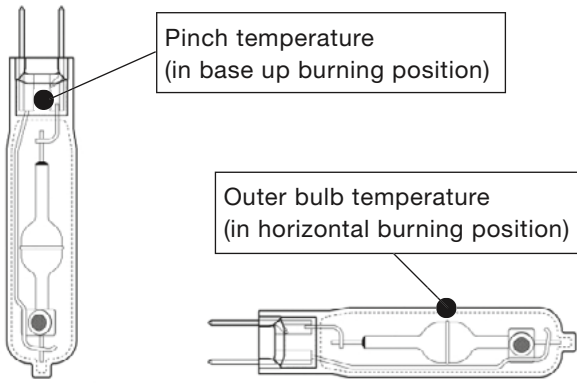

7.1.3.4 HCl®-E and E/P / HQI® E27 and E40

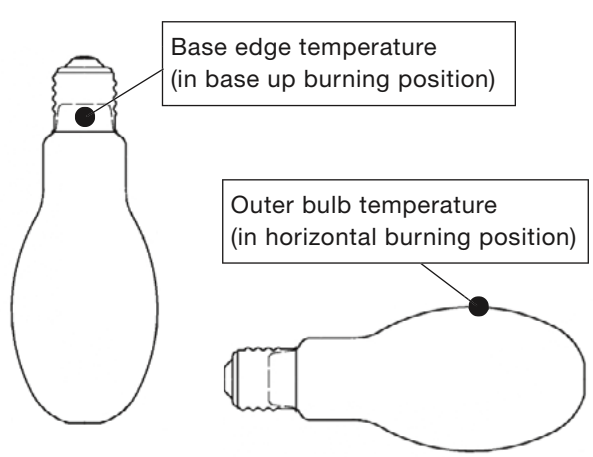

7.1.3.2 HCl®-T / HQI®-T G12
(similar for the HCl®-TM and HQI®-TM G22)

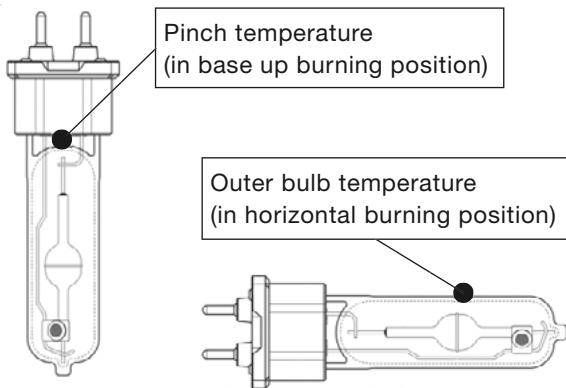

7.1.3.5 HCl®-T and TT / HQI®-T E27 and E40

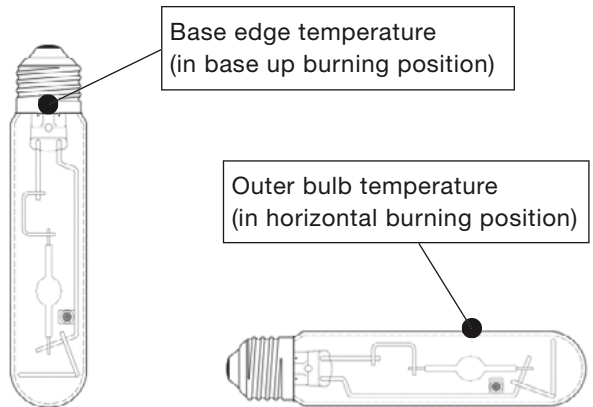

7.1.3.3 HCl®-TF, GU 6.5

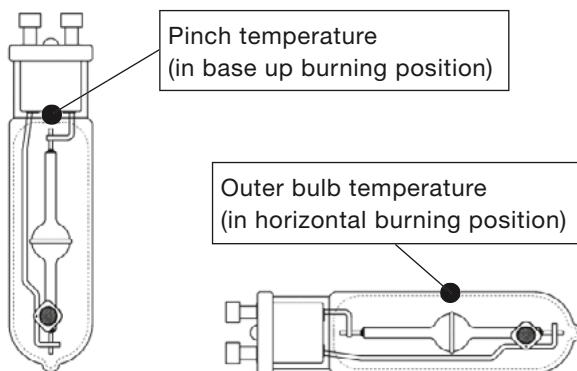

7.1.3.6 HCl®-TX/P

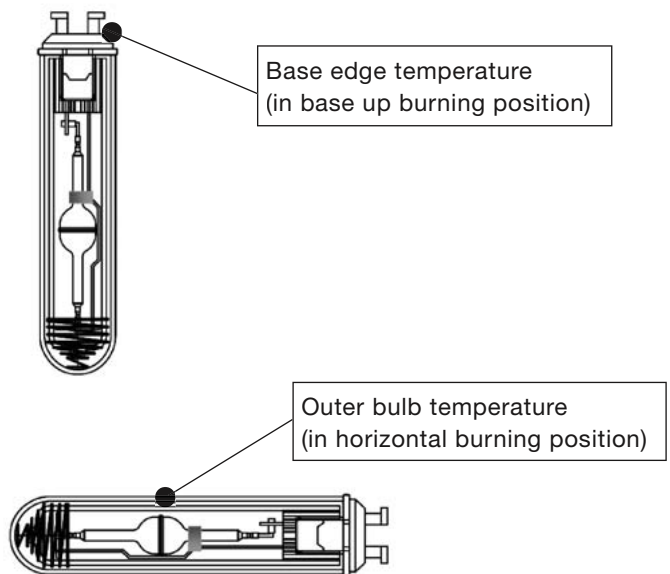

7.1.3.7 HCl®-TS, RX7s, RX7s-24 and HQI®-TS Fc2

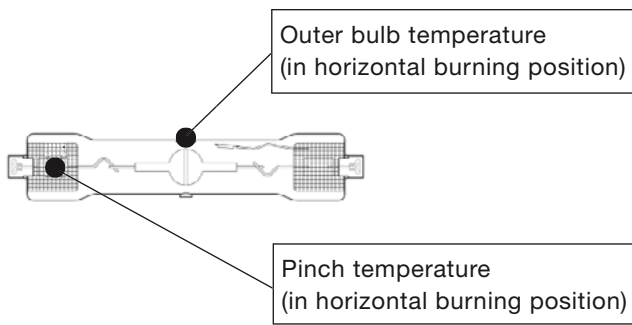

7.1.3.10 HQI®-T, $\geq 1000\text{ W}$

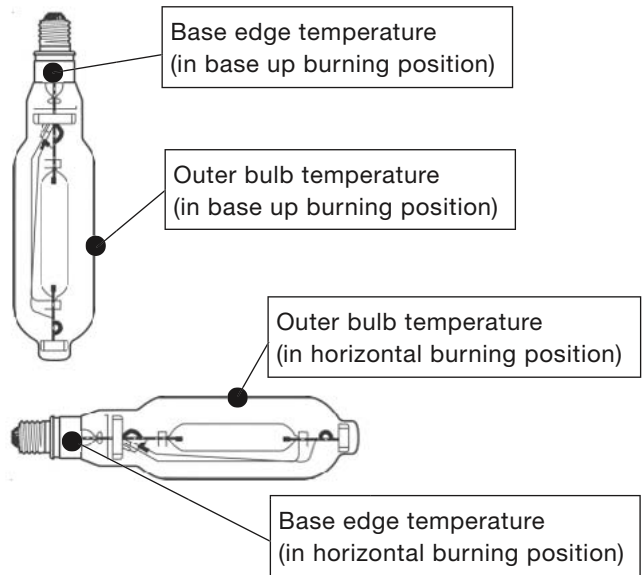

7.1.3.8 HCl®-PAR E27

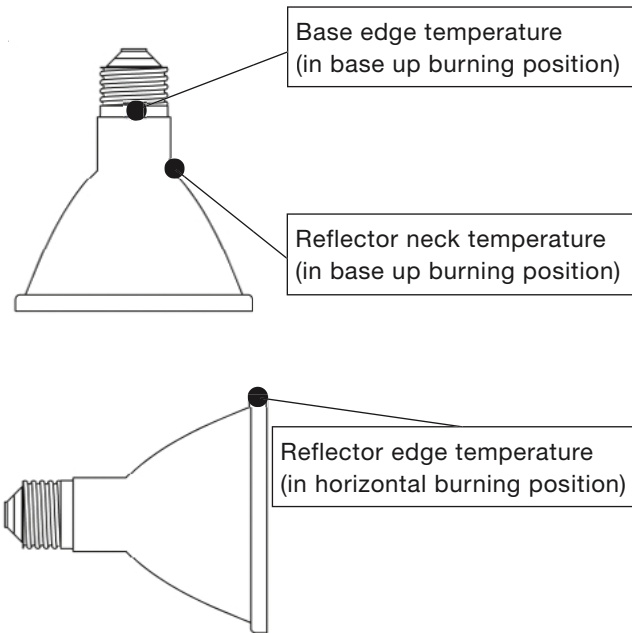

7.1.3.11 HQI®-TS Excellence

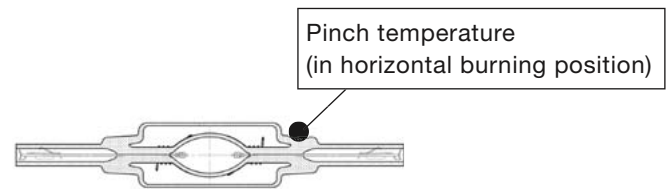

7.1.3.9 HQI®-TS long arc and short arc $\geq 1000\text{ W}$

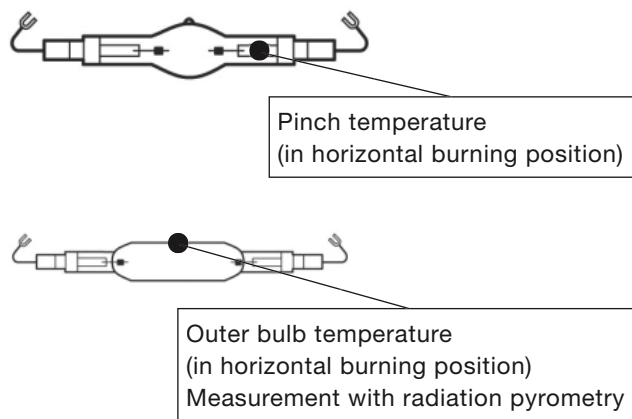

The temperature limits for lamps where only one burning position is permitted are determined in the allowed burning position.

7.2 Influence of ambient temperature on ballasts and luminaires

As the ambient temperature increases, the temperature of the luminaire components also increases at the same rate. The lamp reacts to a higher ambient temperature with an increase in lamp voltage and lamp wattage. This can accelerate corrosion and aging processes. An increased re-ignition peak can result in failure by the lamp going off at an earlier point in the service life.

Higher temperatures at choke and ignition unit mean a reduced service life for these parts or also earlier failures. The limit temperatures for chokes is generally 130 °C, and 70 °C to 105 °C for ignition units (consider manufacturer's instructions). A higher ambient temperature means that luminaires are increasingly switched off, triggered by the thermal protection.

It can therefore be assumed that the high ambient temperature has a distinctly negative influence on the service life of lamps and luminaires.

Luminaire design has a great influence on the temperature of the parts. Heat-generating parts such as chokes and filter coils can be mounted on materials with good heat conducting properties and adequate ventilation openings to ensure there is ample heat dissipation. The greatest possible spacing should be kept between heat-sensitive parts such as ignition unit and capacitors, and heat-generating parts. If necessary, forced cooling should be provided by ventilation elements.

At the end of the lamp service life, far higher temperatures than normal can occur in the pinch area caused by outer bulb discharges (see also chapter 6.2 "Failure mechanisms of metal halide lamps"). The socket in the immediate vicinity of this point must be rated for that temperature.

7.3 Lamp holder

Metal halide and high-pressure sodium lamps have many different bases. These include for example RX7s, Fc2, G8.5, GX10, GX8.5, GU6.5, G12, G22, GY22, E27, E40 and K12s, depending on whether the lamps are single- or double-ended. All sockets must be rated for the typical conditions for discharge lamps, i.e. high ignition voltage and high temperatures. It is up to the user to make an appropriate selection and to ensure that the lamp holders are installed correctly according to the corresponding regulations (e.g. IEC 60598 / VDE 0711, IEC 60335 / VDE 0700). Sockets consist of several parts, each with their own function limits. Exceeding these limits causes premature failure of the sockets.

Temperature and ignition voltage are critical, because the effects of exceeding the limit values are often only detected after a longer period of time. This results in a sudden, not gradual, decrease in service life.

Please note that lamps vary in wattage (permitted up to +12%) and temperature, and that according to IEC 60926, ignition units may generate output voltages of up to 30% above the nominal value.

• Ignition voltages:

The socket must be rated for the corresponding ignition voltage.

When mounting the socket and the supply leads in the luminaire, it is important to consider the required creepage distance and clearance, as well as distances in the insulation. The luminaire IEC 60598-1 standard corresponding to EN 60598-1 defines the safety requirements for ignition voltage regarding creepage and clearance distances. Particularly when using high-pressure discharge lamps with Edison bases E27 and E40, care is required to ensure that the sockets are approved for discharge lamps. Suitable sockets are marked with the value to max. "5 kV" and comply with the increased creepage and clearance distances required in the socket standards IEC 60238 or EN 60238 (VDE 0616 Part 1). In the same way, the other base systems are subject to the socket standards for special sockets IEC 60838-1 or EN 60838-1 (VDE 0616 Part 5).

CAUTION : Do not use sockets for incandescent lamps, e.g. E27 or R7s. Sockets for discharge lamps must be used to handle corresponding ignition voltage.

• Temperature code Txxx (continuous use temperature)

This is the highest temperature for which the socket was designed. The temperature of special holders is measured at the socket contact according to 60838-1 (all holders for high-pressure discharge lamps except Edison sockets). If the heat resistance of insulation, terminals and leads deviate from this temperature limit, then separate limit values are stated. In the case of Edison sockets (according to IEC 60238), the rated temperature is valid for every point in and on the socket.

At the end of the lamp service life, higher temperatures than normal can occur in the pinch area caused by outer bulb discharges. The socket must be rated accordingly (see also chapter 6.2.1 Leaking arc tube).

When replacing such lamps, the socket must always be checked for signs of damage and replaced if necessary, because a damaged socket would also damage the new lamp.

- **Rated current and rated voltage**

The socket must be chosen according to the lamp parameters. The rated current in this case is the highest continuous load current, and the rated voltage is the highest voltage for which the socket is designed.

CAUTION! Certain sockets such as G12 and E27 are used for different wattage levels. When inserting or exchanging lamps make sure that the right lamp for the respective ballast is chosen. Otherwise the lamp is operated incorrectly, and the socket may possibly not be rated for the deviating operating conditions.

- **Fastening parts**

The connection parts, e.g. blade terminals, must be chosen according to the requirements (e.g. temperature, current load, corrosion resistance).

- **Connection leads**

The connection leads must be rated accordingly for the conditions of use with regard to heat and UV-resistance, mechanical strength, electric strength and current carrying capacity.

PTFE leads are normally not suitable to handle ignition voltage. In practice, silicone-insulated leads with 3.6 mm outer diameter have proven effective for discharge lamps. For lamps with immediate hot re-ignition, silicone insulation 7 mm thick should be used together with fiberglass inlay.

While the lamp is starting up, it is possible for the start-up currents to briefly exceed the nominal values, which must be taken into consideration when rating the socket. Up to 1.5 to 2x the operating current can flow during the start-up phase (within the first 5 minutes of operation).

- **Isolation of Contact Connections**

Care must be taken to electrically isolate the connection contacts in the installation procedure if this is not safeguarded by the socket alone.

- **Lamp pins**

Only use lamps with clean metallic contacts. Oxidized contacts result in high transition resistances and generate high operating temperatures. The surface of the lamp pins must be smooth and must not show any visible traces of mechanical machining in the area of contact with the socket

contact, as otherwise the socket contacts can be damaged.

7.4 Leads to luminaires

The lead cables to the luminaires must be rated for their conditions of use, taking account of adequate heat and UV-resistance, mechanical strength, electric strength and current carrying capacity, as well as giving due consideration to the effect of cable lengths (e.g. when remote mounting is required). Cable resistance grows linear to cable length. The resulting voltage drop across the cable reduces the effective supply voltage. The effects are described in chapter 3.1.3 *"Influence of deviations in supply voltage"*.

Various factors must be considered when choosing leads in the lamp circuit:

- The voltage drop across the lead depends on the flowing current and can be reduced by using cable with a larger cross section.
- It should also be borne in mind that cable resistance increases with higher ambient temperature. The resistance of a copper cable rises by about 10% for an increase in temperature of 25 °C.
- Consideration must be given to the voltage drop in the outgoing and incoming cable.
- 230 V systems are more sensitive to additional line resistance than 400 V systems.

In applications demanding the lowest possible colour scattering, the supply conditions should be approximately the same, i.e. supply voltage or line resistance should be equivalent.

7.5 Maintenance of lighting systems with metal halide lamps

Since March 2003, the EN 12464-1 standard applies to interior lighting systems throughout Europe. If a lighting system is being planned according to this standard, it is necessary to draw up a maintenance plan. This has to take into account influences causing a drop in luminous flux in the system during the course of the service life, such as dirt depreciation of luminaires and the room itself, together with the aging of the lamps and lamp failures. The maintenance factor replaces the previous planning value.

Maintenance factor $MF = LLMF \times LSF \times LMF \times RMF$

LLMF = lamp luminous flux maintenance factor

LSF = lamp survival factor

LMF = luminaire maintenance factor

RMF = room maintenance factor

Example for a maintenance plan

Maintenance plan

Only regular maintenance can ensure compliance with the stipulated illuminance levels in the EN 12464 standard for the lighting system. The following maintenance intervals must therefore be followed.

Room

Type of surrounding: Normal
 Maintenance interval: every 2 Years

Luminaire XXX

Influence of reflections from the room surfaces: medium (Room index $1.1 < k < 3.75$)
 Luminaire characteristics: direct
 Reflector type: B – Reflector open at the top
 Lamp type : Metal Halide lamp (CIE)
 Ballast: CCG
 Operating hours per year: 3000
 Maintenance interval (Luminaire): every 2 Years
 Maintenance interval (Lamp): every 3.5 Years
 Failed lamps are replaced immediately: Yes
 Maintenance factor: 0.61

Maintenance instructions:

Lamps must be replaced with suitable replacement lamps of the same characteristics (luminous flux, light color, color rendering). Any existing starters should also be replaced during relamping.

The room and surfaces deflecting light are to be maintained so as to preserve the original reflection characteristics.

Always comply with the manufacturer's cleaning instructions.

Measures to comply with a required minimum lighting level include regular cleaning of the room and the luminaire, as well as timely replacement of the lamps. Timely replacement of the lamps also ensures avoidance, for the most part, of undesirable effects at the end of the lamp service life.

When compiling the maintenance plan, consideration must be given to the decrease in luminous flux over the course of the lamp service life in the form of the lamp luminous flux maintenance factor (LLMF).

The CIE has stated a general luminous flux curve for metal halide lamps which results in a maintenance factor of 0.68, for example, for 9000 h.

Given the lesser drop in luminous flux in POWERBALL HCl® over the service life compared to standard metal halide lamps with cylindrical tube, the maintenance factor for 9000 h is 0.8.

In practice, this results in the following application cases (see also table 2):

To achieve a constant luminous flux of min. 500 lx throughout the service life, taking cleaning and change intervals into account, the following applies initially:

- Standard lamp and lamp change after 3 years, i.e. for an LLMF of 0.68 (case 1):
962 lx *approx. 17% higher illuminance, i.e. more luminaires*
- POWERBALL HCl® and lamp change after 3 years, i.e. for an LLMF of 0.8 (case 2):
820 lx
- Standard lamp and lamp change for an LLMF of 0.8, here after 14 months (case 3):
820 lx lamp change *required after 14 months*, as 80% of the initial lumens achieved after 3500 h.

Table 2: Comparison of change intervals for different lamp types

		Case 1	Case 2	Case 3
Lamp HCl-T 70 W/830 PB	Maintenance intervall	3 Years	3 Years	1 Year 2 Months
	Operating hours /year	3000	3000	3000
	Immediate exchange of defect lamp	yes	yes	yes
	LLMF	according CIE	POWERBALL HCl®	according CIE
	RMF	0,95	0,95	0,95
	LWF	0,8	0,8	0,8
	LSF	1	1	1
	LLMF	0,68	0,8	0,8
	MF	0,52	0,61	0,61

Diagrams showing luminous flux behaviour and survival rate can be found in the Technical Data of the lamps in the online catalogue.

7.6 Standards and directives for discharge lamps

The international body for issuing standards relating to electrical engineering is the IEC (International Electro Technical Commission). European standards (EN) are usually identical with the IEC standards. In addition to the contents adopted by the IEC, the EN standards also include the requirement to withdraw contradicting national standards within an appropriate period of time. Furthermore, safety standards are listed in the low voltage directive, which is mandatory for the CE symbol and for test marks.

OSRAM products are constructed according to the relevant standards and in compliance with the valid directives.

7.6.1 Standards

The standards for lamps and accessories are broken down into safety and performance standards. While the safety standards stipulate tests regarding electrical, optical and thermal hazards, the performance standards look at aspects such as dimensions, electrical description, luminous flux, service life and stipulation of test procedures.

The following table provides an overview of the key standards for operating high-pressure discharge lamps. It features the IEC standards; the corresponding EN standards bear the same number.

Table 3: IEC standards for discharge lamps and accessories

Lamp			
Safety		Performance	
62035	Discharge lamps (excluding fluorescent lamps) – Safety specifications	60188	High-pressure mercury vapour lamps – Performance specifications
		60192	Low-pressure sodium vapour lamps – Performance specifications
		60662	High-pressure sodium vapour lamps
		61167	Metal halide lamps
		61549	Miscellaneous lamps

Bases, sockets and gauges	
60061-1	Lamp caps and holders together with gauges for the control of interchangeability and safety; Part 1: General requirements and tests
60061-2	Lamp caps and holders together with gauges for the control of interchangeability and safety; Part 2: General requirements and tests
60061-3	Lamp caps and holders together with gauges for the control of interchangeability and safety; Part 3: General requirements and tests
60061-4	Lamp caps and holders together with gauges for the control of interchangeability and safety; Part 4: General requirements and tests
60238	Edison screw lamp holders
60399	Barrel thread for lamp holders with shade holder ring
60838	Miscellaneous lamp holders

Accessories			
Safety		Performance	
60155	Glow-starters for fluorescent lamps	60155	Glow-starters for fluorescent lamps
61048	Auxiliaries for lamps – Capacitors for use in tubular fluorescent and other discharge lamp circuits – General and safety requirements	61049	Capacitors for use in tubular fluorescent and other discharge lamp circuits – Performance requirements
61347-1	Lamp control gear – Part 1: General and safety requirements	–	
61347-2-1	Lamp control gear – Part 2-1: Particular requirements for starting devices (other than glow starters)	60927	Auxiliaries for lamps – Starting devices other than glow starters) – performance requirements
61347-2-4	Lamp control gear – Part 2-4: Particular requirements for d.c. supplied electronic ballasts for general lighting	60925	DC supplied electronic ballasts for tubular fluorescent lamps – Performance requirements
61347-2-5	Lamp control gear – Part 2-5: Particular requirements for d.c. supplied electronic ballasts for public transport lighting		

Accessories			
Safety		Performance	
61347-2-6	Lamp control gear – Part 2-6: Particular requirements for d.c. supplied electronic ballasts for aircraft lighting		
61347-2-9	Lamp control gear – Part 2-9: Particular requirements for ballasts for discharge lamps (excluding fluorescent lamps)	60923	Auxiliaries for lamps – Ballasts for discharge lamps (excluding tubular fluorescent lamps) – Performance requirements
61347-2-12	Lamp control gear – Part 2-12: Particular requirements for d.c. and a.c. supplied electronic ballasts for discharge lamps (excluding fluorescent lamps)		

Luminaires	
60598-1	Luminaires – Part 1: General requirements and tests

EMC	
IEC/CISPR15	Limits and methods of measurement of radio disturbance characteristics of electrical lighting and similar equipment
IEC 61547	Equipment for general lighting purposes – EMC immunity requirements
IEC 61000-3-2	Electromagnetic compatibility (EMC) – Part 3-2: Limits – Limits for harmonic current emissions (equipment input current ≤ 16 A per phase)

Not all lamps are covered by data sheet in the lamp standards, but the application range of every standard applies to all lamps of the corresponding type.

Vibration and impact tests are covered by IEC 60068-2-6 Fc and IEC 60068-2-29 Eb.

7.6.2 Directives

“CE” stands for “Communauté Européenne” (European Community) and indicates compliance of a product with the corresponding European Directives. The CE mark addresses authorities and is applied by the manufacturer. CE marking was created primarily to warrant safe products for the end consumer in the free movement of goods within the European Economic Area (EEA) and its European Community (EC). The CE mark is frequently called a “passport” for the European Single Market. The key directives for lighting products with corresponding compliance confirmed by application of the CE mark are the electromagnetic compatibility directive (EMC, 89/336/EEC) and the electrical equipment directive (73/23/EEC), also called the “low voltage directive”. The low voltage directive demands that the product does not cause any harm to persons, animals and things. Compliance with the low voltage directive can also be verified by compliance with the safety standards.

OSRAM lighting products marked with “CE” fulfill the safety and EMC standards where applicable for the specific product (see table 3).

7.6.3 Certificates

On the initiative of European manufacturer’s associations, European test and certification bodies have agreed to provide a uniform European evaluation of electrical products in order to indicate to the buyer of a product that it is safe and complies with state-of-the-art technology. This resulted in the ENEC agreement and the ENEC mark (ENEC = European Norms Electrical Certification). Prerequisite for being granted an ENEC certificate is compliance of the product with the corresponding European safety and performance standards. The production procedure must have a quality management system (e.g. based on DIN EN ISO 9002). The corresponding certification body carries out regular audits to monitor whether the system requirements are being met. The number next to the ENEC symbol identifies the certification body. All current certification bodies that have signed the ENEC agreement can be found together with the corresponding countries and the register of issued ENEC approvals on the ENEC internet website www.enec.com.

If an ENEC mark is issued for a product by a certification body, then the European certifying bodies participating in the ENEC agreement treat this product as if they had tested and certified it themselves. Further testing and certification by one of these bodies is no longer necessary.

The ENEC mark can be obtained for luminaires for which a European standard exists. Luminaire accessories such as ballasts, ignition units, lamp sockets and capacitors can also be issued an ENEC mark if they satisfy the corresponding EN standard.

7.7 Radio interference

Selected luminaires must comply with the international requirements such as CISPR 15 and CISPR-22 A or B, and in practice, radio interference is low enough so that no negative effects are expected on the environment.

Even though ignition pulses from an ignition unit without cut-out can cause radio interference if with a defective lamp, there are no regulations for this case. The interferences can be extensive. One solution is swift replacement of the defective lamp or use of ignition units with a cut-out feature. These detect the defect or the absence of the lamp and switch off the ignition unit after a limited time period of futile ignition attempts. The unit has to be disconnected from the grid power supply to reset the timer.

7.8 RoHS conformity

All products brought onto the market in Member States of the European Union by OSRAM since 1 July 2006 comply with the requirements of the EC directive 2002/95/EC “on the restriction of the use of certain hazardous substances in electrical and electronic equipment” (RoHS).

As a fundamental rule, our products contain no cadmium, hexavalent chromium, polybrominated biphenyls (PBB), polybrominated diphenylether (PBDE) or lead, and fulfill the requirements of the directive for the use of mercury.

7.9 Optical design of reflectors

7.9.1 Condensate in the lamp

While the mercury in metal halide lamps evaporates completely when operated at full power, the metal halides are in saturated state. There is therefore always a surplus of condensed metal halides at the “cold spot” in the arc tube.

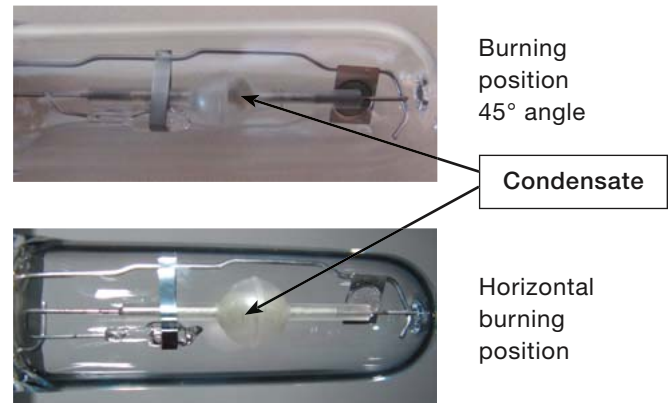

Figure 38: Example for condensate precipitation in the lamp

The balance between condensed and evaporated part of metal halides depends on the temperature of the arc tube wall. The coldest spot of the tube where the metal halides have condensed is usually at the bottom of the tube.

7.9.2 Projection of the condensate

The light radiated from the plasma projects the condensate of the lamp so that the reflector needs to mix the emitted light to ensure homogenous radiation. In particular when the burner is horizontal, the radiation components from the upper half of the burner and the lower half of the burner have to overlap and be mixed during projection. If the reflector cannot ensure this, the condensate of the lamp is projected and appears on a white wall as a yellow mark.

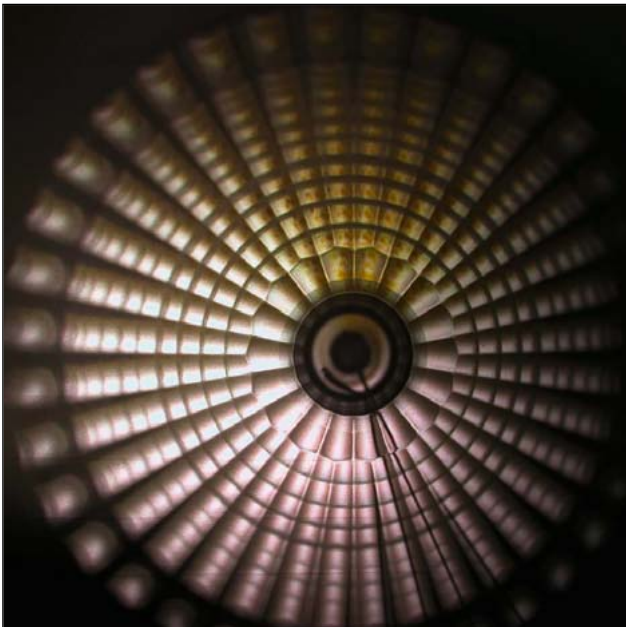

Figure 39: Projection of the condensate by the reflector

7.9.3. Back reflection on the lamp

The luminaire design needs to ensure that no radiation is reflected back onto the lamp as this can cause thermal loads on sensitive parts of the lamp which normally leads to unusually early failures. For a lamp with a quartz arc tube, this may lead to the expansion of the tube or to a leak in the pinch area.

In lamps with ceramic arc tubes, the so-called sealing area at the ends of the capillaries is particularly sensitive: here overheating can lead to increased chemical reactions and then to cracks and lamp failures. A further sensitive component is the lamp's getter.

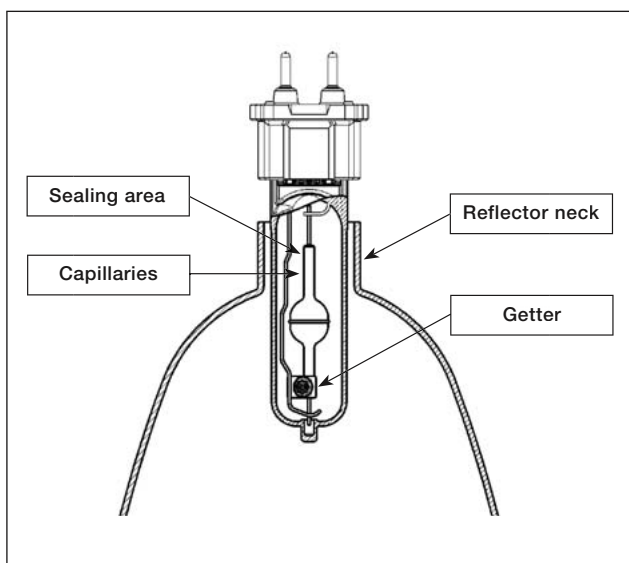

Figure 40: Example of a reflector with a reflector neck over the thermally critical parts of the lamp.

To establish whether or not the luminaire design could cause impermissible thermal damage, the temperature

on the outer bulb and the socket or the pinch area first need to be measured as stated in the catalogues, see also section 7.1.

However it should be noted that even if the temperatures measured on the outside of the lamp lie within the defined tolerance values, this does not necessarily mean that there is no overheating inside the lamp.

Those surfaces closely surrounding the lamp, such as the reflector neck, diffuser tube and glare shield caps, reflect back on the lamp. Likewise, elliptical reflectors radiate back onto the lamp if the burner is not positioned correctly in the burner point of the reflector. In these cases the lamps may also suffer damage even if the temperatures measured on the outside of the lamp lie within the defined tolerance values.

The following recommendations are made:

To avoid glare, the glare shield caps often used for halogen bulbs or the glare shield rings on lamps with double-sided burners such as HCl[®] may not be used. Instead, the glare protection for these lamps is effected by using e.g. honeycomb filters or "anti-glare baffles" or "hoods" attached to the outside of the luminaire.

The glare can also be reduced by using protected lamps, such as HCl[®]-TX/P, because the fact that there is no front glass at the luminaire means that there is no reflex glare on the front glass.

To achieve a homogenous colour radiation, faceted and matt reflectors should be used. Diffuser tubes around the lamp are not suitable.

In lamps with a reflector casing, the reflector should be smoothly cut at the opening and should not have a neck.

It is more difficult in cases where the reflector itself comprises the outer part of the luminaire. If a reflector neck is used here, e.g. to prevent the emission of light scatter, this leads, e.g. in ceramic lamps to a higher temperature load in the socket-based capillaries.

The extent of the damage depends on the following parameters:

- Extent of the spatial covering of the reflector neck and the capillaries: less is better
- The diameter of the reflector neck: bigger is better
- Level of reflection of the reflector neck: matt is better than mirrored
- Overall volume of the reflector: bigger is better

The service lives stated by OSRAM only apply to lamps operated in luminaires that do not reflect back on the lamp. They are based on a switching rhythm 11 h ON, 1 h OFF.

If back reflecting construction elements are used in the luminaire design, the guarantee for the lamps can be restricted or even completely suspended.

It is therefore recommended contacting OSRAM if there is any doubt during the design stage.

In the case of lamps with back reflecting construction elements, tests should always be carried out to ascertain whether the extent of the lamp damage can at least be assessed as minimal.

It is useful to do comparative burning tests with non back reflecting luminaires. If in this case of e.g. ceramic lamps, visible deposits in the outer bulb of the lamps occur at an early stage in the tested luminaires, the burner has overheated due to back reflection.

Due to the fact that the failure rate of ceramic lamps depends on the switching frequency, a lamp test of this kind can be accelerated by increasing the switching frequency to e.g. 3h ON, 1h OFF.

8 Light and colour

Light is the part of the electromagnetic spectrum which can be seen with the eye. By definition, the perceptible wavelength range is 380-780 nm, although radiation can also be perceived as colour in the near infrared range. Similar to visible light, ultraviolet and infrared variation belong to the electromagnetic spectrum.

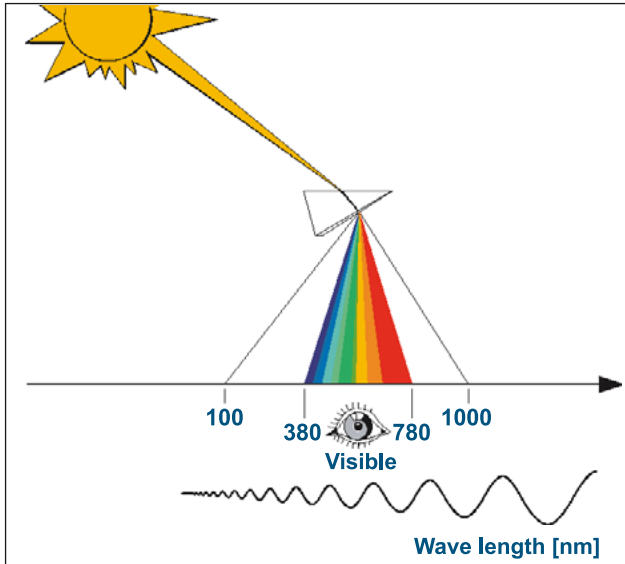

Fig. 41: Visible light as part of the electromagnetic spectrum

Different wavelengths can be perceived to different extents. The maximum of the sensitivity curve for photopic vision is at 555 nm. The light output (luminous flux) is ascertained by multiplying the physical radiation output with the eye sensitivity curve $V(\lambda)$ (see Fig. 43).

If the entire radiation output is emitted monochromatically in the wavelength of maximum eye sensitivity (555 nm), then the theoretical maximum luminous efficacy is 683 lm/W. With uniform distribution of radiation over the range of 380 – 780 nm, approx. 196 lm/W is possible.

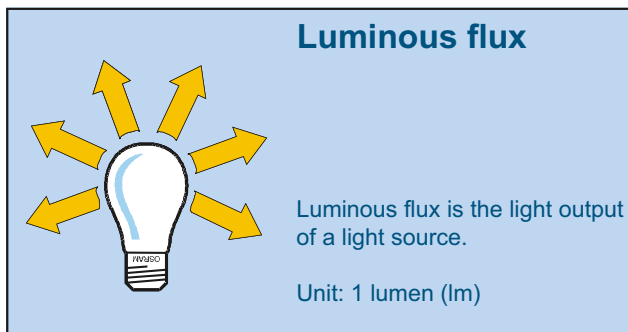

Fig. 42: Definition of luminous flux

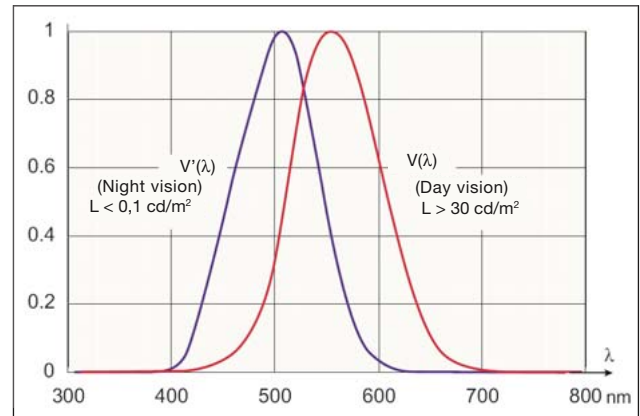

Fig. 43: Spectral brightness sensitivity $V(\lambda)$ for photopic vision and $V'(\lambda)$ for scotopic vision

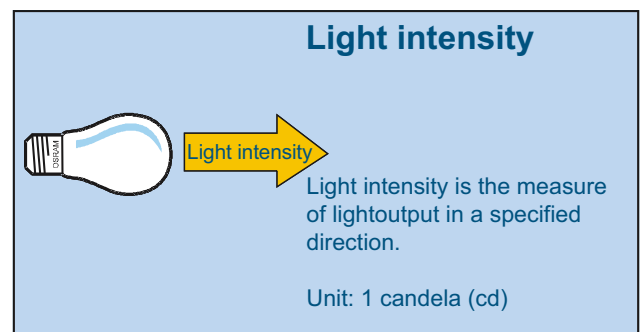

Fig. 44: Definition of luminous intensity

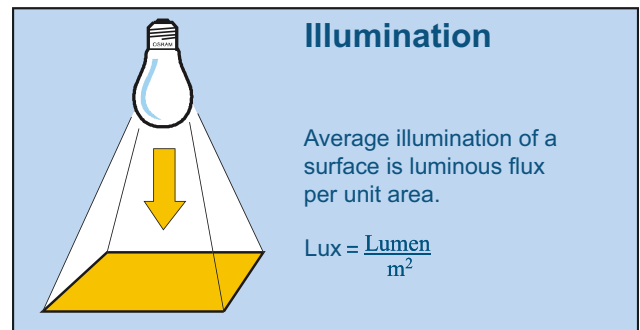

Fig. 45: Definition of illuminance

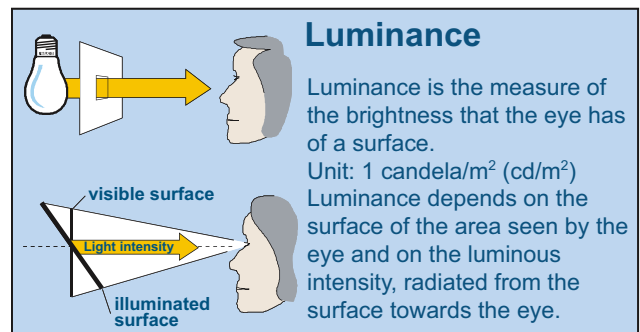

Fig. 46: Definition of luminance

Luminous efficacy = $\frac{\text{Irradiated light in Lumen (lm)}}{\text{spent electrical power in watt}}$ (Gl. 9.1)

8.1 Night vision

The luminous flux, measured in lumens, is the irradiated output of a light source evaluated by the eye. It is defined by multiplying the physical radiation output with the eye sensitivity curve $V(\lambda)$. Standard luminous flux measurements only consider the reaction of the eye at high illuminance levels (photopic vision) as is typical for daylight and indoor illumination. Luminous flux measurements measure photopic light as perceived by the central region of the eye.

When the illumination level is very low, for example at night by star light, the vision conditions are said to be scotopic. The reaction of the eye changes under these circumstances. The eye sensitivity curve for low illumination levels (less than 0.1 cd/m^2) is the $V'(\lambda)$ curve, as shown in the figure 43.

Sensitivity for red and yellow light decreases, while there is better perception of blue light. When luminous flux is measured under photopic conditions, this does not correspond to what the eye perceives at low light levels. The reaction of the eye does not change suddenly from high to low illumination levels. The change is gradual when the illumination level decreases to

twilight and typical street lighting conditions. This is called mesopic vision which lies between photopic and scotopic vision.

The change in eye sensitivity comes from the presence of two types of light receivers on the retina: rods and cones. The rods are responsible for vision under low illuminance and are located in the peripheral field of vision. The rods are sensitive to scotopic light while the cones react to photopic light. When the illumination level decreases, the rods are therefore more active, while the cones become inactive.

The effective, seen “lumen” will differ from the measured photopic luminous flux. When the illumination level falls, the effective “luminous flux”, e.g. of yellow high-pressure sodium lamps, decreases while the effective “luminous flux” of white light with a higher share of green/blue light increases.

Figure 47 shows the radiation output of a HCI®-TC 70 W/NDL and a NAV®-T 400 W Super 4Y, normalized in the interests of comparability to a luminous flux of 1000 lm. The diagram shows the relative distribution of the radiation in the spectrum.

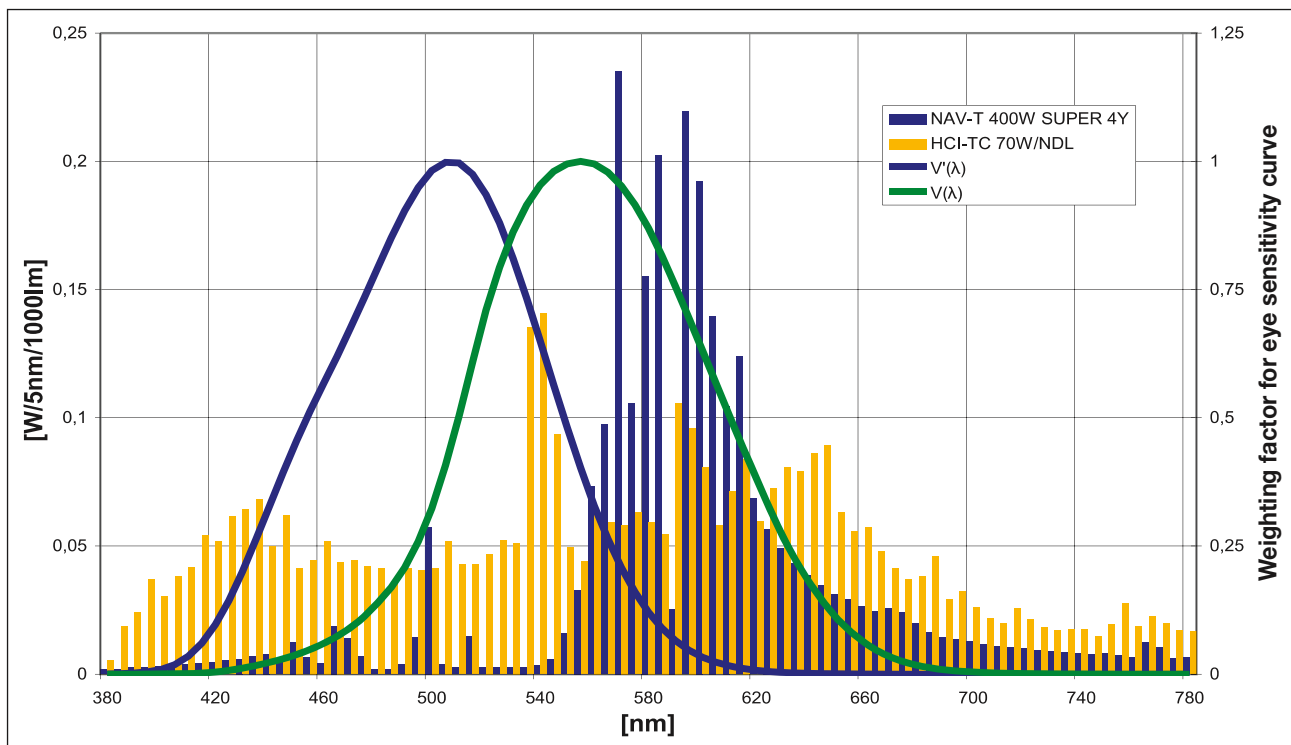

Fig. 47: Physical radiation output in W per 1000 lm and per 5 nm

In Fig. 48, the physical radiation output has been multiplied by the $V(\lambda)$ curve to ascertain the luminous flux per 5 nm in each case. Integration of the values for all wavelengths between 380 nm and 780 nm results in the specified 1000 lm for both light sources.

The NAV® lamp radiates more light in the range around 580 nm, which is near the maximum of the $V(\lambda)$ curve. This contributes to a high luminous efficacy. On the other hand, there are some gaps in the spectrum, particularly in the blue part of the spectrum, which is responsible for the poorer colour rendering compared to the metal halide lamp.

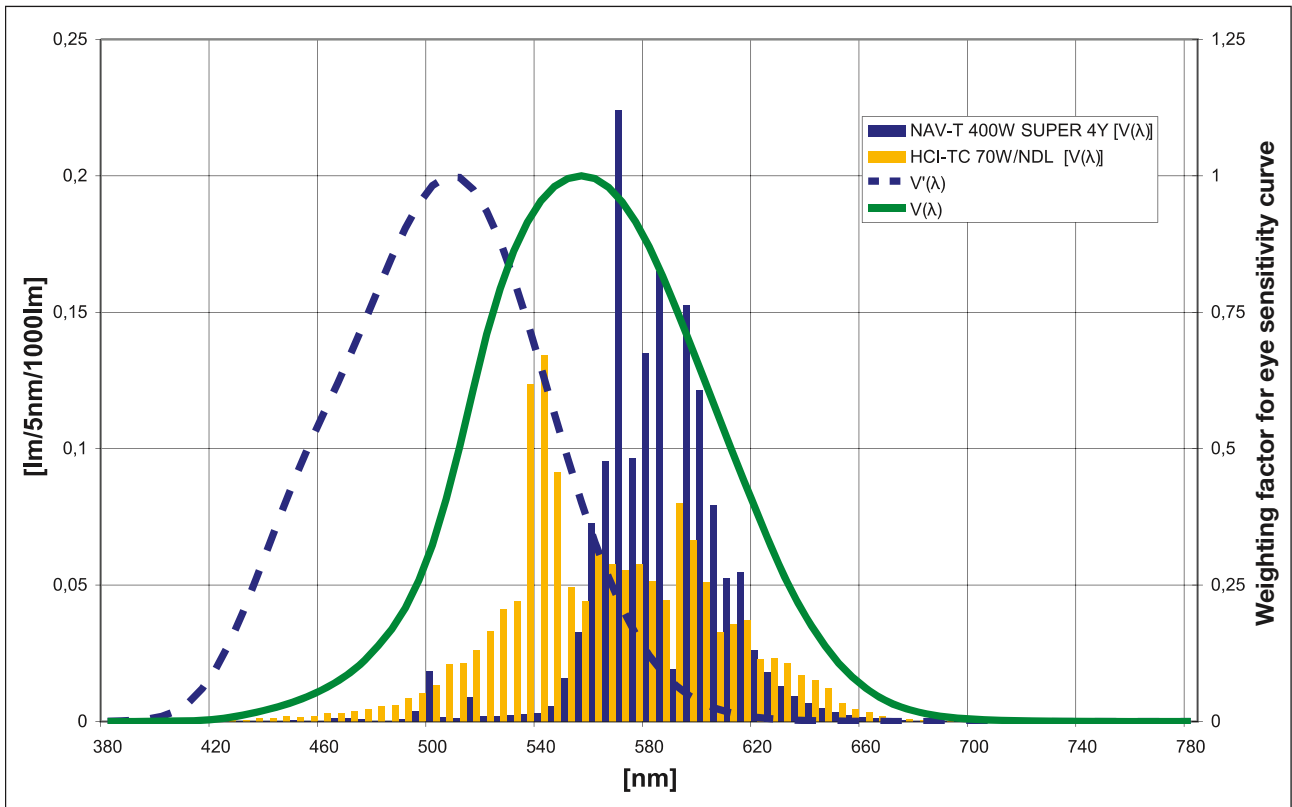

Fig. 48: Relative luminous flux in lumen per 1000 lm and per 5 nm

In Fig. 49, the radiation output has been multiplied by the $V'(\lambda)$ curve for illumination levels below 0.1 cd/m^2 . The diagram shows that the perceived illumination level of the metal halide lamp is far higher (in this example about three times higher) than the high-pressure sodium vapor lamp.

Illumination levels in street lighting are higher than 0.1 cd/m^2 , resulting in a sensitivity between photopic and scotopic vision.

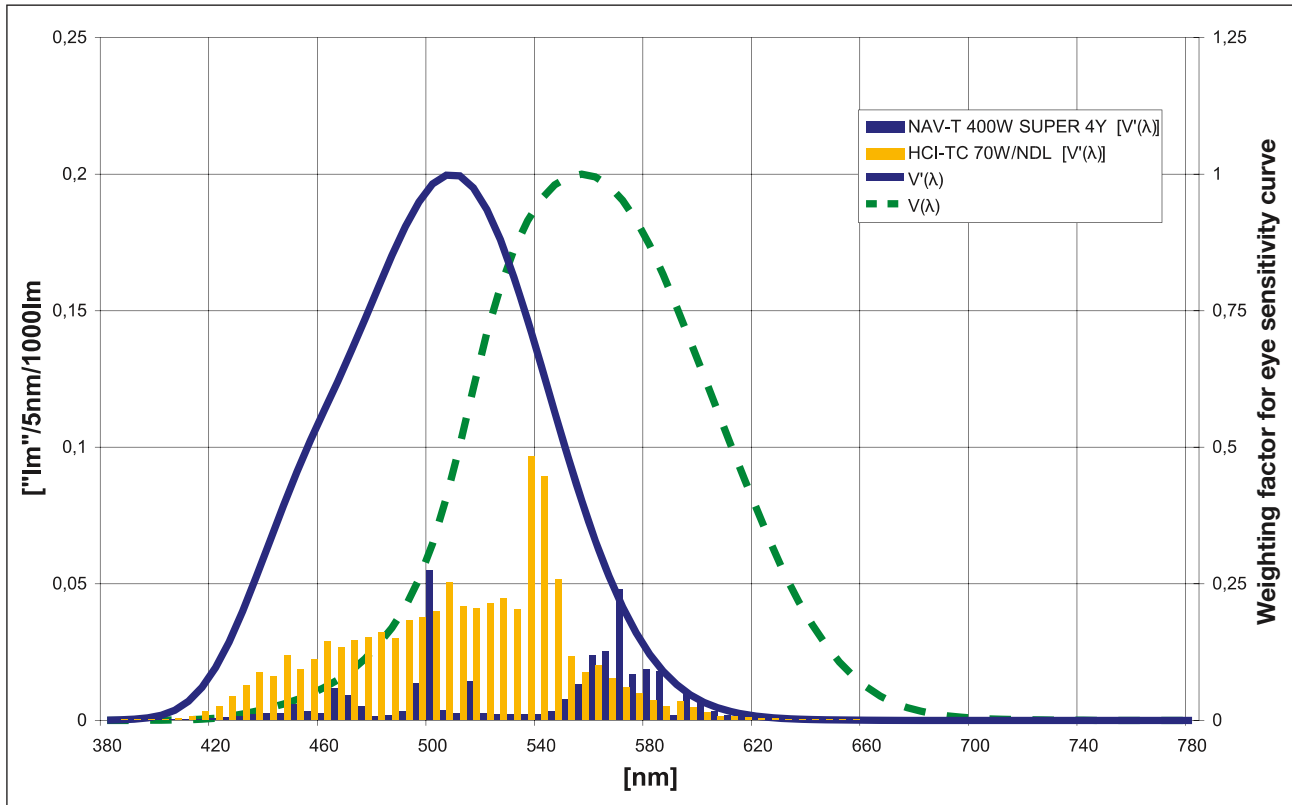

Fig. 49: Equivalent to luminous flux, taking account of an eye sensitivity curve at a low illumination level $V'(\lambda)$

8.2 Colour rendering

Colour is a sensory impression conveyed by the eye. The evaluation of a colour stimulus by the eye causes a uniform effect (colour stimulus specification). This can be described by colourimetric numbers (e.g. x , y and z in the CIE 1931 or CIE 1976 colour space or L , a and b in the CIE 1976 ($L^*a^*b^*$) space or W , U and V in the CIE 1964 colour space (W^* , U^* , V^*)). But the perceived colour (the subjective impression) depends on the general conditions (colour mood, surrounding surfaces, luminance).

The primary colours, i.e. saturated monochromatic colours, run around the periphery of the colour triangle. An ideal black body (or Planck radiator) radiates an electromagnetic spectrum depending on its temperature. The colour thus depending on temperature is depicted in the Planck curve, this is the so-called "colour temperature". Colours on the Planck curve are marked with the corresponding colour temperature; chromaticity coordinates deviating only slightly from the Planck curve (within the range of the Judd straight lines, corresponding to a distance of approx. 5.4 threshold value units) are marked with the correlated colour temperature.

One way of showing the colour impression is the standard chart as per DIN 5033 – basic stimulus.

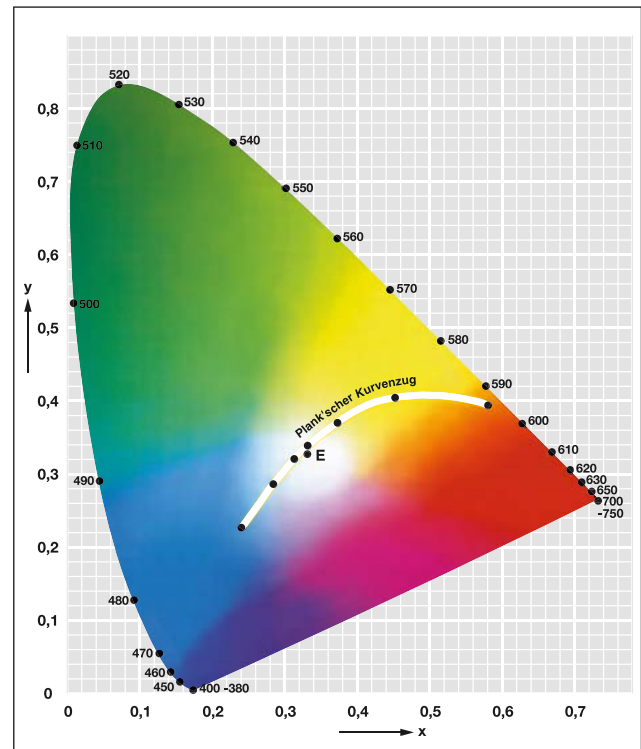

Fig. 50: Standard colour chart as per DIN 5033

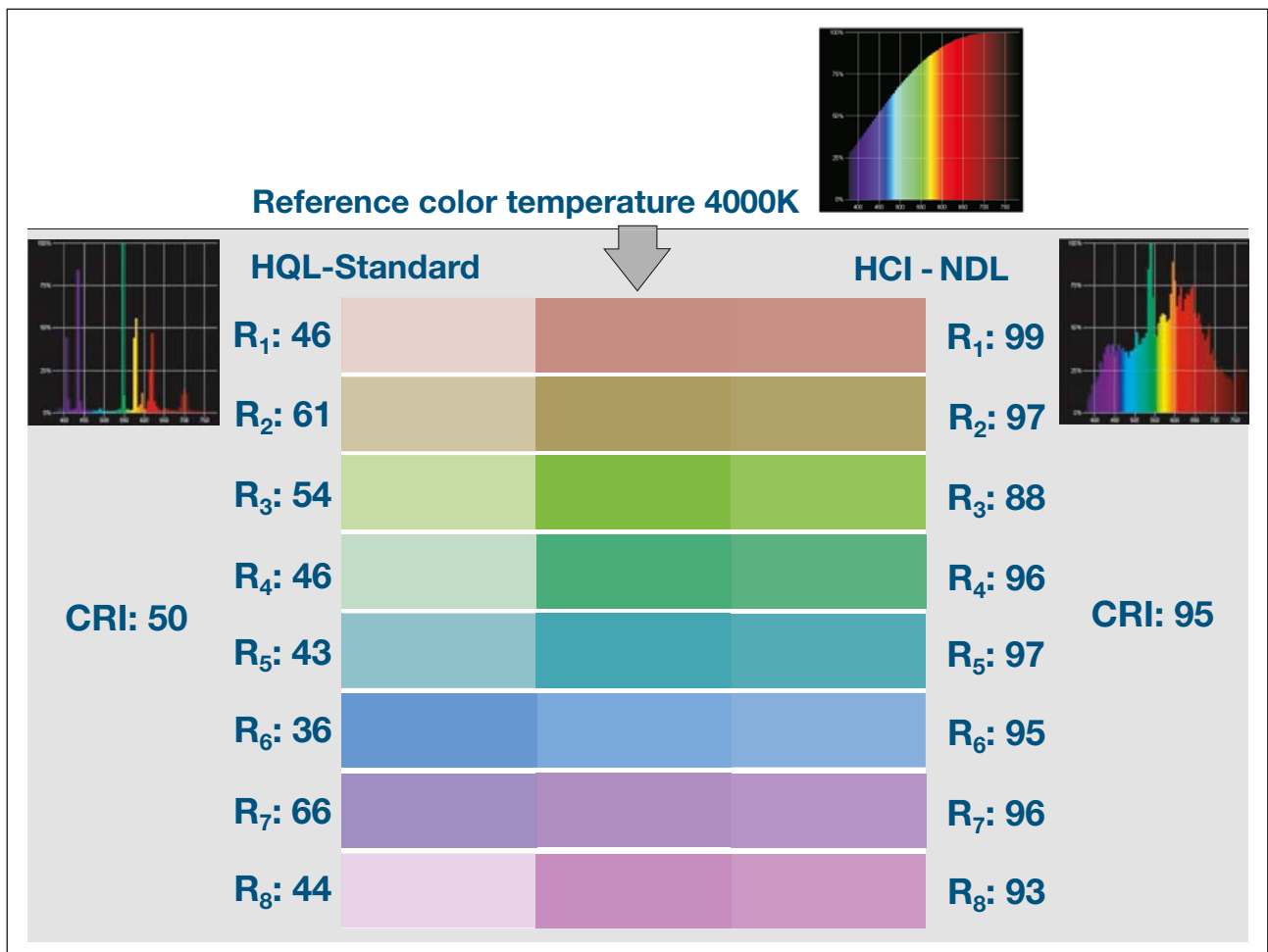

Fig. 51: Defining the colour rendering indices in comparison for two light sources

Larger deviations are associated with a clear tint. The distance to Planck is also known as the chromaticity gap Δc .

Colour rendering is specified by irradiating defined test colours in succession with a reference source (an ideal Planck radiator with the temperature and therefore colour temperature of the test light source) and with the test light source. The specific resultant colour shift ΔE_i is defined for every test colour i in the uniform colour space CIE 1964 (W^* , U^* , V^*).

The specific colour rendering index R_i is defined as follows

$$R_i = 100 - 4.6 \Delta e_i$$

Every special colour rendering index can therefore reach a maximum value of 100 when the test colour appears identical under reference and test light source. Negative values are also possible with greater deviations (and hence larger ΔE_i).

8.2.1 Test colours from standard DIN 6169

The arithmetic mean from the first 8 test colours (see Table 4) shows the general colour rendering index CRI or R_a .

The general colour rendering index results in the colour rendering levels for light sources given in Table 5.

Table 4: Test colours from DIN 6169

Testcolours				
R1 – Dusky pink			R2 – Mustard yellow	
R3 – Yellow green			R4 – Light green	
R5 – Turquoise blue			R6 – Sky blue	
R7 – Aster violet			R8 – Syringa violet	
Saturated colours and additional test colours				
R9 – Red			R10 – Yellow	
R11 – Green			R12 – Blue	
R13 – Skin colour			R14 – Leaf green	

Apart from the first 8 colour rendering indexes, DIN 6169 also defines other test colours, which are four saturated colours and additional test colours. The further test colours permit a more precise description of the colour rendering properties of the light source. In principle it is possible to define any random number of many different test colours.

Table 5: Colour rendering levels

Evaluation	Colour rendering level	Colour rendering index CRI
Very good	1A	≥ 90
Very good	1B	80 – 89
Good	2A	70 – 79
Good	2B	60 – 69
Suboptimal	3	40 – 59
Suboptimal	4	20 – 39

Thanks to a higher possible wall load, the colour rendering properties when using POWERBALL® technology have been visibly improved compared to the lamp with cylindrical ceramic arc tube. A further improvement

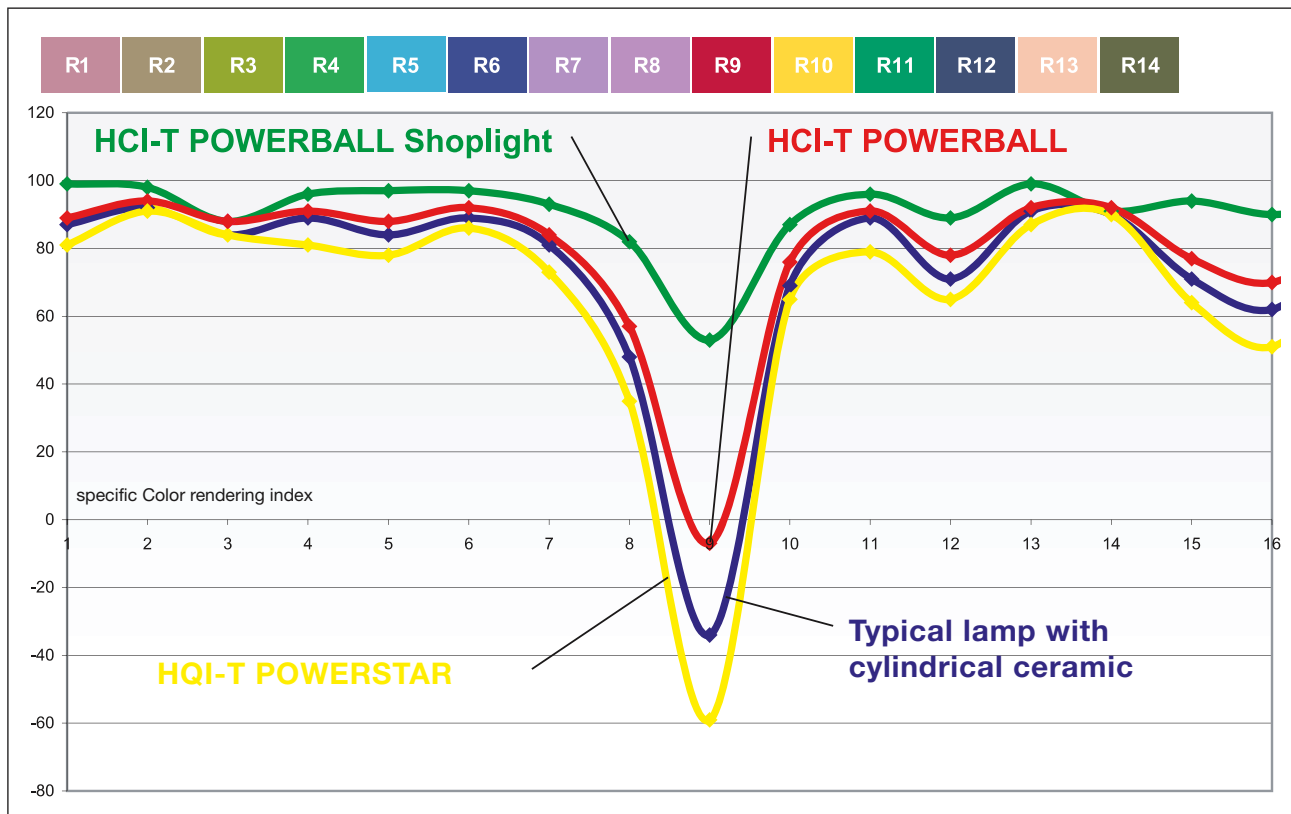

Fig. 52: Comparison of the specific colour rendering indices for various metal halide lamps

has become possible due to additional adaptation of the HCl® Shoplight, which achieves the best colour rendering properties of all metal halide lamps. Figure 49 shows the values of the colour rendering indices 1 to 14 for four different lamp types with the correlated colour temperature of 3000 K. The advantages can best be seen for colour rendering index R9 for saturated red, but the superiority of POWERBALL® technology is also apparent for the other colour rendering indices.

8.3 Light and quality of life

It has been a known fact for many years that as well as its known visual effects, light also has other biological effects on the human body. The most acknowledged effect is the way light influences the day-and-night cycle. This influence is also perceived by the eyes, not however via the vision center in the brain but via other nerve cells that affect the pineal gland and hence the forming of the sleep hormone melatonin. Bright light in the night suppresses the formation of melatonin,

reducing the level of melatonin in the bloodstream. This is called melatonin suppression. (see Fig. 53).

Scientific studies on how light forms or suppresses the sleeping hormone melatonin have shown that together with the visual path which is responsible for vision, there is also a non-visual path which, independent of the visual system, controls melatonin production and therefore the circadian rhythm (daylight rhythm).

While the visual path leads directly from the eye to the vision center of the brain via the optic nerve, the non-visual path is coupled via the suprachiasmatic nucleus (SCN) to the pineal gland and controls melatonin production. This process is relatively slow, in time constants of several minutes, while the process of vision takes place within a few 10 ms.

The SCN is a collection of several thousand nerve cells, located above the intersection of the optic nerves (chiasma). This is deemed today to be the main regulator of the inner clock (master clock).

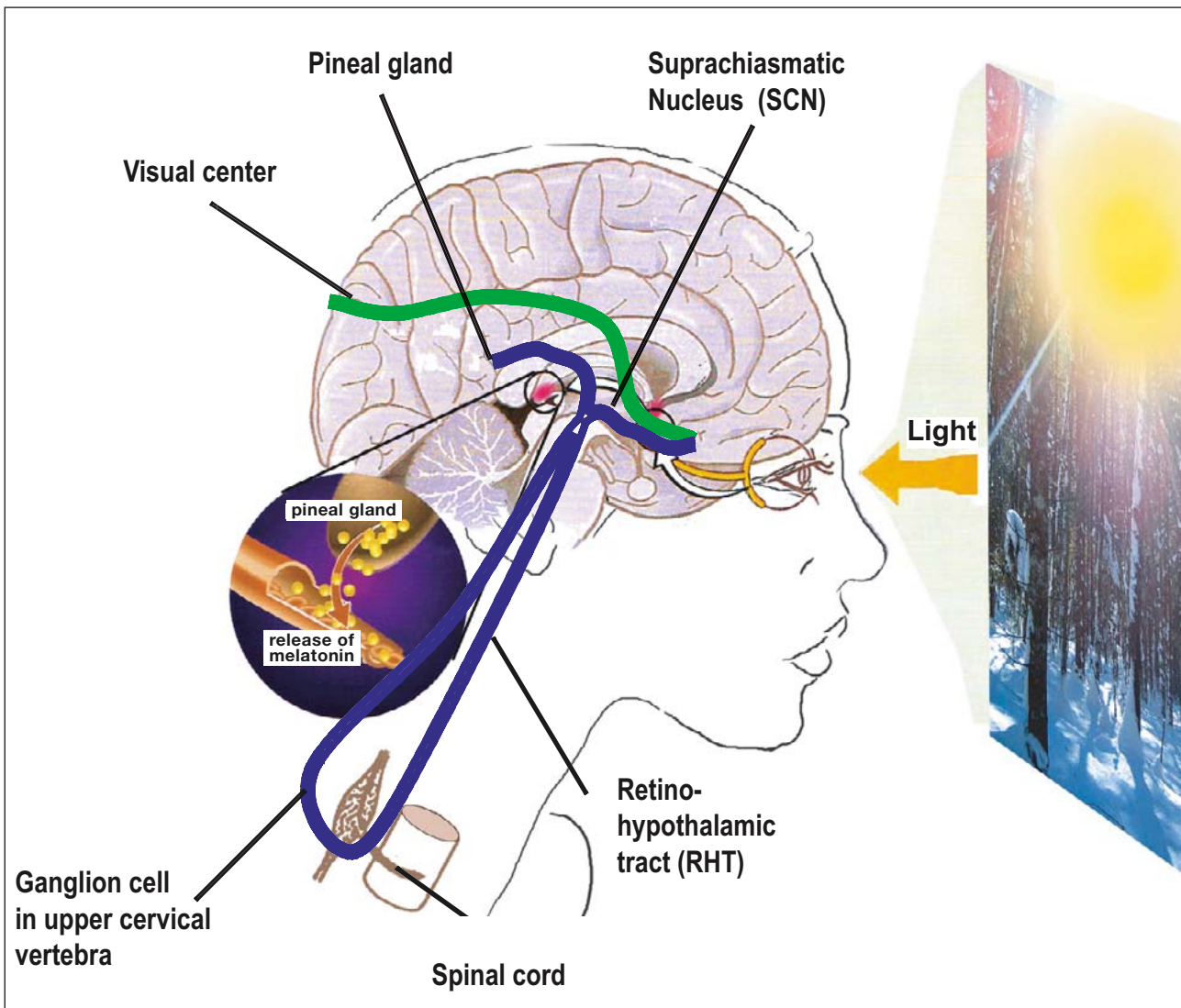
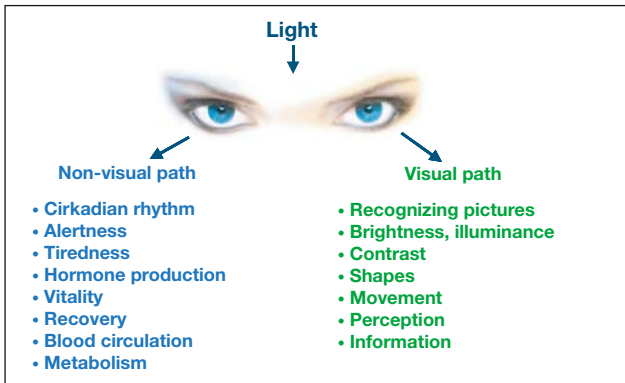

Fig. 53: How light affects on the human brain

And so we distinguish between the visual path, responsible for all visual tasks such as recognizing pictures, perceiving brightness, contrast, shapes, etc., and the non-visual path, or also “biological path”, which controls in particular the circadian rhythms and also influences in the daytime our alertness and mental performance and also biological functions such as hormone production, the blood circulation and the metabolism.

The non-visual path is essentially independent of the visual path.



Scientific studies (Prof. Brainard, Thomas Jefferson University, Philadelphia) have established that melatonin suppression depends not only on brightness but also on the wavelength of the light used. Light in the blue spectral range of about 460 nm has the strongest effect on suppressing melatonin.

The course of the sensitivity curve measured by Brainard for melatonin suppression shows no correlation to the course of the previously mentioned eye sensitivity curves for the red, green or blue photoreceptors in the eye.

This made it apparent that there is a further previously unknown type of light-sensitive cell in the eye responsible for the circadian effect of light.

Prof. Gall from the “Lichttechnisches Institut” at the University of Ilmenau has recognized that the sensitivity curve for melatonin suppression published by Brainard is very similar to the known curve $V(\lambda)$ which describes eye sensitivity for seeing brightness. Only the spectral position is shifted towards blue.

The curve $C(\lambda)$, suggested by Gall, serves today as the foundation for a measuring system for circadian lighting data, defined in DIN V 5031-100. These weighting factors can be taken into account in order to consider the biological effect of light sources.

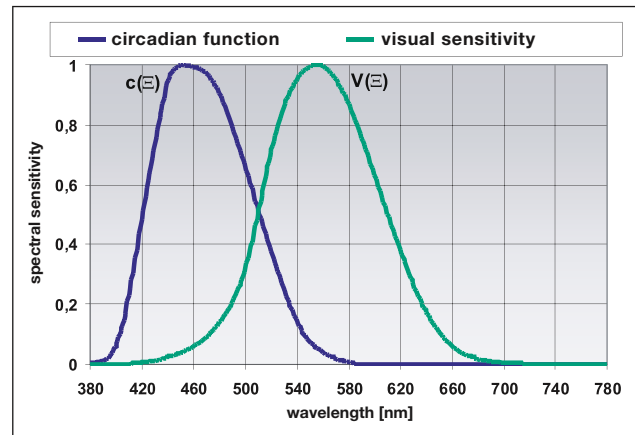

Fig. 54: Definition of a circadian function $C(\lambda)$ by Gall et. al. in analogy to the photometric function $V(\lambda)$ as standardized by the CIE.

8.4 UV radiation

The metal halide lamp standard IEC 61167 describes the effective UV-radiation output and specifies limit values in the respective lamp data sheets. This means that the UV radiation of the lamp in the range 250 – 400 nm is weighted with a so-called evaluation function (see figure 55) (similar $V(\lambda)$ -evaluation of visible radiation).

This evaluation curve shows the generalized sensitivity of human tissue to UV radiation over wavelength and has been defined by the ICNIRP (International Commission on Non-Ionizing Radiation Protection).

This evaluation curve is used today by nearly all national and international bodies (standardization, professional associations, etc.). The ACGIH (American Conference of Governmental Industrial Hygienists) uses this evaluation for workplace guidelines.

The NIOSH (National Institute for Occupational Health and Safety) is an American federal authority that researches occupational health and safety and issues corresponding recommendations.

The maximum daily dose (8h working day) permitted according to the ICNIRP is 30 J/m². With a mean illuminance of 500 lx, this dose is achieved with an effective UV radiation of approx. 2 mW/klm. The IEC 61167 data sheets for metal halide lamps indicate the maximum values of the generated effective UV radiation. IEC 62035 states the limit values for UV radiation (2 mW/klm resp. 6 mW/klm) for high-intensity discharge lamps as an indication for the luminaire manufacturer.

OSRAM metal halide lamps comply with the limit values of 2 mW/klm or even go below the limit considerably.

Exceptions are the HQI® lamps without outer bulb with the power of 1000 W and 2000 W. Here special safety precautions have to be met by the luminaire.

Standardization of UV variables per “klm” or “lm” offers the advantage of being able to make direct comparison of the relative radiation shares of various lamp types and wattage classes with regard to the same application illuminances.

As a comparison:

- Tubular Fluorescent T8 & T5 have an ACGIH UV value of approx. 0.2 mW/klm (with possible minor fluctuations depending on wattage class and light colour).
- Compact lamps have a lower 0.03 mW/klm

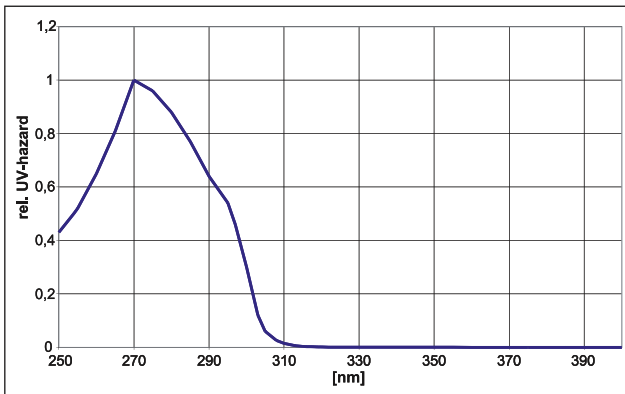

Fig. 55: Evaluation function for the sensitivity of human tissue to UV radiation as per ICNIRP

8.4.1 Fading effect

The colour change in light-sensitive materials resulting from irradiation with light sources depends on

- irradiance or illuminance,
- spectral distribution of the radiation from the light source,
- spectral object sensitivity (effect function) and
- irradiation time.

If daylight contributes to the lighting e.g. via skylights or shop windows, this has to be considered as part of the irradiation as well. Daylight contains considerable amounts of light in the UV range und short-wave visible light.

In new objects, colour change is strongest during the initial period of light exposure. Old wall carpets for example which have been exposed to light for centuries, show hardly any remaining sensitivity to radiation.

Fading occurs not only due to UV but also with short-wave visible light, depending on the spectral object sensitivity (effect function) of the irradiated object. There is plenty of information on this subject in the Division 6 report of the CIE (CIE technical collection) entitled “On the Deterioration of Exhibited Objects by Optical Radiation”. Although this deals with objects in museums, the results are also applicable for example to shop window lighting. A stronger fading effect could be achieved by stronger focusing of the light or by a higher luminous flux in the lamp.

A numerical definition of colour change generated by irradiation must be expressed in the form of colourimetric differences ΔE^*_{ab} . In this way, it is possible to express exactly every fading, blackening and yellowing or basically every colour change. Effective radiation resulting in a colour change of exactly $\Delta E^*_{ab} = 1$, is called threshold effective radiant exposure. This value is important, as experience shows that colour changes in this magnitude can be perceived by the average observer on comparing unexposed areas of a sample with exposed parts.

Other limit values can be used ($\Delta E^*_{ab} = 2, 3, 4$, etc.) if the correspondingly larger colour differences are acceptable.

8.4.2 Protective measures to reduce fading

Every protective measure must refer to a reduction in effective radiant exposure Hdm. Effective radiant exposure Hdm is the product of the radiation time tdm and effective irradiance Edm.

Reduction can consist of:

- avoiding the critical wavelengths by using corresponding filters according to the spectral sensitivity of the irradiated object
- reducing the irradiance
- reducing the exposure time
- enlarging the distance to the luminaire

Remarks on filtering the critical wavelengths: Relative spectral sensitivity for most samples is not only very high in the ultraviolet range of irradiation, and also still fairly high in the visible range for many exhibits. This would mean that the short-wave visible range also has to be filtered. To what extent this is feasible depends on the colour rendering characteristics and the changed colour temperature of the remaining visible radiation.

9 Disposal of discharge lamps

High-pressure discharge lamps contain small quantities of mercury as an environment-relevant substance. Metal halide lamps can also contain thallium iodide as an additive. This is why discharge lamps must be disposed of separately from domestic waste and industrial waste similar to domestic waste. The last owner is obliged to dispose of the discharge lamp using the correct procedure.

Breakage of high-pressure discharge lamps emits traces of toxic mercury and thallium halides.

More information on handling discharge lamps is available at

<http://www.osram.com/weee>

In any case the legal regulations of the respective country have to be respected.

9.1 Statutory requirements

Directive 2002/96/EC WEEE (waste of electrical and electronic equipment) came into effect on 13 February 2003. It applies in all Member States of the European Union.

Similar systems are also in use in some non-European countries.

The main aim of this EU directive is the re-use, material recycling and other forms of recycling of such waste products in order to reduce the quantity of waste and to protect resources, particularly by means of reuse and recycling.

All manufacturers and importers of electrical and electronic equipment are obliged to take back their products and to ensure that they are treated, reused or recycled.

OSRAM lamps intended for recycling are marked with this symbol.



General information on disposal can be found at <http://www.osram.com/weee>

9.2 Collection, transport and disposal of discharge lamps at end-of-life

During transport to disposal or collection points, please make sure that the lamps are adequately protected from breakage, which would result in the emission of mercury.

Transport of the used discharge lamps by the last owner is not subject to transport permission. The lamps do not constitute dangerous cargo in accordance with the corresponding regulations GGVS, GGVE and ADR and RID.

9.3 Ordinance on Hazardous Substances

Discharge lamps (fluorescent lamps, compact fluorescent lamps, high-pressure mercury vapor lamps, metal halide lamps, high-pressure and low-pressure sodium vapor lamps) are not subject to mandatory marking according to the Ordinance on Hazardous Substances.

10 List of abbreviations

ACGIH	American Conference of Governmental Industrial Hygienists
AGLV	Arbeitsgemeinschaft Lampen-Verwertung (Lamp recycling consortium)
ANSI	American National Standards Institute
CE	Communauté Européenne (European Community)
CIE	Commission Internationale de l'Eclairage (International Lighting Commission)
DALI	Digital Addressable Lighting Interface (communications standard for lighting systems)
CISPR	Comité international spécial des perturbations radioélectriques (Special International Committee for Electromagnetic Interference)
ELMAPS	European lamp Manufacturers association for the preparation of standards
EMC	Electromagnetic Compatibility
EN	European standards
ENEC	European Norms Electrical Certification
ECG	electronic control gear
ICNIRP	International Commission on Non-Ionizing Radiation Protection
IEC	International Electro technical Commission
CCG	Conventional Control gear (choke)
LIF	Lighting Industry Federation Ltd
LSF	Lamp survival factor (as per standard EN 12464)
LLMF	Lamp luminous flux maintenance factor (as per standard EN 12464)
LMF	Luminaire Maintenance factor (as per standard EN 12464)
NIOSH	National Institute for Occupational Safety and Health
PCA	polycrystalline Alumina
RMF	Room Maintenance factor (as per standard EN 12464)
SCN	suprachiasmatic Nucleus
WEEE	Waste Electrical and Electronic Equipment
MF	Maintenance factor (as per standard EN 12464)
ZVEI	Zentralverband Elektrotechnik- und Elektronikindustrie e.V. (Central Federation of the Electrical and Electronic Industry)

11 Literature

- [1] Kelly, D. H. (1961) Visual Response to Time-Dependent Stimuli. I. Amplitude Sensitivity Measurements. JOURNAL OF THE OPTICAL SOCIETY OF AMERICA Vol. 51, Nr 4 On Pages: 422-429
Henger, U. (1986) Untersuchungen zur Entwicklung eines Messgerätes zur Bestimmung des Flickerfaktors. Licht 86 7. Lichttechnische Gemeinschaftstagung.
- [2] Afshar, F. 2006. Light Flicker-Factor as a Diagnostic Quantity for the Evaluation of Discharge Instabilities in HID Lamps. LEUKOS Vol. 3 No 1, July 2006
- [3] Sturm: „Betriebsgeräte und Schaltungen für elektrische Lampen“, Siemens AG Verlag

OSRAM AG

Head Office

Hellabrunner Strasse 1
81543 Munich
Germany
Phone +49 (0)89-6213-0
Fax +49 (0)89-6213-20 20
www.osram.com

