

# **SYLVANIA**

**FM Miniature Fluorescent Lamps**

**Technical Data  
and  
Application Notes**



**Sylvania  
Lighting  
International**





## SYLVANIA

### FM Miniature Fluorescent Lamps

#### Technical Data and Application Notes

#### TABLE OF CONTENTS

	page
1. Product Description	2
2. The Cap / Holder System	3
3. Lamp Ballasts	4
4. The Effect of Temperature on Lamp Properties	9
5. Spectral Properties	10

#### **IMPORTANT NOTE**

These APPLICATION NOTES contain information which has been developed to assist the designer and manufacturer of ballasts for MINIATURE FLUORESCENT LAMPS in the development of a safe and compatible product.

SYLVANIA LIGHTING INTERNATIONAL or its subsidiaries assume no responsibility for the performance and safety of such ballasts. The sole responsibility for ballast design lies with the ballast manufacturer.



## 1. PRODUCT DESCRIPTION

SYLVANIA Miniature Fluorescent Lamps Type FM belong to the family of double-ended fluorescent lamps. They are characterized by the small bulb diameter of 7 mm (T2) and the special cap. Construction and principle of operation are comparable to 15 or 26 mm  $\varnothing$  (T5 or T8) lamps. Following is a summary of the relevant lamp data:

Lamp wattage:	6, 8, 11, 13 W
Lamp colour:	Warm white DELUXE 183 - 830 Cool white DELUXE 184-840 (other triphosphor colours in preparation)
Colour temperature:	3000 K (WWX) ; 4000 K (CWX)
Colour rendition:	Class 1B
Lamp length:	218 - 523 mm
Luminous flux:	310 - 860 lm
Luminous efficacy:	52 - 67 lm / W
Average life:	8000 h
Operating system:	electronic ballast with current-controlled preheating and safety shut-off
Cap- / holder system:	W 4.3

See attached lamp data sheets for further technical information.

The compact design of SYLVANIA FM lamps leads to many different applications, such as

- desk lamps, furniture lighting
- lighting of paintings or other objects
- exit signs and display lighting
- emergency lighting
- in battery-operated luminaires in vehicles, for camping and other leisure applications
- in avionic and automotive instrumentation
- for backlighting or edge lighting of LCD's
- for light boxes
- for shop counters and displays

## 2. THE CAP / HOLDER SYSTEM

During the development phase of the FM lamp, SYLVANIA engineers had to create a new cap which is compatible with the small lamp diameter: cap type **W 4.3 x 8.5 d** (**abbreviated designation: W 4.3**).

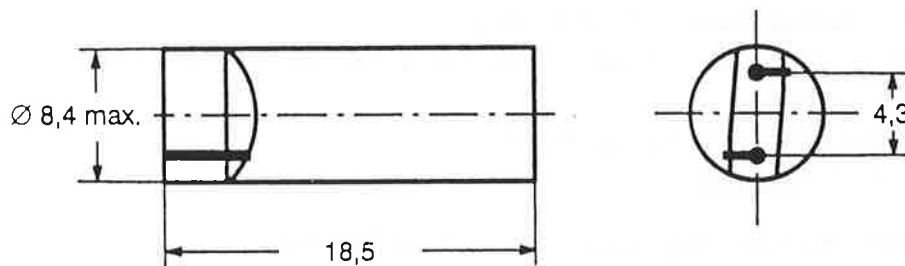

The cap material is greyish-white moulded plastic (ULTEM 1000) with 120 °C temperature resistance. The cylindrical part has a maximum diameter of 8.4 mm. The lead wires (material: Ni-Fe) are fixed in a slot to avoid displacement during lamp insertion. The contact faces are slightly tapered to ensure parallel seating of both lamp caps after insertion into the lampholder. The caps are mechanically fixed to the lamp press seal. The maximum **radial misalignment** end to end is **3 degrees**.

Lampholders for FM lamps are available for **lateral** as well as for **axial** lamp insertion. A listing of component suppliers is available upon request.

The **maximum cap temperature** has been specified to 100 °C, measured at a distance of 16.5 mm from the face of the lamp cap. The lampholder material should be **UV- and temperature resistant**.

Standardisation proposals for lamps and holders have been submitted to the respective IEC working groups. Approval testing for lampholders is possible, as integral part of a luminaire, based on the requirements of IEC 400 / EN 60400.



### 3. LAMP BALLASTS

#### 3.1 General Requirements

Due to the high lamp operating voltage and to optimize lamp operating conditions in luminaires, FM lamps are specifically designed for operation with **electronic ballasts with current-controlled preheated starting**. This leads to the following advantages for the user:

- flicker-free start and lamp operation
- low fixture heating by reduced ballast losses
- compact and light-weight ballast design
- elimination of starter and starter holder as additional components
- dimming capability
- safe operation at the end of lamp life
- AC and DC operation.

Following is a summary of lamp data as guidance for ballast design:

Lamp Type	FM 6 W	FM 8 W	FM 11 W	FM 13 W
Lamp wattage (W)	5.0	7.8	10.8	13.3
Lamp voltage ( $V_{eff}$ )	51	79	110	136
Lamp current ( $mA_{eff}$ )	100	100	100	100
Lamp power factor	0.98	0.98	0.98	0.98

#### Open Circuit Voltage

during preheat min. ( $V_{eff}$ )	225	250	275	300
for ignition min. ( $V_s$ )	500	525	550	575

#### Reference Ballast (f = 25 KHz)

Impedance ( $\Omega$ )	1690	1410	1670	1740
Input voltage (V)	220	220	277	310

#### Cathode Heating Voltage / Lead Current

	MIN.	MAX.	applies to all lamp wattages
Cathode heating voltage (V)		3	
Lead current during stable operation (mA)		150	
Preheat current at preheat time < 0.4 s (mA)	179	200	
= 0.75 s (mA)	143	175	
= 1 s (mA)	131	165	
= 1.5 s (mA)	118	155	
> 2.0 s (mA)	110	150	

All data refer to lamp operation at **f = 25 Khz**, after 100 h aging.

To achieve specified lamp life the lamp current crest factor (CCF) must be  $\leq 1.7$ .

Test circuit D on page 8 is used for the measurement of photometric and electrical lamp data. The lamp must be stable at the time of measurement.



### 3.2 Ballast Requirements for Abnormal Lamp Operating Conditions

Electronic ballasts for FM lamps must be designed in accordance with the requirements of Publications **IEC 928 / EN 60 928** (safety) and **IEC 929 / EN 60929** (performance), respectively.

Those operating modes of FM lamps which are known to occur under end-of-life conditions, are described below. Test circuits are specified, wherever this is feasible. It should be mentioned, however, that such test circuits cannot fully reproduce the conditions prevailing in an electrical low pressure discharge. It is therefore suggested that, in addition to the ballast type tests described below, extended **system life testing** (ballast & lamp), be conducted to ensure safe performance.

Low pressure discharge lamps, especially those with smaller tube diameter may exhibit **increased energy dissipation** in the vicinity of the cathodes, which are positioned in close proximity to the inner bulb wall. Caused by an **increase in lamp voltage** - resulting from higher cathode fall - or **excessive current flow** through the lead wires, **local overheating of the bulb** may occur. This, in turn, may lead to melting or breaking of the glass.

To avoid **safety risks** from the processes described above, such as damage from hot glass particles, exposure to mercury released from the lamp or to live conducting parts (electrodes, leadwires) after glass breakage, **the ballast must be capable of recognizing these conditions and subsequently switch off the lamp.**

Unfortunately, there is not one single electrical lamp parameter (lamp current, wattage or voltage) which may be used by a ballast designer to monitor changes in lamp performance for the purpose of initiating a system switch off.

To ensure safe operation, **a ballast must be subjected to and meet all of the conditions listed below.** For those conditions which refer to abnormal lamp operation, **the ballast must shut off within five seconds**, if one or more of these conditions occur simultaneously.

It should be pointed out that

- the following requirements apply to **electronic ballasts with current-controlled preheated starting, only**
- **conventional (magnetic) ballasts are not suitable for operation of FM lamps.**

### 3.3 Test Requirements

#### 3.3.1 **Safety during lamp insertion (protection against accidental contact):**

- **The lamp is not inserted, or only one cap is inserted**  
Safety of the ballast must not be impaired if the lamp is not inserted.
- If only **one cap is inserted**, the "live part" requirements of IEC 598 / EN 60598, App. B(1) and B(2) apply:
- max. current between (accessible) lamp leads and ground < 0.7 mA (peak).  
Resistance: 2 K $\Omega$ ;
- Max voltage between (accessible) lamp leads and ground < 34 V (peak).  
Resistance: 50 K $\Omega$ ;

For compliance testing an electronic ballast is used.

#### 3.3.2 **The lamp does not start, both cathodes are functional:**

Potential causes: de-activated cathode, low cathode resistance, or no discharge possible.

- Permanent preheating of cathodes is possible in this case. The ballast must shut off after the respective preheat time which is specified as a function of preheat current, s. test circuit A, page 8. Substitution resistors ( $R = 70 \Omega$ ) may be used instead of a lamp.

#### 3.3.3 **The lamp does not start, one or both cathodes are interrupted:**

- Test circuit B, page 8. The cathode interruption is simulated by sequentially interrupting each current lead. In each case the ballast must shut off within 5 s.

#### 3.3.4 **The lamp operates, but exhibits differences in cathode emission (rectification):**

- This condition is simulated with test circuit C, page 8, which is equivalent to that of IEC 928 / EN 60928, Fig. 1. The diode specification is also listed there.

R1 and R2 correspond to the hot resistance of one cathode ( $R1 = R2 = 70 \Omega$  for all lamp types). It is recommended to use potentiometers with marked center position. This facilitates handling of the left / right setting.  $R3 = 5 \text{ k}\Omega$ .

S2 is closed when the lamp is operating stable (after 10 - 15 min.)

The ballast must shut off within 5 s with any position of R1, R2 and S1, if the **power dissipated in R3 exceeds the critical value of 4 W**. The resistance of R3 is increased in 10 steps of approx.  $0.3 R_{\text{lamp}} \Omega$ . After each step the lamp must be stabilised for at least 1 min.



**3.3.5 Lamp voltage exceeds maximum value:**

- Lamp voltage usually increases with progressing lamp operating time. The ballast must be designed such that the lamp is switched off within five seconds when the lamp voltage exceeds the maximum specified value:

Lamp Type	Maximum Lamp voltage (V)	Lamp Resistance ( $\Omega$ )
FM 6 W	75	510
FM 8 W	110	790
FM 11 W	145	1100
FM 13 W	180	1360

Test circuit C, page 8. S2 is open, R3 is increased from 0  $\Omega$  until the specified maximum lamp voltage is reached. The limiting value may be exceeded if lamp current and voltage are reduced such that the lamp is operated at rated wattage. In this case the cathode voltage must be  $\leq 7.5$  V and the wattage dissipated in the cathode  $\leq 0.7$  W, respectively.

**3.3.6 The maximum current in any lead is exceeded during stable operation:**

- During testing according to 3.3.5 the ballast must shut off in  $< 5$  s if the current in any lead exceeds the limiting value of 150 mA.

### SHUT OFF REQUIREMENTS

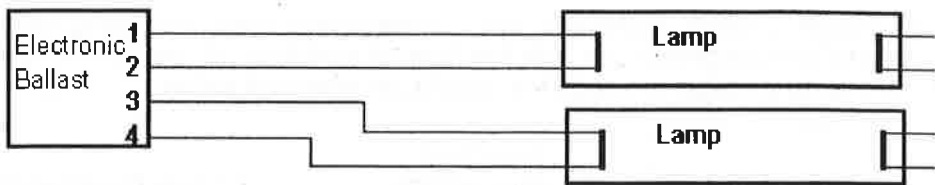

**Test circuit A** Lamp does not start, cathode not broken

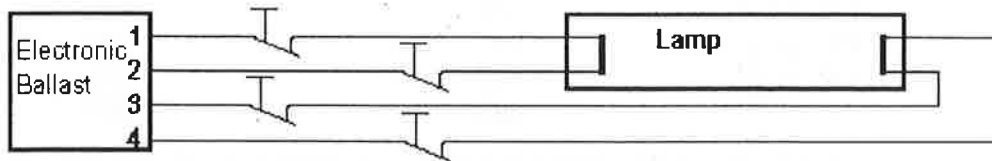

**Test circuit B** Lamp start with broken cathode

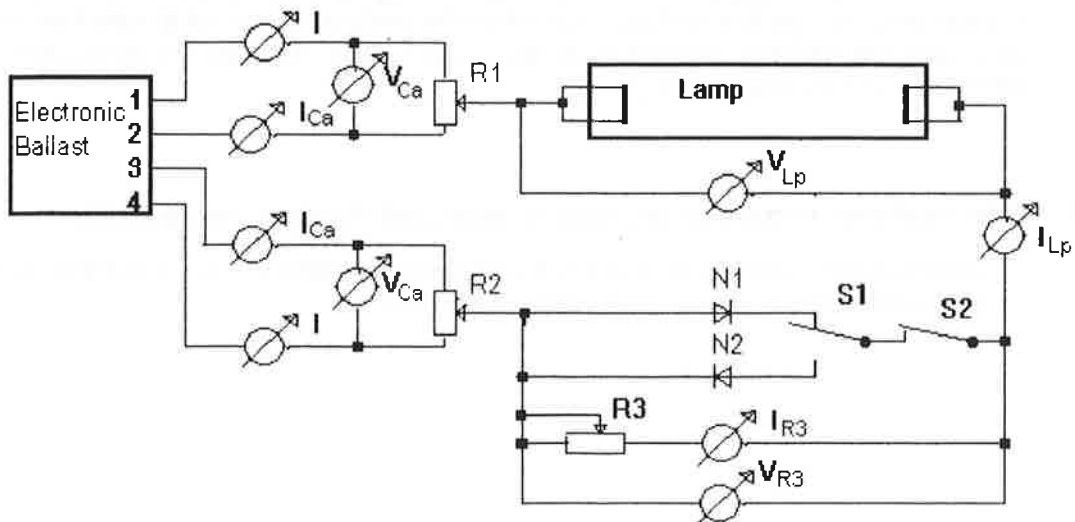

**Test circuit C** Asymmetrical emission of cathodes, max. lamp voltage, max. lead current

### LAMP TEST

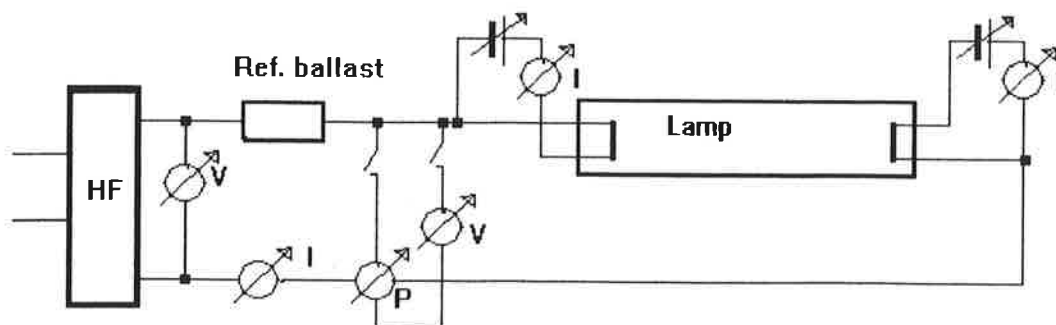

**Test circuit D** Photometrical and electrical tests

#### 4. THE EFFECT OF TEMPERATURE ON LAMP PROPERTIES

Similar to all other fluorescent lamps the properties of FM lamps are also temperature dependant:

Fig. 1 shows the temperature dependance of the colour temperature, Fig. 2 the luminous flux of an FM lamp as a function of temperature.

The **maximum light output** occurs near room temperature. The shape of the curve is similar to that of LYNX compact fluorescent lamps with comparable wattage.

For practical applications, a reference temperature which reflects the operating conditions of a lamp inside a luminaire must be defined. The minimum lamp ambient temperature which is specified in the lamp data sheets refers to the **lamp starting behaviour**, the maximum value corresponds to the ambient conditions at which **lumen depreciation is still < 30 %**.

Instead of ambient temperature it is also possible to measure the bulb center temperature. Measurements should be conducted with lamps operated horizontally, after stabilisation.

Fig. 3 shows the relationship between bulb and ambient temperature.

A typical temperature distribution of a stabilised, free burning FM 13 W lamp is shown in Fig. 4.



## 5. SPECTRAL PROPERTIES

For the production of FM lamps the best, presently available phosphors, so-called "triphosphor" components, are used. These yield high colour rendition and good lumen maintenance.

Like all fluorescent lamps, FM lamps also emit small amounts of UV-radiation. For example, the UV energy (315 - 400 nm) measured at a distance of  $d = 100$  mm of an FM 13 W / 183 lamp is

**2.26 microwatts per  $\text{cm}^2$ .**

For luminaire design, it is recommended to use only UV-resistant materials (e. g. LEXAN 943 or 953 R).

If luminaires without cover are used for the illumination of light-sensitive objects, the same precautions as for other light sources apply. The UV emission of FM lamps is approx.

**60 - 80 microwatts per lumen**

and thus comparable to incandescent lamps.

This relatively small UV emission has no effect on the user of FM lamps, if lamps are used in accordance with the relevant specifications. The erythral dose from FM lamps is only  $1/15^{\text{th}}$  of the erythral threshold value of  $250 \text{ Wsec/m}^2$ , measured at  $1000 \text{ lx}$  per 8 h.

**Fig.1 Colour Temperature vs. Ambient (FM 11W)**

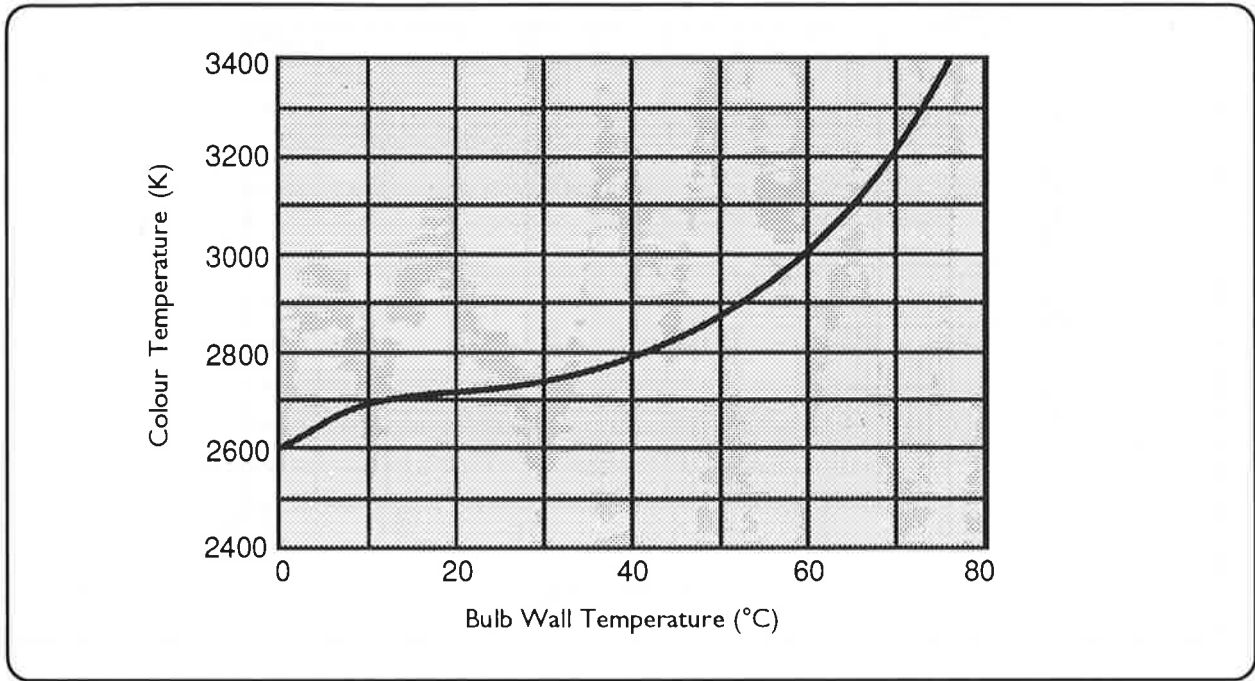

**Fig.2 Luminous Flux vs. Ambient (FM 11W)**

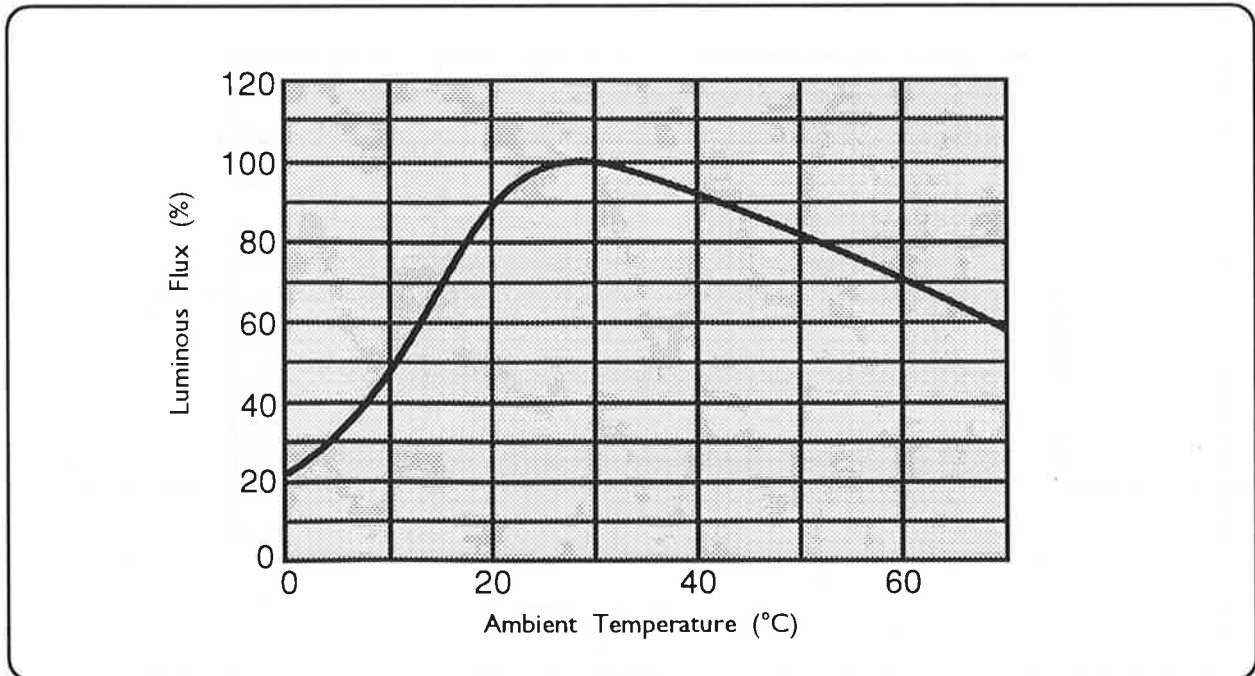

**Fig.3 Center Bulb Wall Temperature vs. Ambient (FM13 W)**

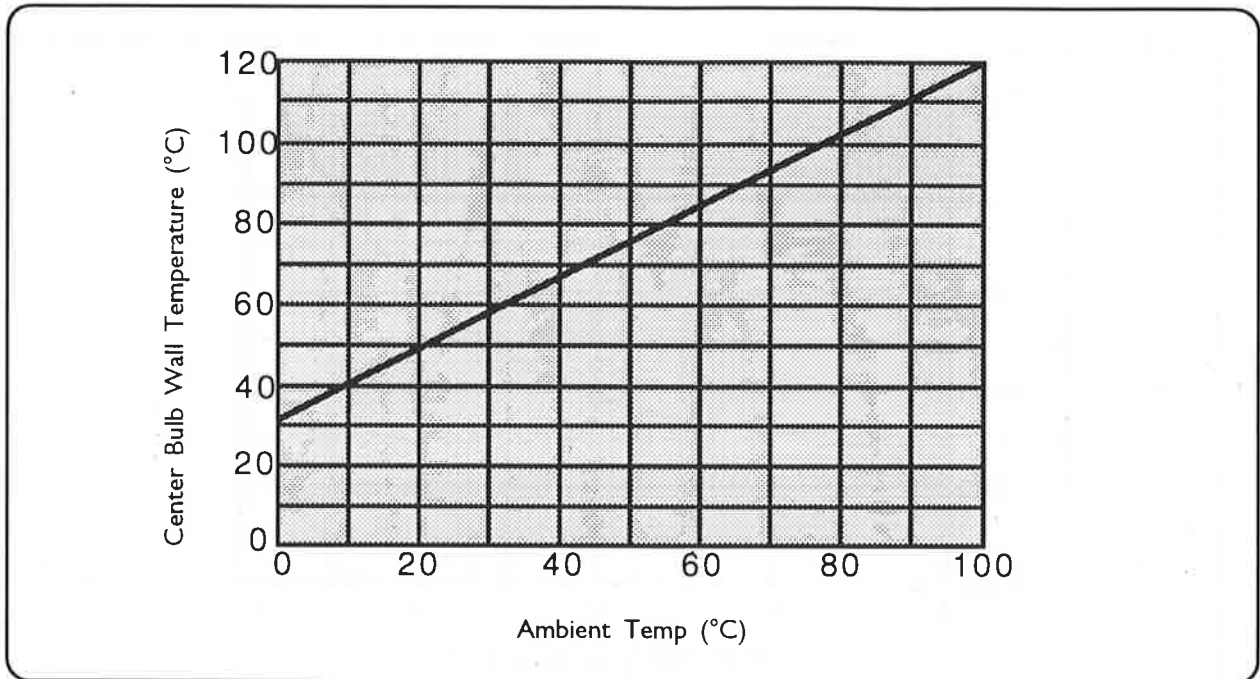

**Fig.4 Temperature Distribution (FM 13W)**

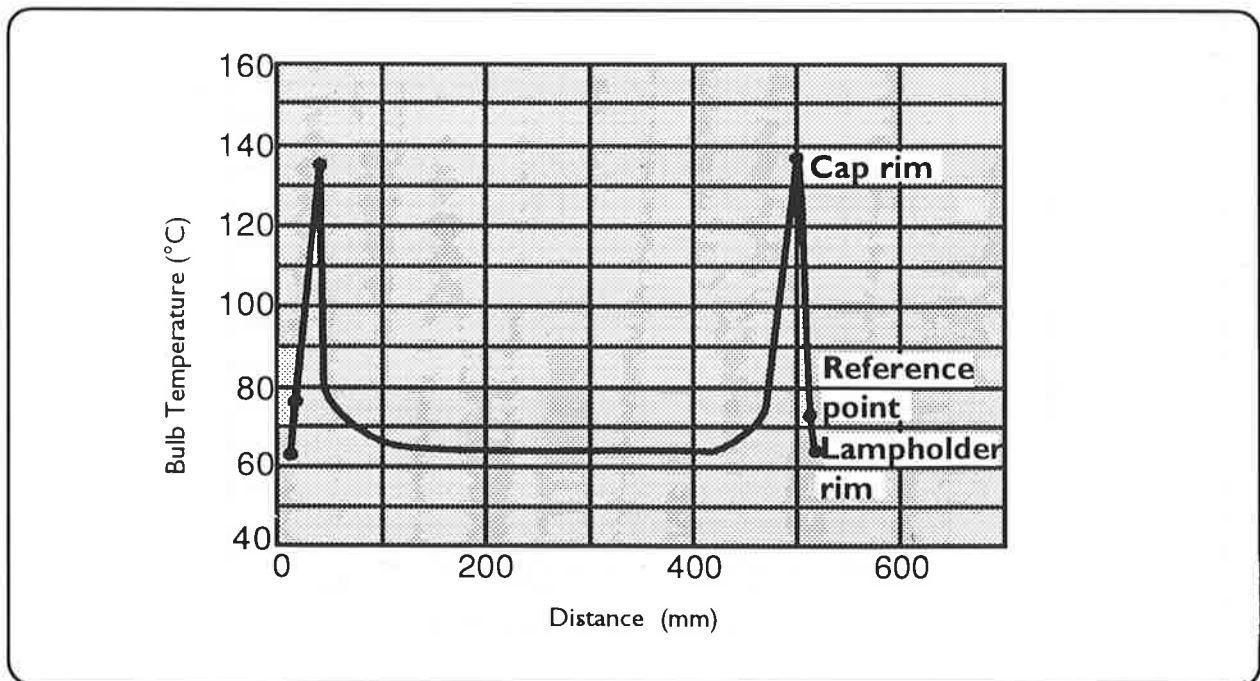



# MINIATUR FLUORESCENT LAMP T2

## FM 6W

### HF-Operation



#### OUTLINE:

Norminal dimension: 7x220

Dimensions in mm

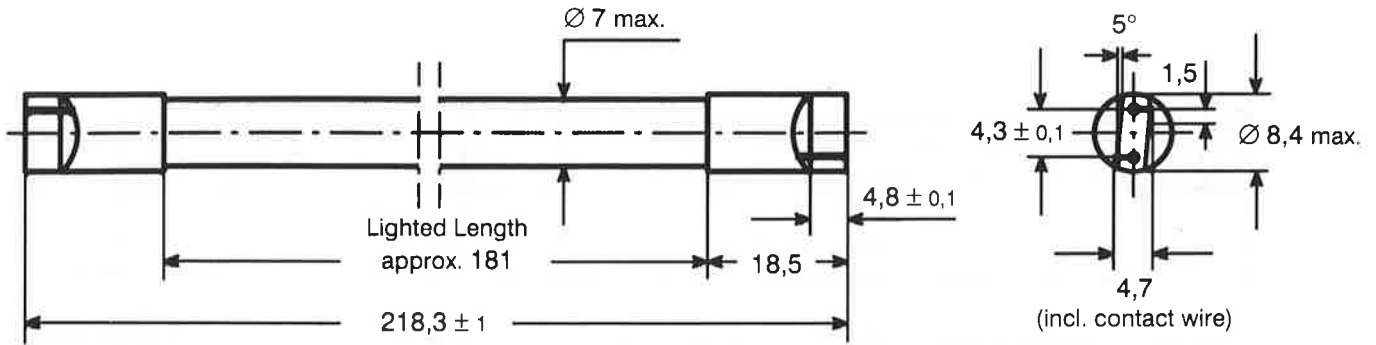

Cap: W4.3x8.5d

max. bow: 1.1 mm

max. radial misalignment:  $3^\circ$

<u>ELECTRICAL DATA</u>		:	<u>Nominal value</u>	<u>min.</u>	<u>max.</u>
Frequency	(kHz) :			20	
Lamp wattage	(W) :		5,0		
Lamp operating voltage	(V) :		51	46	56
Lamp current	(mA) :		100	90	110
Current crest factor	:				1,7
Cathode voltage	(V) :		3,0		
<u>Current controlled preheating:</u>					
Preheat current	at >2s	(mA) :		110	150
	at <0,4s	(mA) :		179	200
Electrode substitution resistor	( $\Omega$ ) :		70	63	
Open circuit voltage	(V) :			225	

<u>OPERATING CONDITIONS</u>		:	
Ballast type (Reference data)	:		Electronic 25 kHz (1690 $\Omega$ /220V)
Average life (50% failure rate)	(h) :		8000
Individual life	(h) :		2000
Lamp ambient temperature	( $^\circ\text{C}$ ) :		-15
Cap temperature	( $^\circ\text{C}$ ) :		100
Burning position	:		any

#### PHOTOMETRIC DATA:

Colour	Code	* Luminous Flux		CRI	Colour Temperature	ILCOS Code
		nom. (lm)	min. (lm)			
warm white DELUXE	183-830	310	295	1B	3000	FDH-6/30/1B-L/P-W4.3x8.5-7/220
** cool white DELUXE	184-840					

\* measured with HF-reference ballast at 25  $^\circ\text{C}$ , after 100h aging. Lamp stabilized.

\*\* after Inquiry.

APPLICATION: Indoor and outdoor lighting

ATTENTION: The lamp must be operated with an electronic ballast with current-controlled preheating. The ballast must be comply with EN 60929 and EN 60928. For additional requirements see "SYLVANIA FM MINIATURE FLUORESCENT LAMPS, technical data and application notes", most recent issue. Standardisation proposals for lamps (EN 60081) and holders (EN 60061) have been submitted.

Issued by : ERLANGEN  
 Date : 03.03.1992  
 Revision date: 15.03.1995

## DATA SHEET

Specification No. 5181 E  
 Supersedes : 5181 D 22.10.93  
 Page 1 of 1



# MINIATUR FLUORESCENT LAMP T2

## FM 8W

### HF-Operation



#### OUTLINE:

Norminal dimension: 7x320

Dimensions in mm

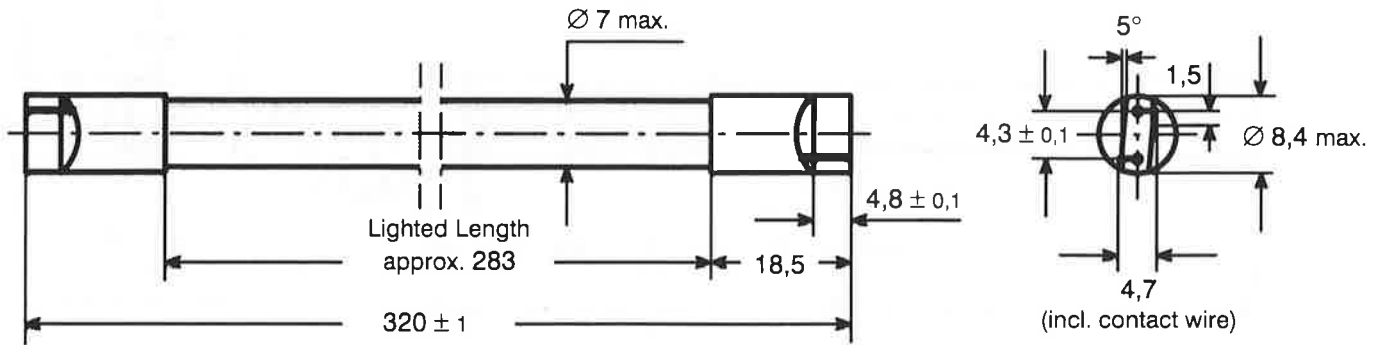

Cap: W4.3x8.5d

max. bow: 1.4 mm

max. radial misalignment:  $3^\circ$

ELECTRICAL DATA		Nominal value	min.	max.
Frequency	(kHz) :		20	
Lamp wattage	(W) :	7,8		
Lamp operating voltage	(V) :	79	71	87
Lamp current	(mA) :	100	90	110
Current crest factor	:			1,7
Cathode voltage	(V) :	3,0		
<u>Current controlled preheating:</u>				
Preheat current	at >2s (mA) :		110	150
	at <0,4s (mA) :		179	200
Electrode substitution resistor	( $\Omega$ ) :	70	63	
Open circuit voltage	(V) :		250	

OPERATING CONDITIONS				
Ballast type (Reference data)	:	Electronic 25 kHz (1410 $\Omega$ /220V)		
Average life (50% failure rate)	(h) :	8000		
Individual life	(h) :		2000	
Lamp ambient temperature	( $^\circ$ C) :		-15	60
Cap temperature	( $^\circ$ C) :			100
Burning position	:	any		

#### PHOTOMETRIC DATA:

Colour	Code	* Luminous Flux		CRI	Colour Temperature	ILCOS Code
		nom. (lm)	min. (lm)			
warm white DELUXE	183-830	500	475	1B	3000	FDH-8/30/1B-L/P-W4.3x8.5-7/320
cool white DELUXE	184-840	500	475	1B	4000	FDH-8/40/1B-L/P-W4.3x8.5-7/320

\* measured with HF-reference ballast at 25  $^\circ$ C, after 100h aging. Lamp stabilized.

**APPLICATION:** Indoor and outdoor lighting

**ATTENTION:** The lamp must be operated with an electronic ballast with current-controlled preheating. The ballast must be comply with EN 60929 and EN 60928. For additional requirements see "SYLVANIA FM MINIATURE FLUORESCENT LAMPS, technical data and application notes", most recent issue. Standardisation proposals for lamps (EN 60081) and holders (EN 60061) have been submitted.

Issued by : ERLANGEN  
Date : 03.03.1992  
Revision date: 15.03.1995

## DATA SHEET

Spezifikation No. 5163 E  
Supersedes : 5163 D 22.10.93  
Page 1 of 1



# MINIATUR FLUORESCENT LAMP T2

**FM 11W**  
HF-Operation



**OUTLINE:**

Norminal dimension: 7x420

Dimensions in mm

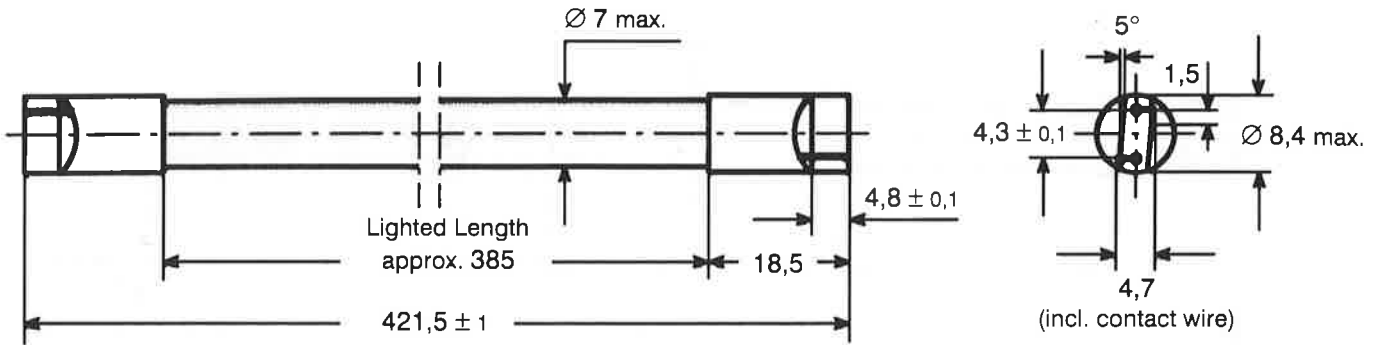

Cap: W4.3x8.5d

max. bow: 1.7 mm

max. radial misalignment: 3°

<b>ELECTRICAL DATA</b>		Nominal value	min.	max.
Frequency	(kHz) :		20	
Lamp wattage	(W) :	10,8		
Lamp operating voltage	(V) :	110	100	120
Lamp current	(mA) :	100	90	110
Current crest factor	:			1,7
Cathode voltage	(V) :	3,0		
<b>Current controlled preheating:</b>				
Preheat current	at >2s (mA) :		110	150
	at <0,4s (mA) :		179	200
Electrode substitution resistor	(Ω) :	70	63	
Open circuit voltage	(V) :		275	

<b>OPERATING CONDITIONS</b>				
Ballast type (Reference data)	:	Electronic 25 kHz (1670Ω/277V)		
Average life (50% fallure rate)	(h) :	8000		
Individual life	(h) :		2000	
Lamp ambient temperature	(°C) :		-15	60
Cap temperature	(°C) :			100
Burning position	:	any		

**PHOTOMETRIC DATA:**

Colour	Code	* Luminous Flux		CRI (Class)	Colour Temperature (K)	ILCOS Code
		nom. (lm)	min. (lm)			
warm white DELUXE	183-830	680	646	1B	3000	FDH-11/30/1B-L/P-W4.3x8.5-7/420
cool white DELUXE	184-840	680	646	1B	4000	FDH-11/40/1B-L/P-W4.3x8.5-7/420

\* measured with HF-reference ballast at 25 °C, after 100h aging. Lamp stabilized.

**APPLICATION:** Indoor and outdoor lighting

**ATTENTION:** The lamp must be operated with an electronic ballast with current-controlled preheating. The ballast must be comply with EN 60929 and EN 60928. For additional requirements see "SYLVANIA FM MINIATURE FLUORESCENT LAMPS, technical data and application notes", most recent issue. Standardisation proposals for lamps (EN 60081) and holders (EN 60061) have been submitted.

Issued by : ERLANGEN  
Date : 03.03.1992  
Revision date: 15.03.1995

**DATA SHEET**

Specification No. 5167 E  
Supersedes : 5167 D 22.10.93  
Page 1 of 1



# MINIATUR FLUORESCENT LAMP T2

## FM 13W

### HF-Operation



#### OUTLINE:

Norminal dimension: 7x520

Dimensions in mm

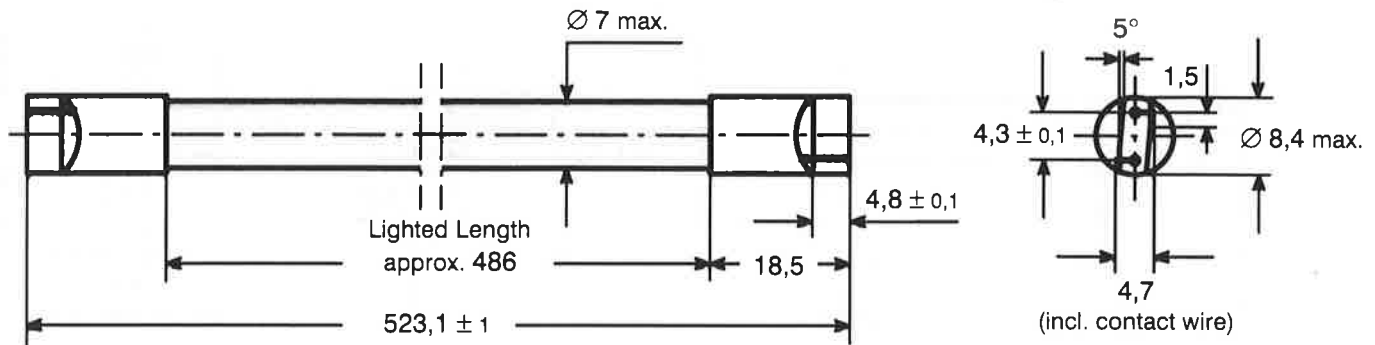

Cap: W4.3x8.5d

max. bow: 2.0 mm

max. radial misalignment:  $3^\circ$

#### ELECTRICAL DATA

		Nominal value	min.	max.
Frequency	(kHz) :		20	
Lamp wattage	(W) :	13,3		
Lamp operating voltage	(V) :	136	122	150
Lamp current	(mA) :	100	90	110
Current crest factor	:			1,7
Cathode voltage	(V) :	3,0		
<b>Current controlled preheating:</b>				
Preheat current	at $>2s$ (mA) :		110	150
	at $<0,4s$ (mA) :		179	200
Electrode substitution resistor	( $\Omega$ ) :	70	63	
Open circuit voltage	(V) :		300	

#### OPERATING CONDITIONS

Ballast type (Reference data)	:	Electronic 25 kHz (1740 $\Omega$ /310V)
Average life (50% failure rate)	(h) :	8000
Individual life	(h) :	2000
Lamp ambient temperature	( $^\circ C$ ) :	-15
Cap temperature	( $^\circ C$ ) :	100
Burning position	:	any

#### PHOTOMETRIC DATA:

Colour	Code	* Luminous Flux		CRI (Class)	Colour Temperature (K)	ILCOS Code
		nom. (lm)	min. (lm)			
warm white DELUXE	183-830	860	817	1B	3000	FDH-13/30/1B-L/P-W4.3x8.5-7/520
cool white DELUXE	184-840	860	817	1B	4000	FDH-13/40/1B-L/P-W4.3x8.5-7/520

\* measured with HF-reference ballast at 25  $^\circ C$ , after 100h aging. Lamp stabilized.

**APPLICATION:** Indoor and outdoor lighting

**ATTENTION:** The lamp must be operated with an electronic ballast with current-controlled preheating. The ballast must be comply with EN 60929 and EN 60928. For additional requirements see "SYLVANIA FM MINIATURE FLUORESCENT LAMPS, technical data and application notes", most recent issue. Standardisation proposals for lamps (EN 60081) and holders (EN 60061) have been submitted.

Issued by : ERLANGEN  
 Date : 03.03.1992  
 Revision date: 15.03.1995

## DATA SHEET

Specification No. 5171 E  
 Supersedes : 5171 D 22.10.93  
 Page 1 of 1



