

HSI-M-TD 150W/WDL

Metal Halide Lamps

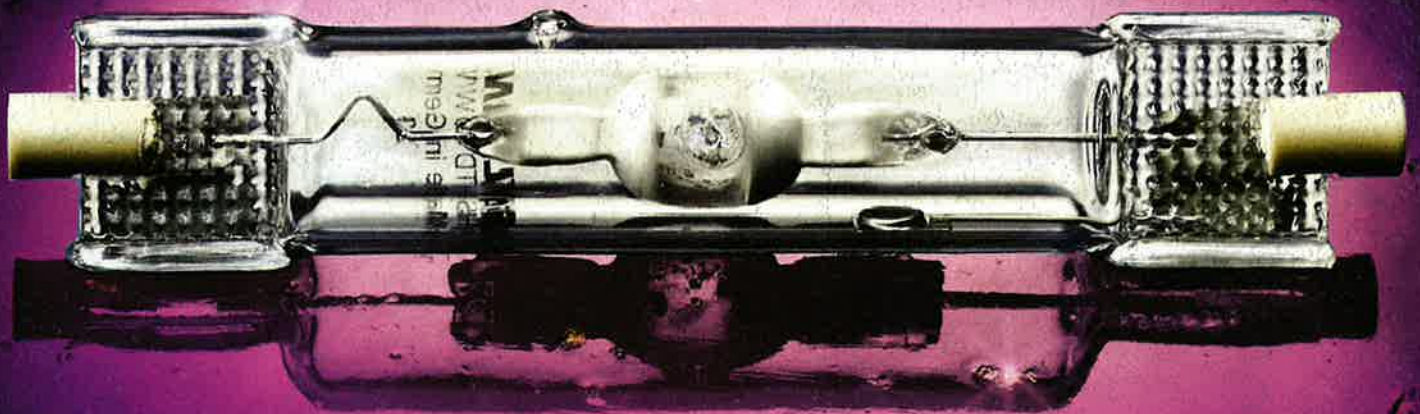

Technical Manual

SYLVANIA

GTE

GTE Sylvania S.A.
20, route de Pré-Bois, P.O. Box 554
1215 Geneva 15 (Switzerland)
Tel. 022/798 21 61. Telex 415 565 (GTE CH)
Telefax 022/798 68 63, Cable INTELGENT

Sylvania reserves the right to change data and specifications without notice. Data for guidance only.

SYLVANIA **GTE**

Technical Manual HSI-M-TD 150W/WDL

This manual contains the following information :

1. Product description and data	2
2. Photometric/Colorimetric performance	5
3. Operating principles of metal halide lamps	7
4. Electrical parameters, equipment and lamp testing	9
- Ignition	9
- Warm up characteristics	12
- Mains voltage variation influence	13
- Lamp voltage variation influence	14
- Mains voltage harmonics	14
- 3 phase systems failure/resonances	14
- Ignitors, chokes	15
- Power factor correction	20
- Radio interference suppression	20
- Dimming	20
- Lamp testing, electrical, photometric, colorimetric data	21
5. Utilisation and application	23
- Lamp handling	23
- Operating position	23
- Radiation and colour fading	24
- Horticultural applications	27
- Exposure times	28
6. Recommendation for fixture design	29
- Thermal considerations	29
- Bulb temperature measurement	30
- Lamp holders	32
- Reflector	32
- Front glass requirements	33
7. Trouble shooting	34

1. Product Description and Data

Product designation	HSI-M-TD 150W/WDL
Lamp wattage	150 W \pm 30W
Circuit wattage	appr. 176 W
Lamp voltage	95 V \pm 10 V
Lamp current	1.8 A
Peak starting voltage (min...max)	4 - 4.5 kV
Pulse width at 90 % peak	2 μ sec
Pulse rate	min. 1/half cycle
Minimum starting temperature	- 35 °C
Run-up time for 90 % light output	3 min
Light output (100 h)	nom. 13.000 lm min. 11.700 lm
Efficacy	nom 87 lm/W
Efficacy with choke	appr. 74 lm/W
Colour temperature	3200 K \pm 300 K
Colour rendering	Class 2a
Arc length	18 mm
Average luminance	1500 cd/cm ²
Maximum luminance	3375 cd/cm ²
Lamp life average	6000h
Switch cycle for life test	11.5 h ON 0.5 h OFF
Operating position	Horizontal \pm 45 °
Recommended ambient lamp temperature	150 °C
Outer bulb temperature	max. 650 °C
Pinch seal temperature	max. 280 ° C
Lamp caps	RX7s-24
Outer bulb	Quartz glass, clear

Recommended operating data

Mains voltage variation	\pm 5 %
Choke current tolerance	\pm 3 %

All data are at 100 h. Measurements are taken in horizontal position with the tip-off of the arc tube **sideways** in the specified test fixture.

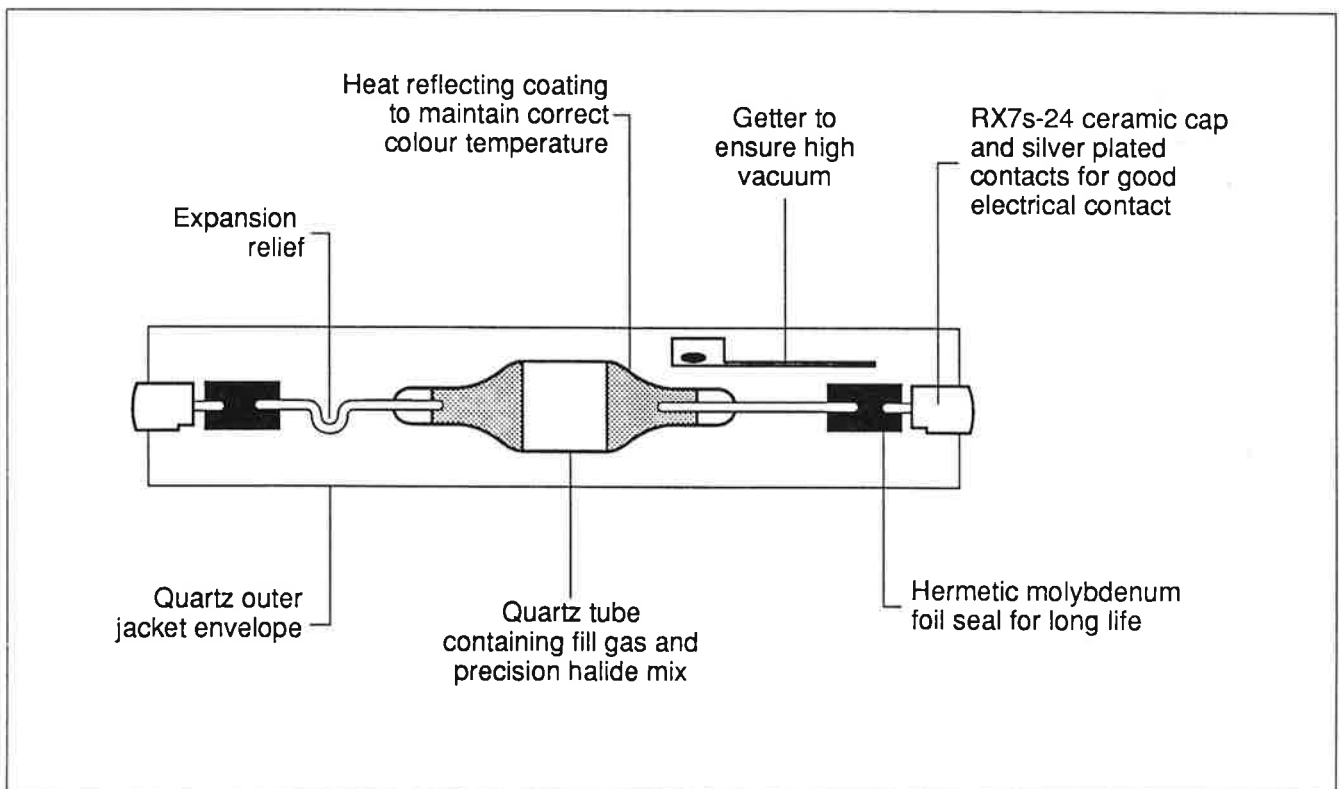
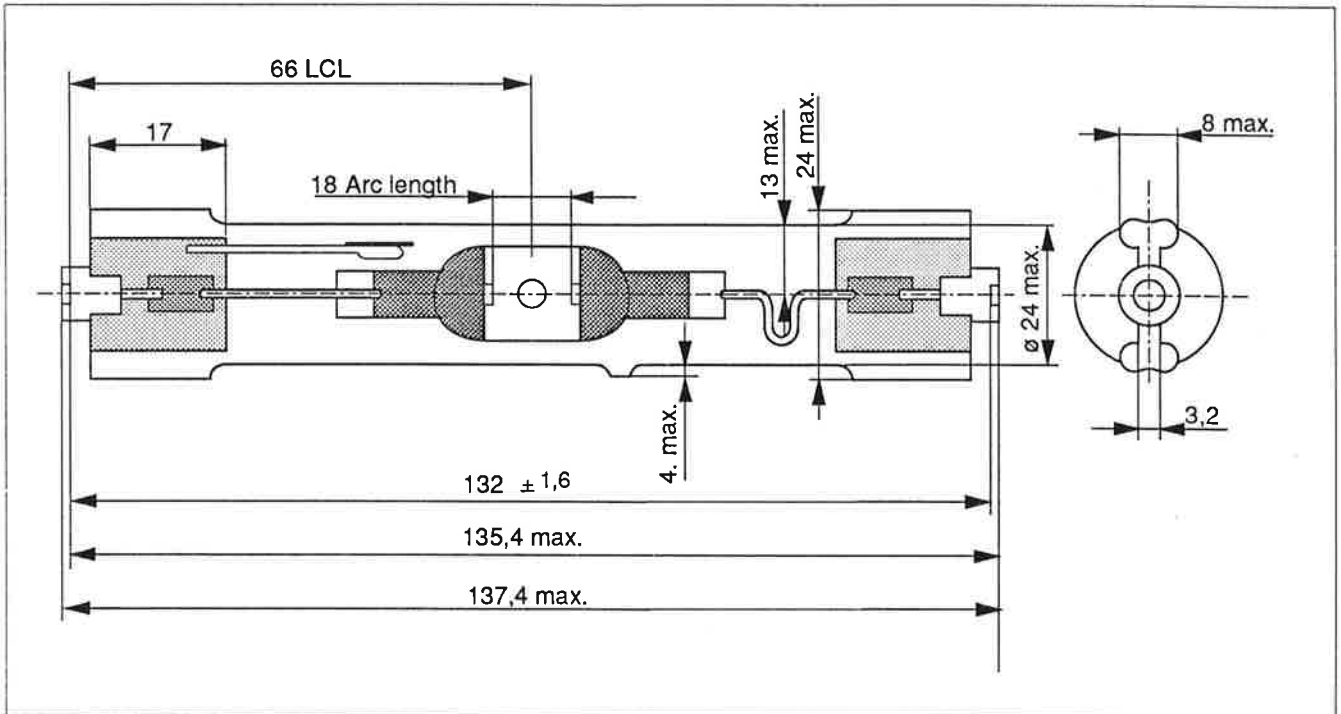

Physical characteristics

<i>Material</i>	<i>Function</i>	<i>Property</i>
Quartz glass	Arc tube Outer jacket	Transparent Refractory Strength Chemical stability
Tungsten	Electrode	Electron emission High melting point Low evaporation rate Chemical stability
Molybdenum	Seals Lead Wires	High melting point Ductile Electrically conductive Chemical stability Strength

2. Photometric and Colorimetric Performance (over life)

The following diagrams are valid for lamps operated to specified mains voltage and choketolerance, as well as in a fixture which corresponds to the established recommendations.

1. The light output performance is as follows :

- nom. lumen 13.000 (100 h)
- min. lumen 11.700 (100 h)
- mean lumen at 4000 hours appr. 7800 lm

2. The colour temperature under above conditions at 100 hours is

- nom. 3200 K
- tolerance ± 300 K
- colour shift during life + 100 K to + 400 K

If colour uniformity is important for an installation, it is recommended to group-replace lamps. For colour uniformity it is also important to consider the colours as used in a room (reflective surfaces) which may cause appearance differences for which the light source is not responsible.

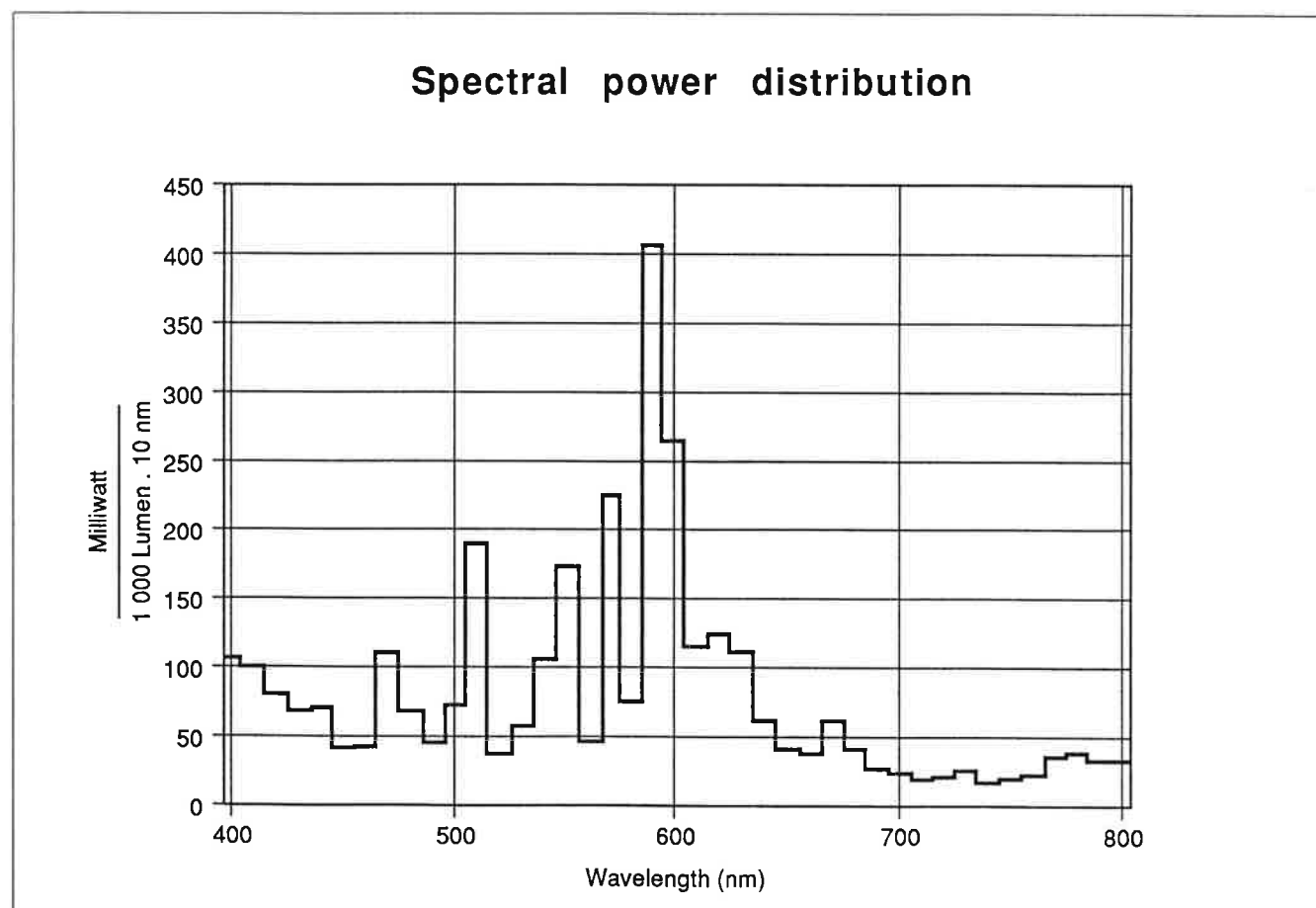

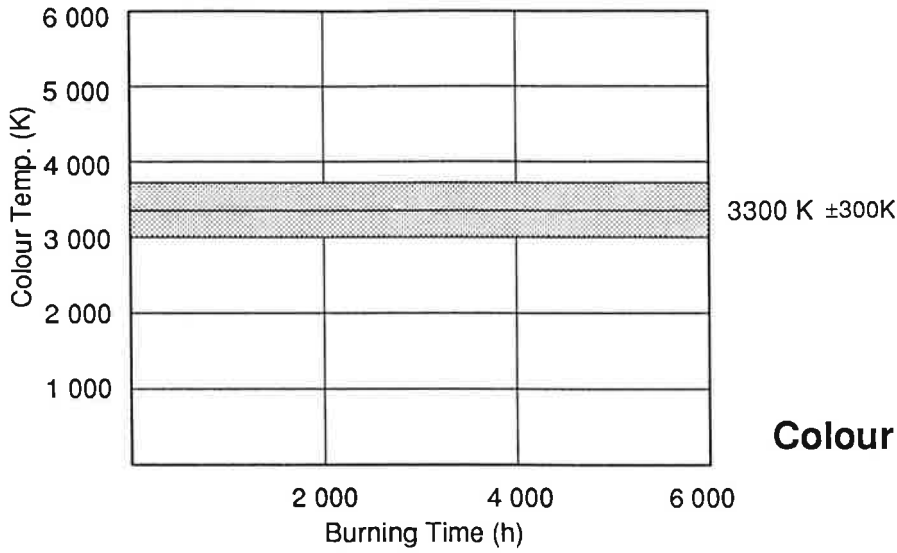

Colour maintenance

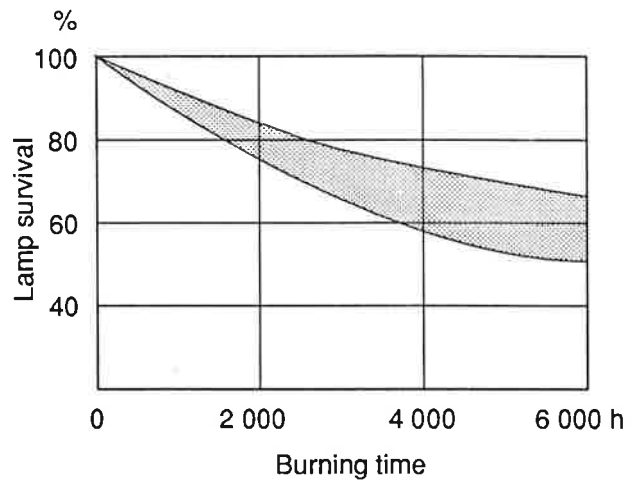

Lumen maintenance

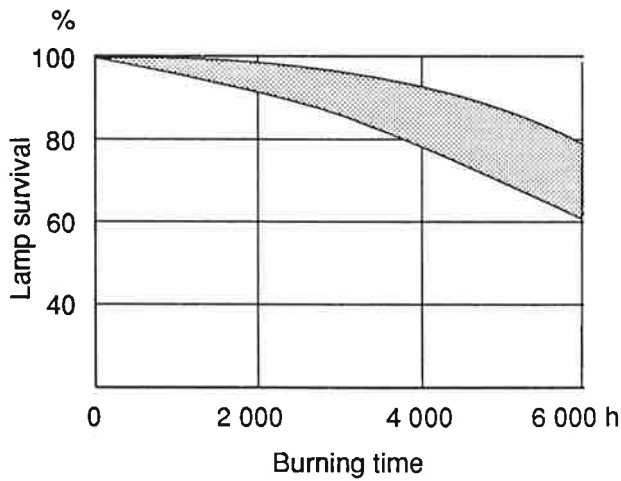

Lamp mortality

3. Principles of operation

HSI-M-TD 150W/WDL lamps are part of the metal halide lamp family, using a multitude of metal additives in form of halides in the discharge mechanism.

The arc tube contains :

- 1) Argon gas, which is required to start the discharge of the arc tube.
- 2) Mercury, which is acting as a discharge basis, and is regulating the electrical properties (lamp power, lamp voltage and current)
- 3) Various metals in chemical combination with iodine and bromine. These halides dissociate into metal atoms and free iodine at the temperatures in the core of the discharge.

The free metals then actively take part in the discharge, are excited and radiate with their particular spectrum.

In the lower temperature zone towards the arc tube wall, the metals recombine with the halogens, and the quartz glass of the arc tube is not chemically attacked by them.

Metal halide lamps require more attention in the design of the fixture and the choke to match the operating conditions and tolerances in order to perform according to their specified data.

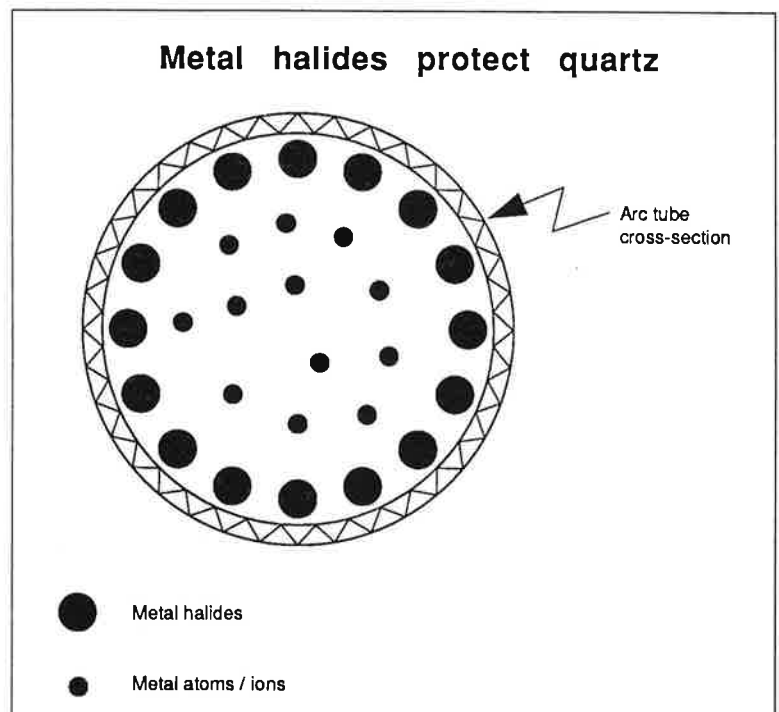

In the following is a listing of the various elements which play a role in the discharge of an HSI-M-TD 150W/WDL. The effect of the single element radiations as they are indicated can be observed in the spectral power distribution diagram of the lamp.

Which metals as additives ?

When we look at the spectra of the various metals and select those which may be useful with respect to their radiation in the visible spectrum, then there are still 50 elements available.

But there are other necessary properties which these elements must have, particularly when they are in chemical combination with a halogen (iodine or bromine). These properties are :

- 1) the elements must not be highly toxic.
- 2) at room temperature the vapour pressure of the halide must be low, so as not to affect the starting properties of the arc tube.
- 3) at high temperatures in the discharge column the halide must be unstable so that the metal can freely participate in the discharge.
- 4) the halide must not react with the quartz glass of the arc tube.
- 5) at arc tube temperatures the halide must go into vapour form, and its vapour pressure must match the conditions created by the other additives.

Other elements than those listed for the HSI-M-TD 150W/WDL which are commonly used in other metal halide lamps are Tin, Indium, Thallium, Lithium, Holmium and Dysprosium (for 6000K lamps).

Chemical fill

<i>Element</i>	<i>Purpose</i>
Scandium	Large band blue and green radiation
Sodium	Narrowband yellow radiation
Cesium	Narrowband red radiation, arc broadening
Iodine	In combination with metals
Mercury	Power loading, narrowband blue and green radiation
Argon	Buffer gas

4. Electrical parameters, equipment and lamp testing

The ignition of HSI-M-TD 150W/WDL lamps

We need an ignitor to start the discharge in the arc tube. The ignitor must provide voltage spikes in the order of 4000 volts with a pulse width of 2 μ s at 90% of peak voltage, superimposed on the open circuit voltage between 50 and 90° phase angle of each half cycle.

The starting phases are shown in the following diagram. The high voltage pulses cause the breakdown (ionisation) of the low pressure argon/mercury atmosphere in the arc tube. During a short time the discharge goes through a glow stage until the arc is firmly established in the mercury vapour. At this moment we have a low pressure mercury arc vapour discharge which mainly produces UVC radiation (as in a fluorescent lamp).

*As the quartz glass of the arc tube and the outer envelope is freely transmitting this UVC radiation, we have here the first reason why these lamps must be operated in a fixture with a protection front glass.
See also p.33*

The heat which is developed by the discharge will now evaporate all the mercury, which means an increase of mercury vapour pressure and temperature, as shown in the table. From about 400 °C on, the metal halides start to evaporate. Stable conditions are reached with an arc tube temperature of about 800 °C and a total pressure of about 10 bar (pg 10). Once the arc tube has reached these operating conditions the initial UVC radiation is fully absorbed in the plasma.

Lamp starting phases

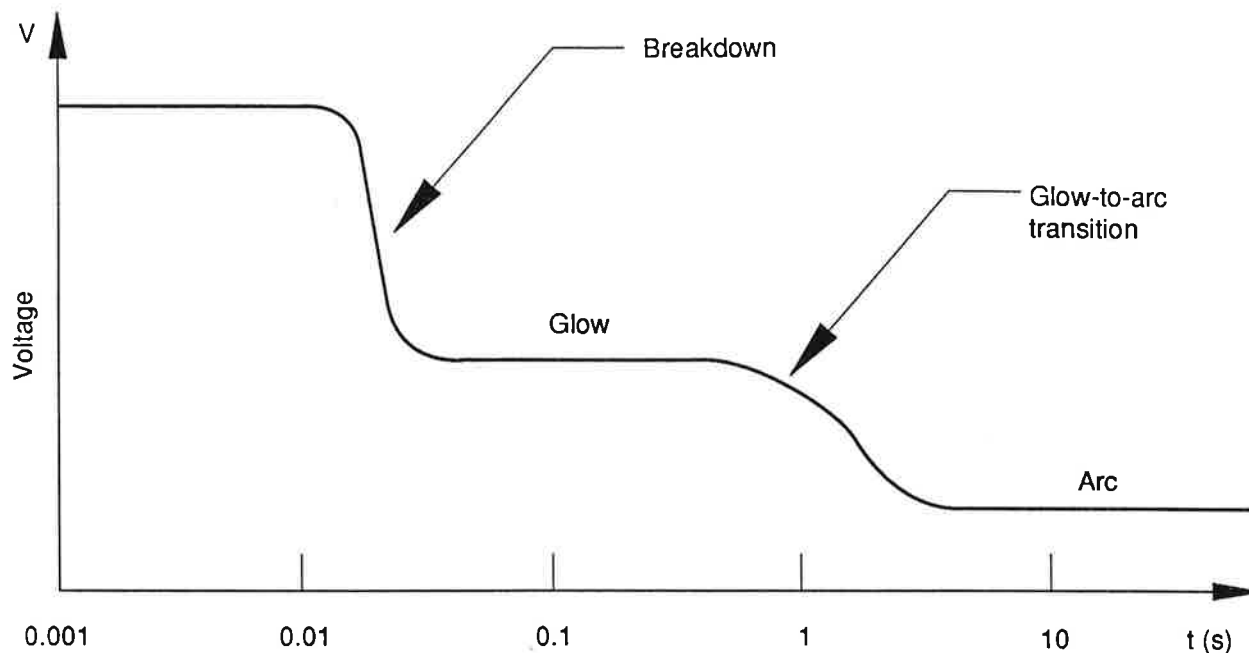

Characteristic pressure

Phase	Time	Temp.	Pressure		
			Ar	Hg	Metal Halides
Ignition	0	25 °C	100 mbar	0.003 mbar	0
Initial	5s	50 °C	108 mbar	0.02 mbar	0
Warm up	75s	400 °C	240 mbar	2 bar	200 mbar
Operation	200s	800 °C	0.5 bar	8 bar	1 bar

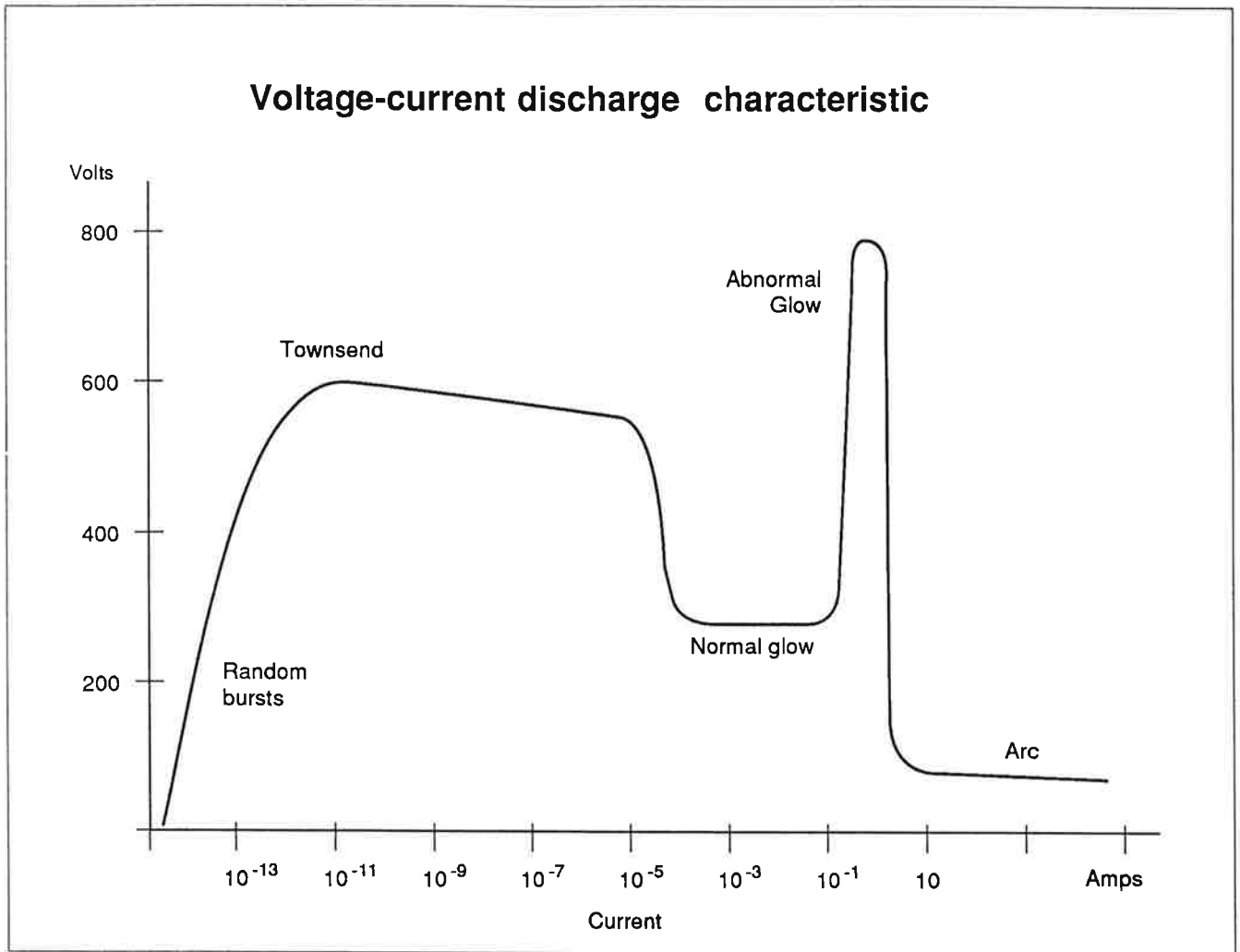

This curve shows the principle of the relation between voltage and current of a gas discharge

Run-up conditions of HSI-M-TD 150W/WDL

The current at the beginning of the run-up time is about 30% higher than the nominal operating current.

It is recommended that a slow acting fuse is used for the protection of the installation with twice the value of the nominal operating current.

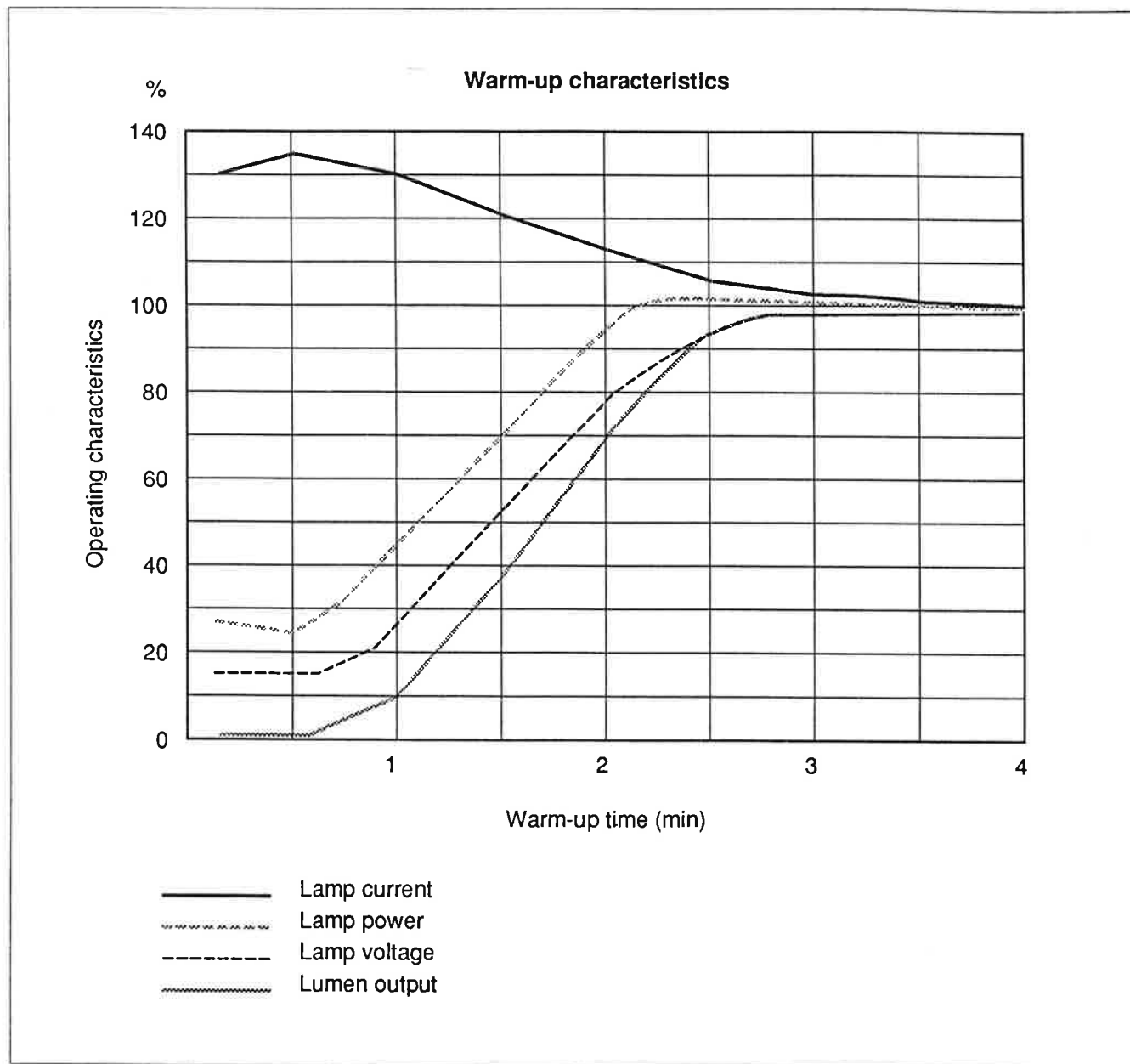

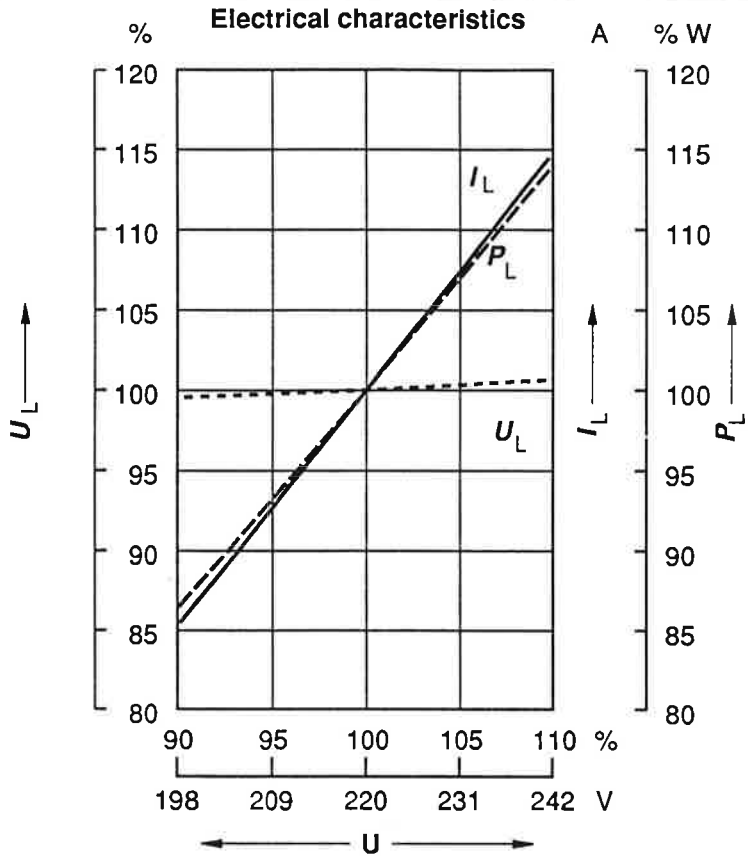

- U_L = Lamp Voltage (V)
- P_L = Lamp Power (W)
- I_L = Lamp Current (A)
- U = Mains Voltage (V)
- Φ = Luminous Flux
- T_c = Correlated Colour Temperature (K)
- η = Lamp Efficiency

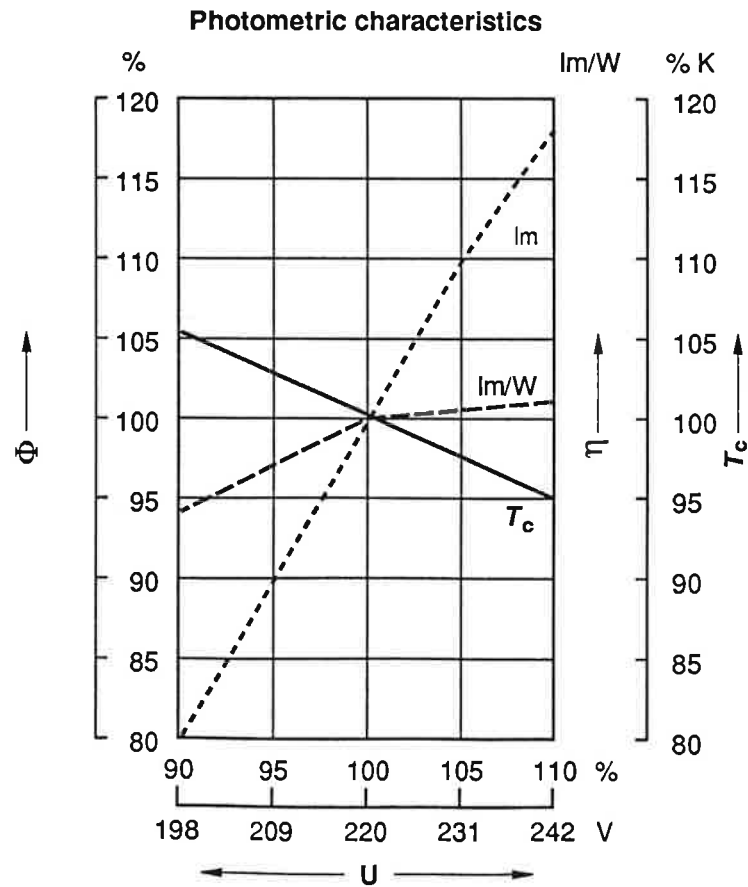

Influence of Lamp Operating Voltage on Lamp Performance

Deviation from nominal supply voltage	Effect	Value
> + 10 V	Lower Colour Temperature Shorter Life	$\leq - 150K$ - 1500h
> + 5 V	Lower Colour Temperature Slightly Reduced Life	$\leq - 100K$
$\pm 5 V$	Nominal Lamp Performance	
< - 5 V	Higher Colour Temperature	$\geq + 100K$
< - 10 V	Higher Colour Temperature	$\geq + 150K$

Mains Voltage and Harmonics

The maximum lamp operating voltage was chosen in such a way that the lamp will not extinguish with a mains voltage reduction of -10%.

According to IEC specifications this test is done under the condition that the mains voltage does not contain more than 3% harmonics.

3 Phase Systems

1) 127 V / 220 V System

If parallel compensated circuits are connected to such a system then resonance conditions can occur if one of the phases (each one equipped with a separate fuse) are disconnected. The increased current can then endanger the lamp, the choke and the capacitor.

It is therefore recommended that a circuit breaker is used which always cuts out all 3 phases together for a group of fixtures.

2) 220 V / 380 V System

Similar conditions may develop on this type of system when the neutral conductor is disconnected.

Ignitors for HSI-M-TD 150W/WDL lamps

Four different types of conventional ignitors are used to start these lamps. The diagrams are shown in the following.

1) Electronic superimposed pulse ignitors, with 3 connections.

This type with 3 connections is the most commonly used one. An integrated pulse transformer superimposes the voltage pulse on the open circuit voltage. A blocking capacitor on the connection to the choke reduces the voltage pulses, so that no special insulation of the choke or the wires are required. On the contrary, the connection between the ignitor and the lamp carries high voltage and an adequate insulation has to be foreseen.

For the choice of such an ignitor 3 characteristics are important :

- a) The ignitor must provide the specified voltage pulses
- b) The current rating of the ignitor must be sufficient (because the lamp current passes through the ignitor)
- c) The maximum capacitive load created by the cable between the ignitor and the lamp must be respected. Typical values are 100 pF for 1.5 m of cable.

For the design of the fixture the temperature limits of the ignitor have to be respected.

2) Electronic superimposed pulse ignitors., with 2 connections.

This type with 2 connections operates also with an integrated pulse transformer. There is no protection of the choke from the high voltage spikes, and only chokes with adequate insulation can be used.

The capacitive load for this type of starter may be up to 1000 pF, permitting cable lengths of up to 15 m. Depending on the installation, the ignitor can be installed with the choke or with the lamp.

Both starter types as described under 1) and 2) are deactivated after the lamp has started (because they are then at lamp voltage). On the contrary, if a lamp does not start, or, if a lamp is missing in the fixture, these ignitors will continue generally to function.

This means that the cable insulation of the high voltage carrying cables must be chosen carefully.

It is also recommended that a warning notice is applied, to advise that fixtures are disconnected to change the lamp or when a lamp is missing.

3) *Electronic ignitors using part of the choke as transformer*

This requires a special choke with intermediate tapping for the connection of the ignitor.

The capacitive load with such a system may be up to 1000 pF which permits cable lengths up to 15 m.

For the safe operation of this system a capacitor must be installed parallel to the circuit. The minimum capacitance is indicated by the ignitor manufacturer.

4) *Ignitors for instant restart*

Voltage pulses of up to 35 kV peak and 20 - 30 pulses per half cycle are required for instant restarting of a hot lamp. Only electronic superimposed pulse ignitors are suitable.

In general, the action time of these ignitors is very short (2 seconds) because the restriking time is less than a few 10ths of a second.

This action time, however, must be adjusted in such a way that the lamp is also started if it should extinguish after the first restrike.

In addition, a short time cut out switch is installed in the circuit, as a protection in case a lamp does not start any more, as under end of life conditions.

The correct circuit installation as well as additional components are listed by the ignitor manufacturer.

Because of the high voltages involved, the fixture must be equipped with a safety switch to the choke compartment which disconnects the circuit when the compartment is opened for service.

Ignitor / Control gear circuits

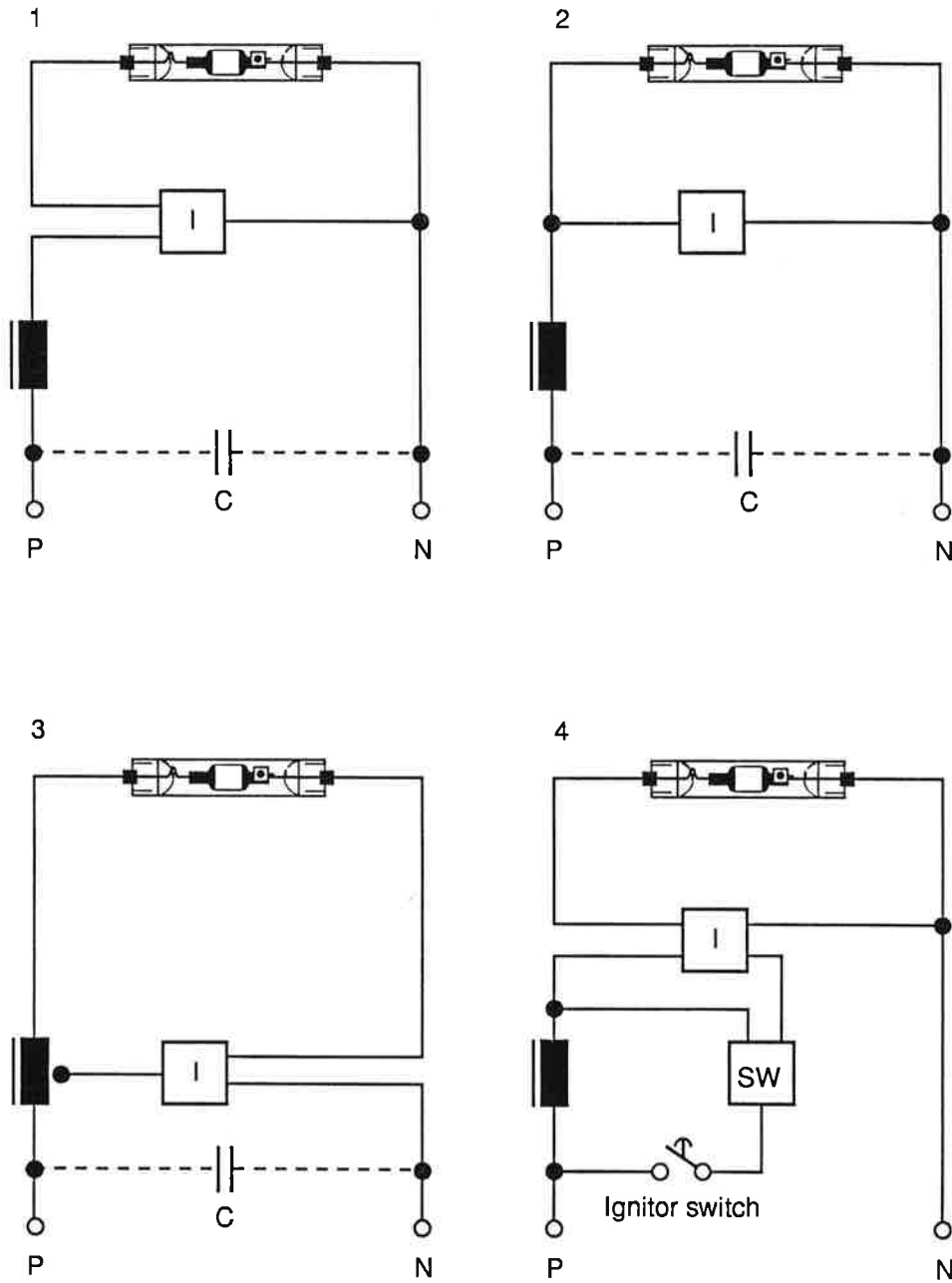

C = power factor correcting capacitor
 SW = short time switch

Chokes for HSI-M-TD 150W/WDL

In-line chokes are usually used with this type of lamps, less frequently autotransformer units or constant wattage chokes.

It is important is that the impedance of the choke is within $\pm 3\%$ of the specified value. This low tolerance is necessary to assure that the lamp will perform to its performance specifications.

Furthermore it is strongly recommended that the choke is equipped with a + 5% tapping of the nominal mains voltage (that is 230 V over 220 V) to permit the connection of the circuit to the prevailing supply voltage conditions.

Mains voltage variation

For the same concern with product performance we specify the mains voltage to be within $\pm 5\%$ of the nominal value, at which the choke is connected

For the installation of the fixture, we recommend that the actual mains voltage is measured and that the choke is connected at the most suitable voltage terminal.

Thermal protection of choke

At the end of life HSI-M-TD 150W/WDL lamps may assume an anomalous operating mode characterised by higher current flow. This may cause damage to the choke by overheating. It is therefore recommended that only chokes which are protected by means of a properly selected thermal fuse are used.

Chokes for HSI-M-TD 150W/WDL

ABB (BBC)

1. SOH/DJ 150/2 KU-K-V551/552*	with thermo-protection	220/230V
2. SOH/DJ 150/2KU-K-70-V551/552		220/230V
3. SOH/DJ 150/23KU-K-V551/552*	with thermo-protection	230/240V

May and Christe

1. NQI 150 -24.2- 23T SW*	with thermo-protection	220/230V
2. NQI 150 -24.2 K38T SW*	with thermo-protection	230/240/250V
3. NQI 150 -24.2- 23		220/230V
4. NQI 150 -0.3.2 H23		220/230V

Schwabe

1. NAHJ 150.526*	with thermo-protection	230/240/252V
2. NAHJ 150.489		220/230/240V

Zumtobel

1. OMBIS 150W B105 (TP)*	with thermo-protection	230/240/250V
2. OMBIS 150W B105		230/240/250V
3. OMBIS 150W		220/240V

Leuenberger

1. XI/XHp*	with thermo-protection	220/230V
2. XI/XHv		220/230V
3. XI/XHo		220/230V

Parry u. Co. (Nottingham)

1. HSV 163 212 B3	with thermo-protection	210/220/230V
2. HSV 163 222 B3*	" " "	220/230/240V
3. HSV 163 232 B3*	" " "	230/240/250V

Ignitors for HSI-150W

1. ABB (BBC)	MZN 250-SE	220/240V
2. Bag Turgi	MZN 150-S	220/240V
	MZN 250-SE	
3. May u. Christe	ZG 4,5 SE	220/240V
4. Zumtobel	ZRM 6-ES	220/240V
	ZRM 1.8-ES/2	220/240V
5. Parry u. Co.	PWE 400255	220/240V

Lamp Holder Rx7s

1. Bender and Wirth	Nr. 939/Nr. 957
2. Vossloh	Nr. 30602/Nr. 31602/Nr. 32326

* Recommended

Power Factor Correction

Based on a circuit current of 1,8A, an effective lamp power of 150W, ballast losses of 16 W (176W circuit power) and a mains voltage of 230V, capacitances for parallel compensation are as follows:

$$\cos \varphi = 0.9 \quad c = 20 \mu\text{F}$$

Capacitor tolerances and actual choke losses have to be considered and may increase above indicated values. For other circuit conditions the capacitance can be calculated as follows :

$$C = \frac{1}{2\pi \times f \times U_N^2} \times \left[\sqrt{(U_N^2 \times I_L^2) - P^2} - (P \times \text{tg} \varphi) \right]$$

- C capacitance
- U_N Mains Voltage
- f Mains frequency
- I_L Lamp Current
- P Circuit Power (Lamp+ Choke)

tgφ = 0.75	for cos φ = 0.8
0.62	0.85
0.49	0.9
0.33	0.95

Radio Interference

Parallel compensated circuits with superimposed pulse ignitors will operate within the recommendations for radio interference suppression. It is recommended that ignitors are used which have been approved for this issue.

Dimming of HSI-M-TD 150W/WDL Lamps

We do not recommend that these lamps are dimmed because of the strong change in colour temperature, colour rendition and a reduction of lamp life.

HSI-M-TD 150W/WDL Lamp testing

Electrical, photometric and colorimetric data

HSI-M-TD 150W/WDL lamps will reach their operating temperature and pressure only in a fixture. However, to eliminate the influence of fixture design on measurements, a test luminaire was developed as is shown in the corresponding diagram (p.22).

It consists of a quartz glass tube with aluminium end plates which hold the lamp. For test/measurement purposes the lamp will operate in a horizontal position and will develop in this test fixture a lamp ambient temperature of about 150 °C.

Test equipment

Measurements are made in an integration sphere with a diameter of 1.5 m. The room temperature is controlled to 25 °C ± 1 °C.

For measurements the lamps are operated on a reference choke with the input voltage to the circuit being controlled to ± 0.1% of the nominal voltage.

Measuring equipment

For electrical measurements only "true RMS" instruments are suitable because of the non-sinoidal voltage and current wave forms. The crest factor capability should be better than 2.5.

The instrument has to be protected from high voltage spikes from the ignitor when lamp voltage is measured (these spikes may be as high as 4.5 kV).

The apparent lamp power factor is about 0.88.

Lamp ageing

The lamps have to be aged before 100h measurement. Nominal lamp data are referred to at 100 hours (or 2000 hours in the UK for lumen data).

The ageing is done in commercial fixtures which comply in their designs with recommendations given in this manual.

The switch cycle for ageing is 11.5 hours on, 0.5 hour off.

Lamp Position

The factory procedure is to age and test/measure lamp operation in the horizontal position with the tip-off on the arc tube showing sideways within a tolerance of $\pm 5^\circ$. This is to avoid halide condensation in the area when operated tip-off downward.

When lamps are taken from the ageing racks to the measurement station they are maintained in the same horizontal and rotational position to avoid any changes with respect to halide condensation.

Lamp stabilisation before measurement

Light output and lamp voltage must be stable. In general 15 minutes are sufficient to achieve this.

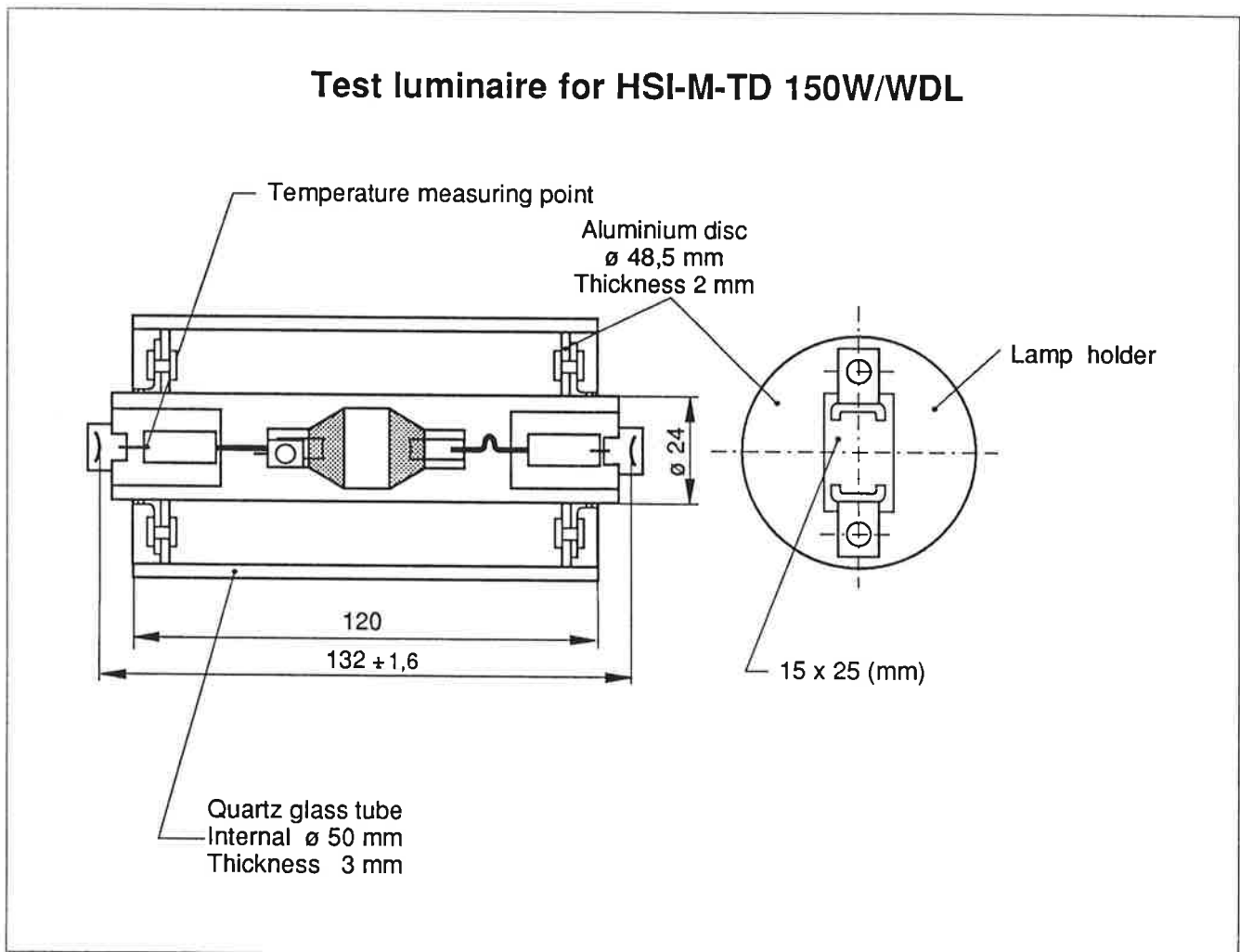

5. Utilisation and application

Handling of HSI-M-TD 150W/WDL lamps

Because of the outer quartz glass envelope and the high temperatures, these lamps should not be touched with bare fingers when inserting them into the fixture.

If this happens then clean them with alcohol and a clean tissue.

Inserting the lamp

1. *The fixture must be disconnected to avoid an electric shock. Remember that the ignitor provides voltage spikes of up to 4.5 kVs.*
2. Avoid lateral pressure on the contacts, use axial pressure only when inserting.

Some problems may occur in adverse conditions created by blade spring lamp holders when their installation is done on the minimum side of distance tolerances, with lamps of maximum length tolerance. It may be useful in such cases to readjust one lamp holder position.

Operating position

The specified operating position is HORIZONTAL and tip-off of the arc tube sideways in which mode the lamp will perform according to the rated photometric and colorimetric values.

The tolerance is $\pm 45^\circ$. In these extremes there will be slight changes in colour temperature but also lamp life will be reduced.

Should the tip-off of the arc tube not be sideways, a too-high colour temperature will be observed.

Radiation and colour fading

Any radiation (ultraviolet, visible and even infrared) from a light source, artificial or natural light, will cause changes in colours. The principle criteria for such changes are :

1. The resistance of the pigment or dye to radiation. Various standards exist on this subject.
2. Radiation level in lux or W/m^2 and maybe by wavelength range.
3. Type of radiation, see spectral power distribution.
4. Exposure time.

Other additional influences come from the environment in terms of moisture or vapours which may accelerate colour fading.

Other effects on materials caused by radiation are embrittlement, polymerisation, softening or dimensional changes and cracking, in extreme cases.

In general we can say that the shorter the wavelength, the higher their energy to change things. For the radiation from HSI-M-TD-150W/WDL lamps this means that we should use filter glass for cutting out UV radiation, where continuously high illuminance levels are required.

The various diagrams provide additional information.

- **Absorption curves for various glass types** . Please note that the average glass or filter will reduce the light output from the fixture by about 10 - 20% across the visible spectrum.
- **Comparative natural daylight spectrum and the spectrum of the HSI-M-TD 150W/WDL**
- **Photo-biological radiation responses to radiation, with respect to the human being.**
- **Photo-biological radiation responses of plants.**

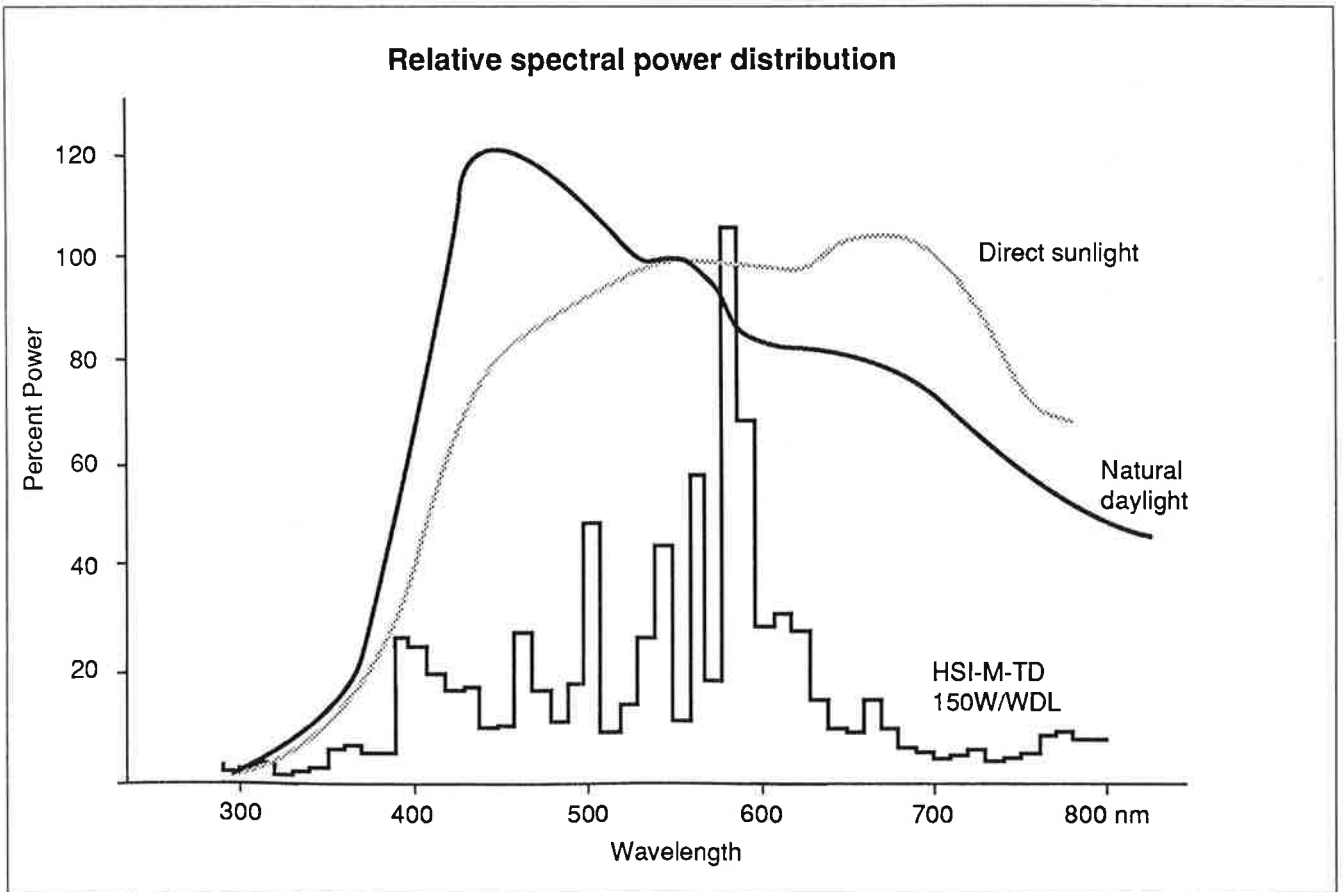
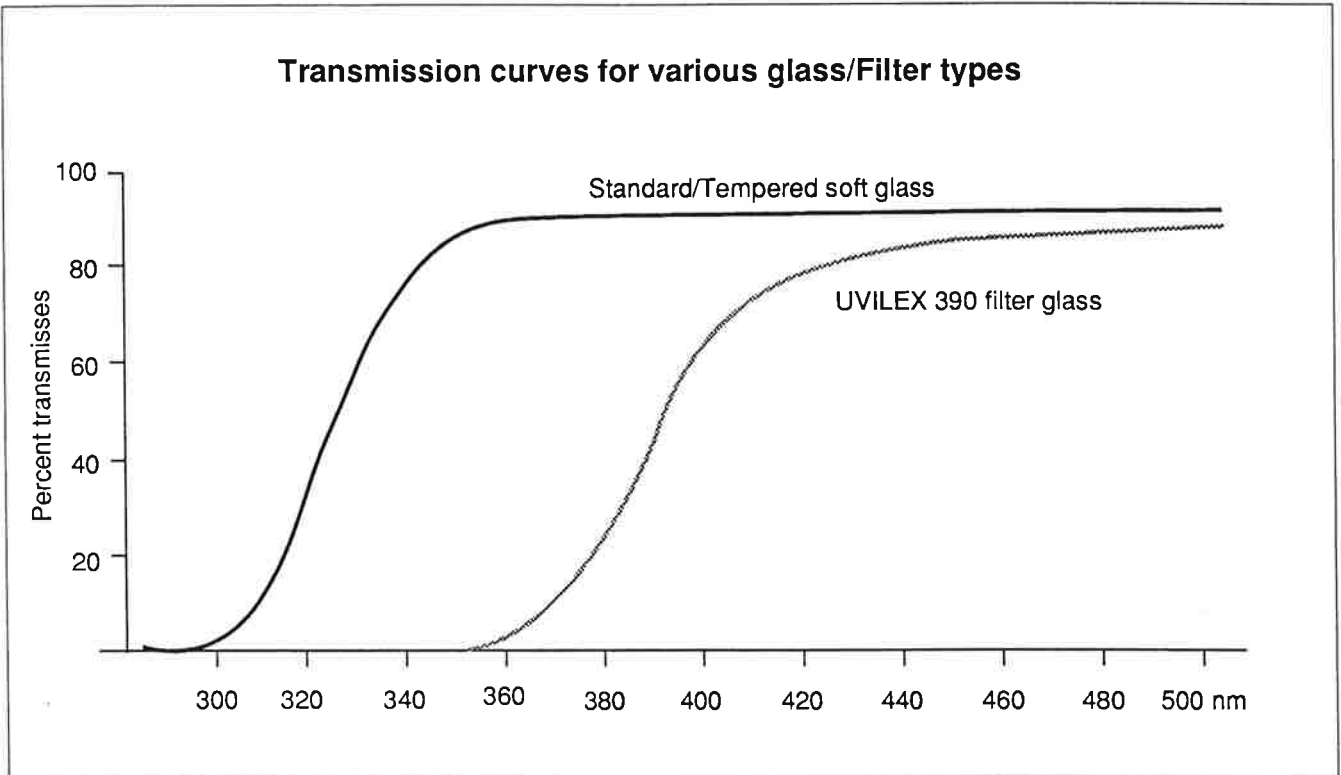

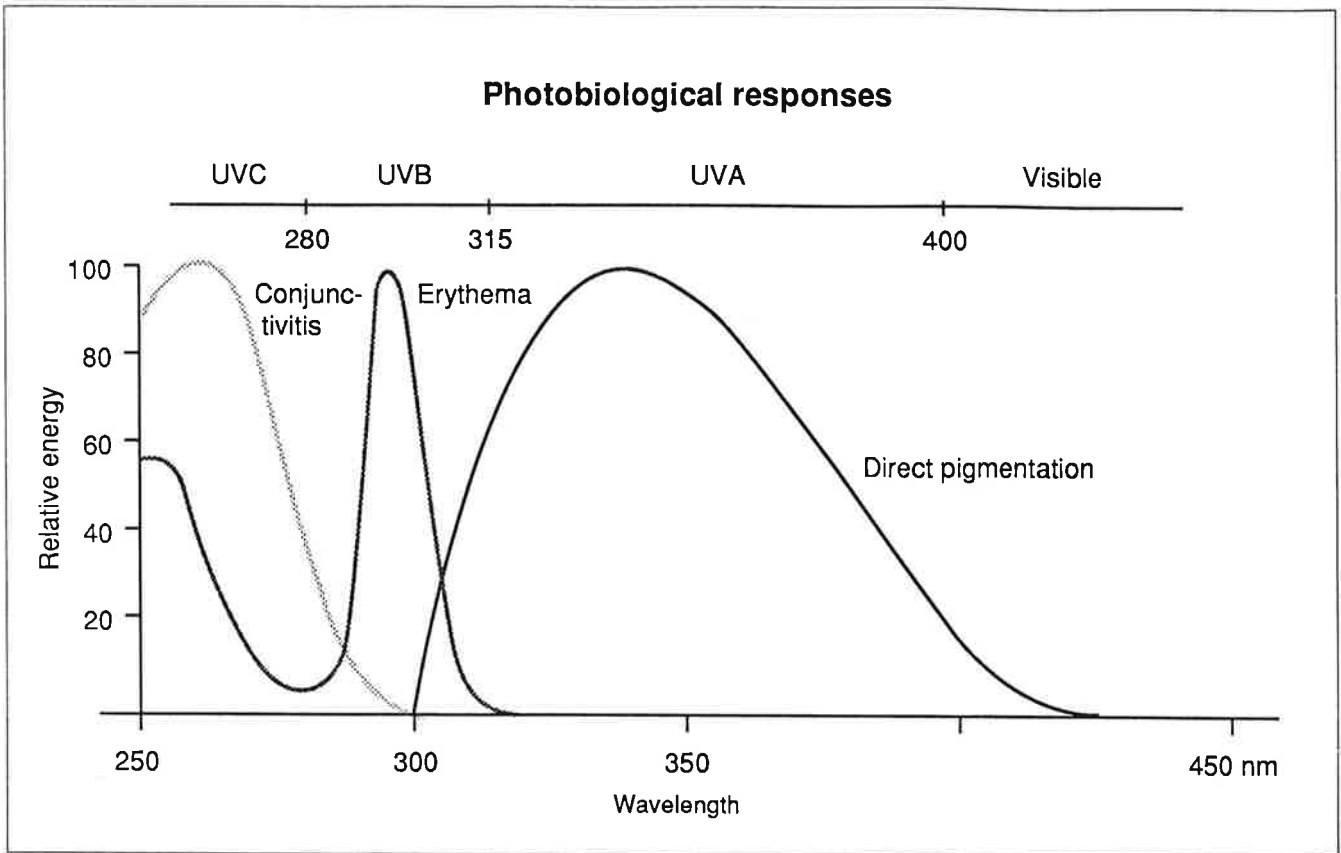

The above are presented for information purposes only. Care should be taken to protect skin and eyes from prolonged direct radiation from the HSI-TD lamp or a protective glass used (see p.33).

Horticultural application data

- (A) Photosynthetic response
- (B) Chorophyll synthesis

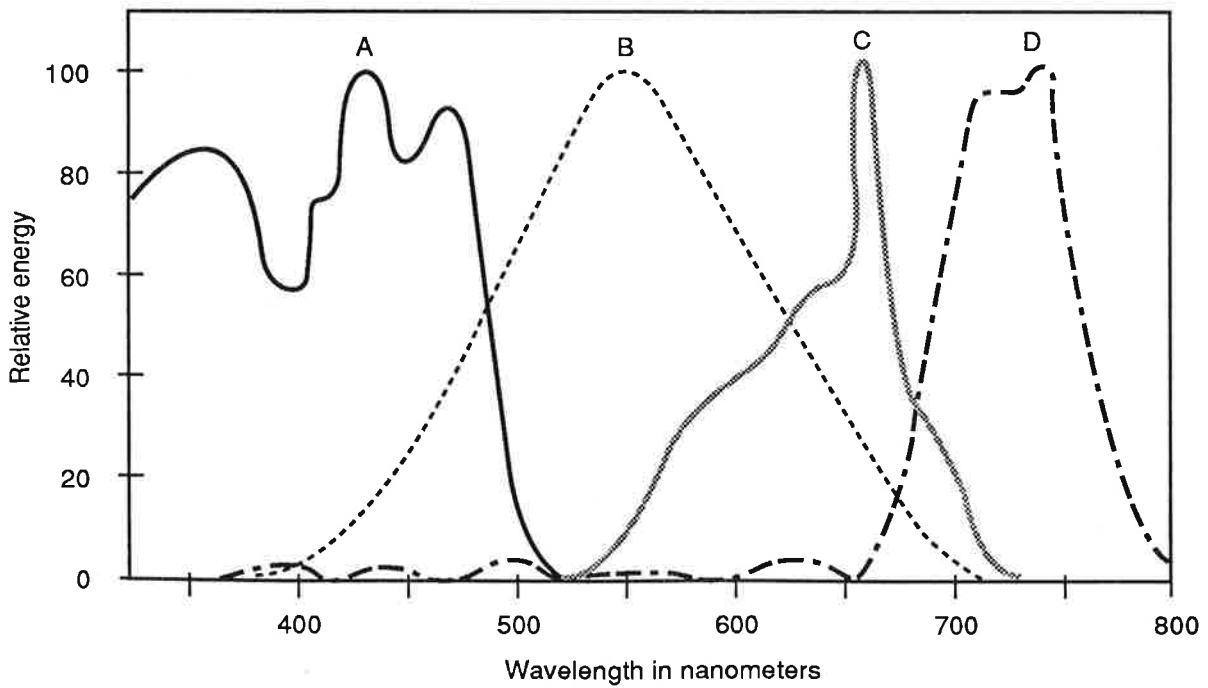
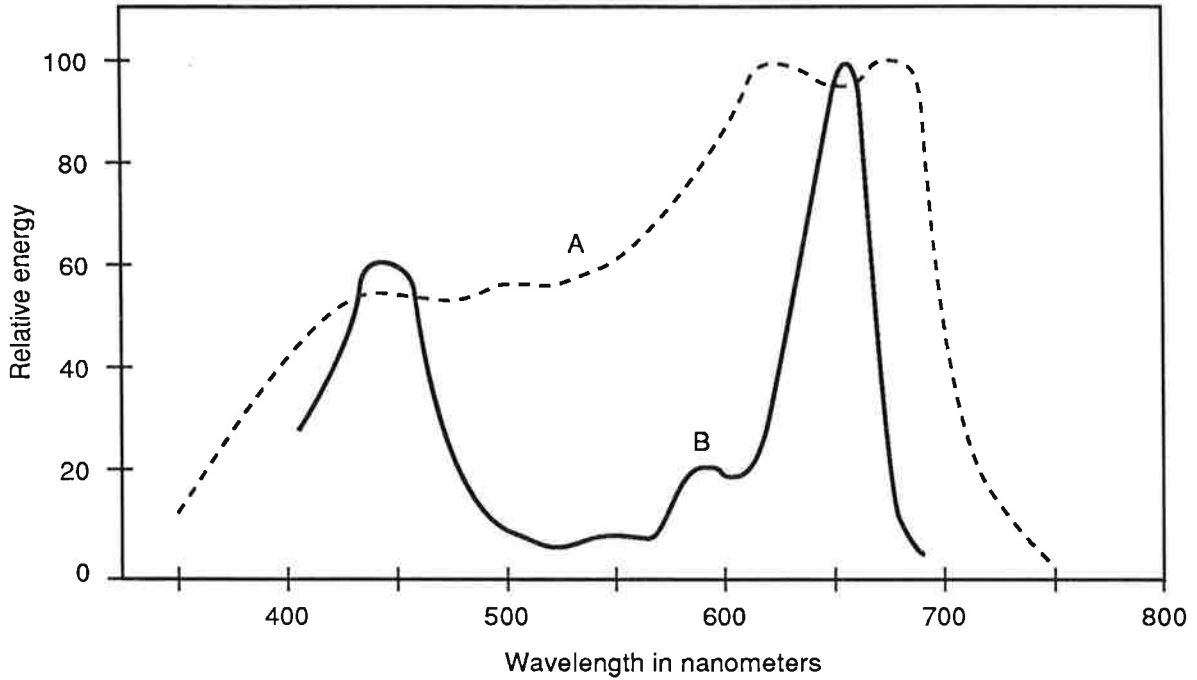

Action spectrum of:

- (A) Phototropic response
- (B) Photopic vision (Eye sensitivity curve)
- (C) Photomorphogenic induction (Pr)
- (D) Photomorphogenic reversal (Pfr)

Exposure Time

The following tables indicate permissible exposure times for 1000 lux natural daylight and various categories of pigment/dye resistance. The information is by DESAG with the UVILEX 390 filter glass.

Resistance to fading categories	Permissible exposure to daylight (1000) Lux	
1	very light sensitive	70 hours
2		150 hours
3	↑	300 hours
4	↓	600 hours
5		1200 hours
6		2500 hours
7		5000 hours
8	less light sensitive	10000 hours

Table 1 : Permissible exposure time for various resistance to fading categories

Light source	Multiplication factors compared with daylight	
	without UV filter	with DESAG-UV-barrier filter
Halogen and fluorescent lamps	2	4
Metal halide lamps	1.5	2.5

Table 2 : Multiplication factors for different types of lamp compared with daylight

6. Recommendations for fixture design

The general rules as outlined in I.E.C. Publication Nr. 598 with its amendments apply, respectively the E.E.C. standard EN 60-598.

In the following are further recommendations as far as the lamp (HSI-M-TD 150W/WDL) is concerned.

Thermal considerations for fixture

The following recommendations and limitations are valid for fixture operation at + 5% of nominal mains voltage (choke connection) and for a choke with + 3% maximum current tolerance. Furthermore for a lamp with nominal operating voltage.

1) *Lamp ambient temperature*

The HSI-M-TD 150W/WDL was designed to reach its nominal performance data in an ambient temperature of 150 degrees Celsius.

2) *Minimum starting temperature*

The lamp will start with an adequate choke and ignitor at temperatures of minus 35 degrees Celsius and above.

3) *Maximum temperatures*

The fixture design has to guarantee two limit temperatures at the lamp :

- a) A maximum bulb temperature of 650 °C. The following diagram shows how to attach a thermocouple element to the bulb. The maximum temperature is to be expected in the center of the lamp length.
- b) A maximum temperature of 280 °C at the pinch seals (molybdenum foil), the measuring points are indicated in the following drawing.

For both measurements (a) and b) the most unfavourable position of the fixture has to be chosen, within the ± 45 degrees from horizontal of the lamp operating position.

Both maximum temperature limits are usually achieved when the measuring points for b) do not exceed 200 degrees Celsius.

The bulb temperature measurement will be inaccurate (too high) because the thermocouple will be heated differentially by the radiation from the arc-tube.

It is therefore recommended that a cooling down curve is established (measured) after the lamp is switched off. The values are plotted on a single logarithmic paper as shown in the following diagram and the curve (close to a straight line) can be extrapolated to the approximate bulb temperature at the moment when the lamp is switched off.

4) *Temperature limits of other circuit components*

For these limits please refer to the indications given by the manufacturer of the choke, ignitor and capacitor.

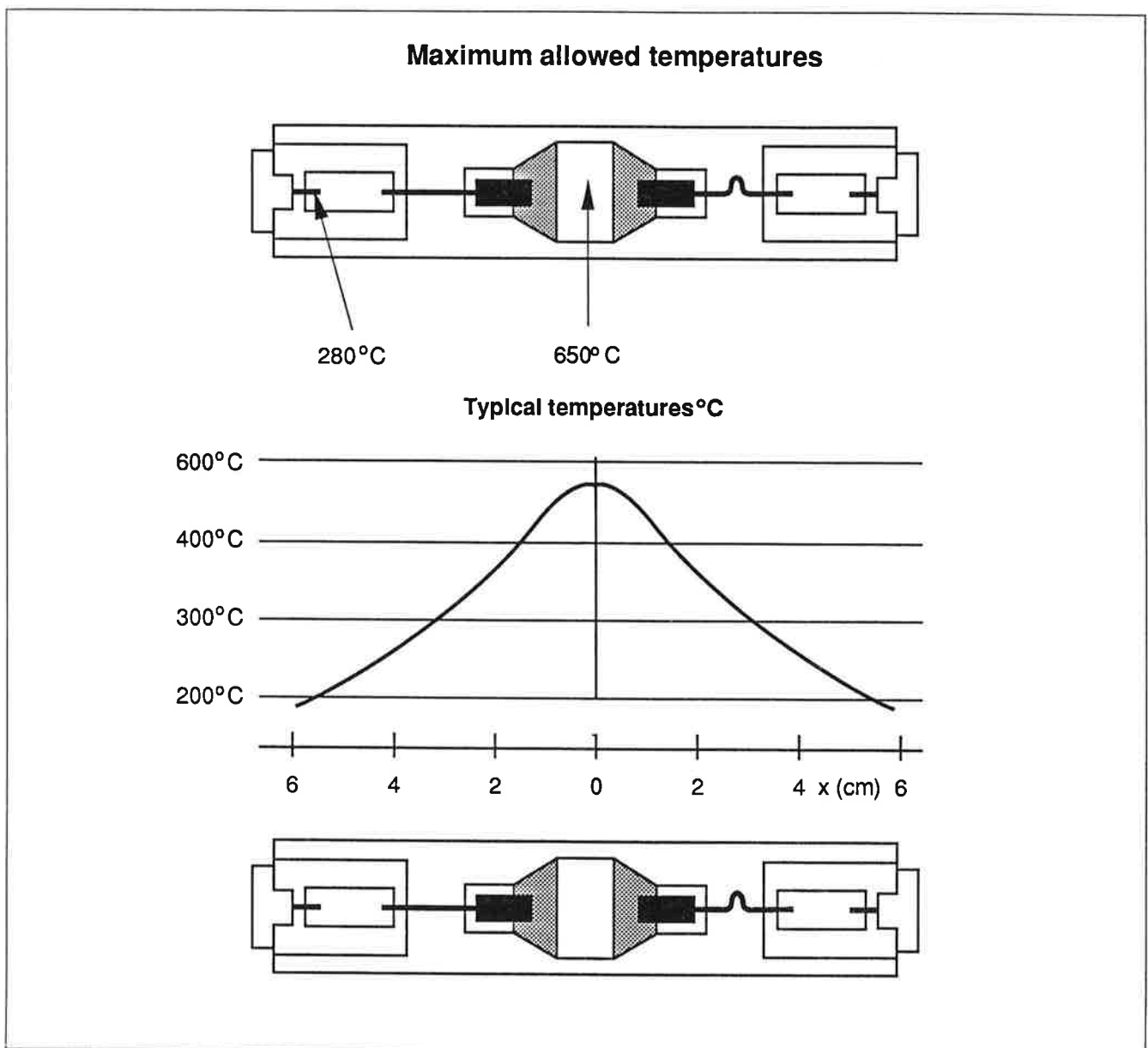

Temperature measurements

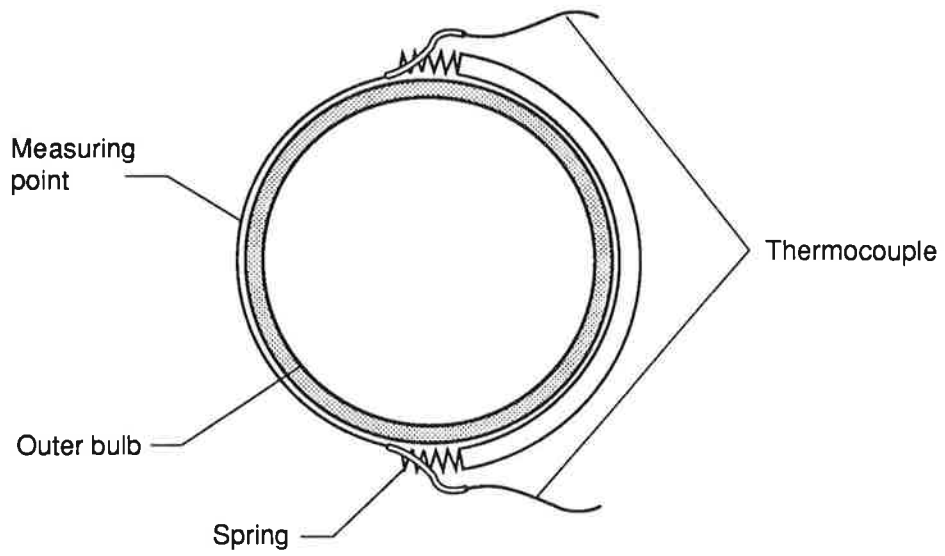

Principle of temperature recording

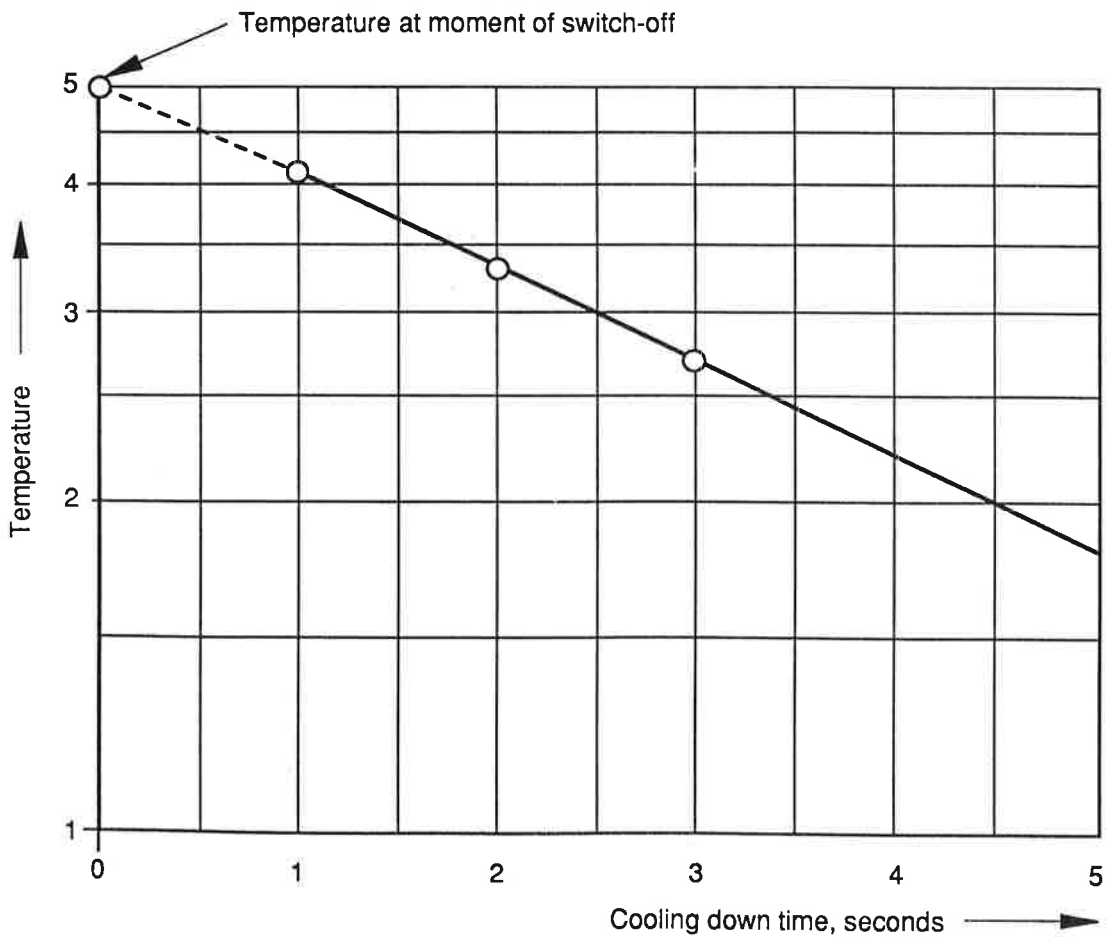

Lamp holders RX7s / installation

Considering the expected ambient temperature conditions and the required electrical insulation for the parts carrying high voltage, the lamp holders should be installed according to the recommendations of the manufacturer.

With concern for a proper electrical contact between the lamp and lamp holders, as well as for ease of inserting the lamp, the recommendations as given in I.E.C. Nr. 61-2 (lamp holders) with reference to specification sheet 7005-52-2 should be respected.

The HSI-M-TD 150W/WDL lamp length data are as follows :

- 1) length contact-contact 132 ± 1.6 mm.
- 2) insertion length 135.4 mm maximum.
- 3) overall length ceramic end - ceramic end 137.4 mm maximum.

See data sheet for dimensions.

Reflector design/materials

The arc discharge of metal halide lamps can be colour structured. It is therefore recommended that a material surface is used for the reflector which mixes these colour zones.

To avoid any back infrared radiation from the reflector on to the arc tube (which will cause operating voltage increase) the recommendations as per the following drawings should be followed.

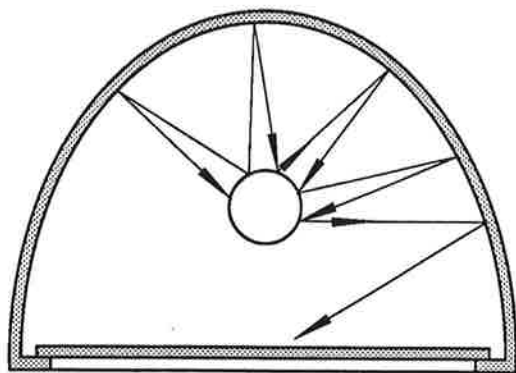

Fig.1 Reflector with inadmissible infrared reflection to the quartz glass tube

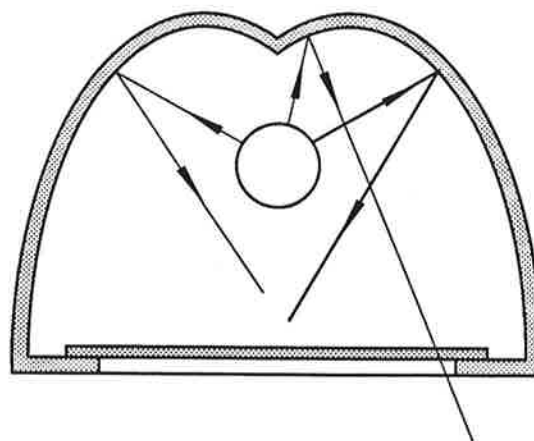

Fig.2. Reflector with reduced infrared reflection to the quartz glass tube

Fixture influence on lamp operating voltage

The fixture design (temperatures on the lamp) and the shape of the reflector (back radiation on the arc tube) will influence the lamp operating voltage.

An increase in lamp operating voltage causes an increase in lamp wattage and consequently a change in the photometric and colorimetric performance. The lamp life is negatively affected

The reflector and fixture design should be such that the lamp voltage does not increase more than 10 volts compared to operating in free air.

Magnetic fields

For both, ignitors and chokes, care should be taken that stray magnetic fields may not influence the arc discharge of the lamp.

Fixture materials

Because of the relatively high temperatures and the ultraviolet radiation present, plastic materials, varnish and insulation products have to be resistant to these conditions. They should not give off harmful vapours to other components of the fixture.

Front glass

A fixture operating a HSI-M-TD 150W/WDL lamp must be equipped with a front glass. This can be made of tempered soft glass, hard glass, or of a special filter glass to reduce or cut-out the UV radiation

A front glass is required for following reasons :

1. Safety protection of the illuminated area in case of non-passive lamp failure
2. Absorption of harmful UVC and UVB radiation which will lead otherwise to skin and eye irritation.

The lamp and reflection from the reflector should never be viewed with unprotected eyes

3. Reduction of short wave UV-A radiation to reduce the fading (bleaching) of colours of illuminated objects, respectively to extend the permissible exposure time (see separate section).

7. Trouble Shooting

1. *Lamp shows bright flash, and does not ignite again. (Strong overload and destruction of lamp.)*
 - no choke
 - choke short circuited (insulation break down)
 - choke wrongly connected
 - capacitor wrongly connected (lamp parrallel not circuit parallel)

2. *Lamp does not ignite*
 - ignitor defect
 - ignitor wrongly connected
 - wrong ignitor (not as specified for the lamp)
 - bad lamp holder or circuit contact
 - mains supply voltage too low, circuit wrongly connected
 - lamp defect or end of life
 - lamp has not cooled down after current interruption

3. *Lamp does not ignite properly, stays in glow stage*
 - lamp was damaged in previous overload
 - ignitor defect

4. *Lamp ignites but extinguishes again (immediately or cyclic)*
 - lamp in not permissible operating position
 - lamp overload conditions because of too high mains voltage, wrong choke connection, defect or wrong choke, capacitor parallel to lamp
 - lamp at end of life. Change lamp
 - fixture design problem, too high lamp temperature, reflector back radiation on burner
 - mains voltage irregular, nearby high power equipment switched on - off.

5. *Lamp flickers, discharge spirals*

- lamp in not permissible operating position.
- lamp operating voltage too high / low. Check choke connection.

6. *Strong blackening of arc-tube, light output reduction*

- overload operation, see mains voltage and choke tolerance.
- wrong or defect choke, choke connection to mains
- capacitor lamp parallel

7. *Fuse is acting immediately or shortly after switch-on*

- overload conditions
- wiring defect
- fuse rating too low. Should be 2x nominal lamp operating current. If rating is adequate replaced only with a fuse of the same rating.

8. *Lamp extinguishes, arc-tube is expanded*

- overload conditions
- magnetic field from the choke deforms arc discharge

9. *Lamp operates with rather greenish light or other abnormal colour, colour differences*

- underload (current /voltage) condition. Check choke, choke-connection, mains voltage
- not permitted operating position especially tip-off in wrong orientation.
- strongly varying operating positions in an installation
- lamps of different operating age
- varying colour schemes of illuminated areas in the same location (apparent colour differences)





SYLVANIA

GTE