

# Discharge lamps



# Atlas Discharge Lamps

**THORN** LIGHTING

## Contents

Introduction	2
Mercury lamp information	4
Sodium lamp information	5
Kolorarc spectral distribution	6
Kolorarc MBIF and MBI metal halide lamps	7
Kolorarc installations	8-9
Kolorlux MBF spectral distribution	10
Kolorlux MBF mercury fluorescent lamps	11
Kolorlux MBFR spectral distribution	12
Kolorlux MBFR mercury reflector lamps	13
Kolor-Plus MBTF and 'Black Light' MBTW mercury tungsten lamps	14
MB mercury lamps	15
Kolorlux MBF and MBFR installations	16-17
KolorSON spectral distribution	18
KolorSON high pressure sodium lamps	19
Linear SLI/H sodium lamps	20
SOX sodium lamps	21
KolorSON and Linear SLI/H installations	22-23
Circuit components: 50W, 80W, 125W and 250W Kolorlux MBF and MBFR mercury discharge lamps	24
Circuit components: 400W, 700W and 1000W Kolorlux MBF and MBFR mercury discharge lamps	25
Circuit components: 400W and 1000W Kolorarc MBIF and MBI metal halide lamps	26
Circuit components: 250W and 400W KolorSON high-pressure sodium discharge lamps	27
Circuit Diagrams	27
Circuit components: SO, SOI, SOX and SLI sodium discharge lamps	28
Capacitors and capacitor clips for mercury and sodium discharge lamp circuits	29
Control gear boxes	30-31
Thorn Group Regional Headquarters and Overseas addresses	32

## Introduction

Thorn Lighting offers the widest choice of discharge lamps in the country. This range enables you to select lamps with the best combination of light output and colour to satisfy your particular requirements. And so, because you get the right lamp for the job, you enjoy maximum operating efficiency and minimum maintenance costs.

Atlas Kolorarc lamps, with their special metallic additives, have no challengers for really accurate colour rendering, so accurate that they have been proved suitable light sources for use with colour television. In any commercial or industrial situation where high light output combined with accurate colour rendering is demanded, Kolorarc lamps are ideal.

Atlas Kolorlux lamps combine good colour with a wide range, stretching from 50W to 1000W, giving exceptional flexibility. The MBFR version, with its internal reflector coating, gives improved lumen maintenance in industrial situations and lowers operating costs.

Atlas Kolor-Plus MBTF lamps take this flexibility even further by requiring no control gear and make excellent long-life replacements for ordinary tungsten filament lamps—especially where maintenance is difficult and costly.

The Atlas KolorSON high pressure sodium lamp is the most efficient in the Kolor range, producing a brilliant golden light. It is becoming increasingly popular for exterior lighting where improved colour is needed, and also for interior use where warm colour is acceptable and high efficacy vital.

The Atlas Linear Sodium and SOX lamps are for outdoor and streetlighting applications and achieve the highest possible light output for the lowest cost.

All Atlas discharge lamps have been developed by Thorn's incomparable research and design facilities and backed by Britain's largest distribution network.

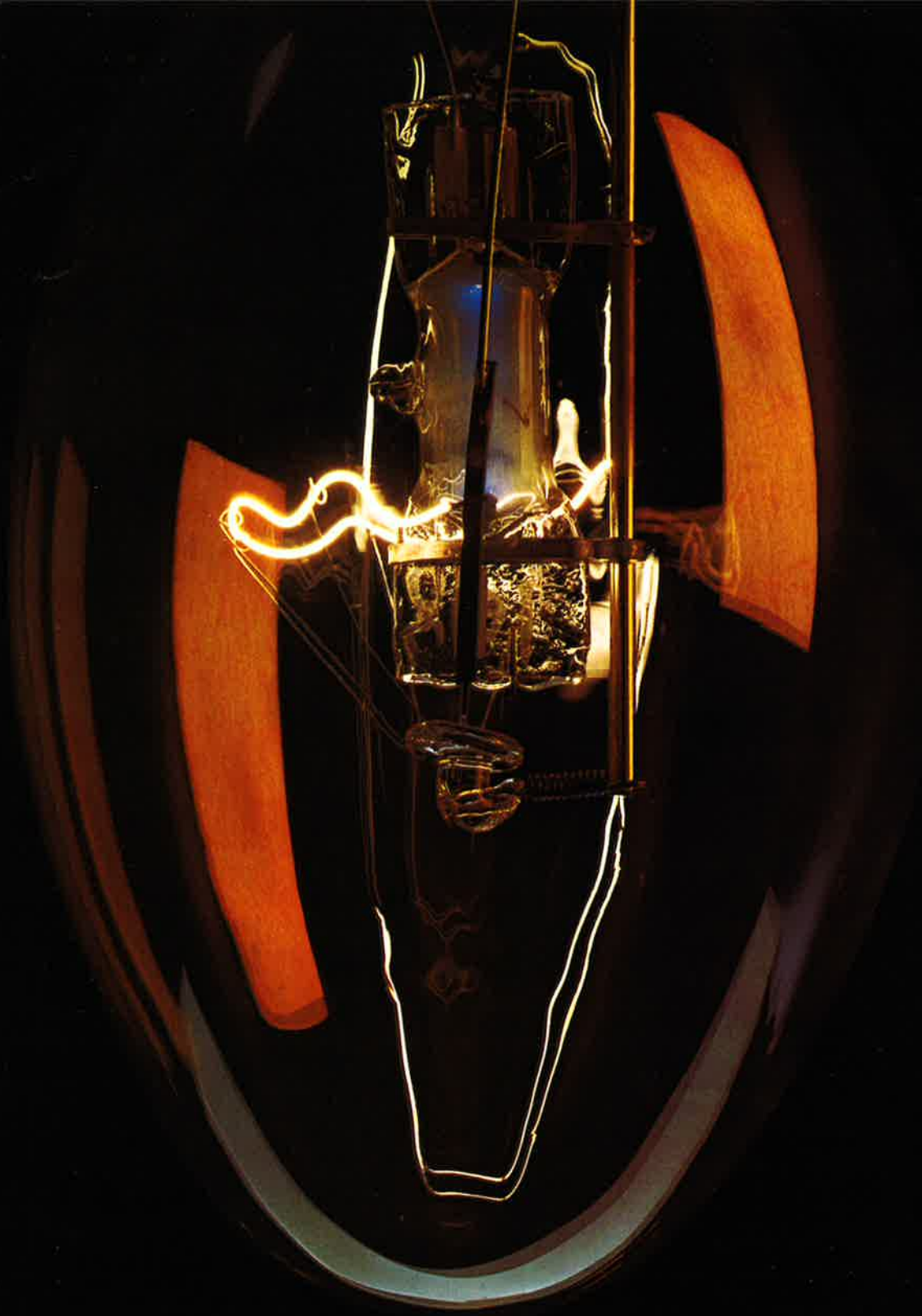

# Mercury lamp information

Lighting Design Lumens

The Lighting Design Lumens quoted are the lamp outputs at 2000 hours and are recommended as a guide to lighting engineers planning scheme lay-outs. Lumen output beyond 2000 hours decreases by 2-3% per 1000 hours use according to type.

1/ Variation of striking voltage with ambient temperature for mercury lamps

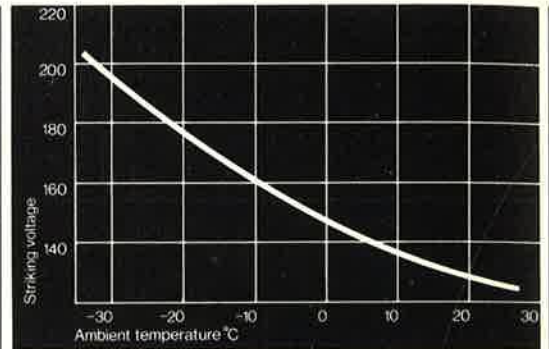

Striking Voltage

Mercury lamps are provided with an auxiliary electrode to initiate starting. Diagram 1 shows that the lamp will start readily under all normal operating temperatures. The striking voltage of MBI and MBIF lamps is not affected by ambient temperature.

2/ Effect of variation of mains voltage on the lamp characteristics of mercury discharge lamps

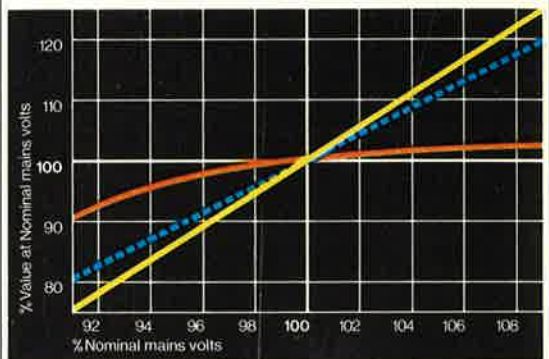

Mains Voltage Variation

Diagram 2 shows the effect of mains voltage variation on light output, lumens per watt and lamp watts.

Run-up Characteristics

These are shown in diagram 3. The time taken will vary slightly depending on the location and the type of fitting housing the lamp. Curves for metal halide lamps are shown in diagram 4.

3/ Typical mercury run-up curves

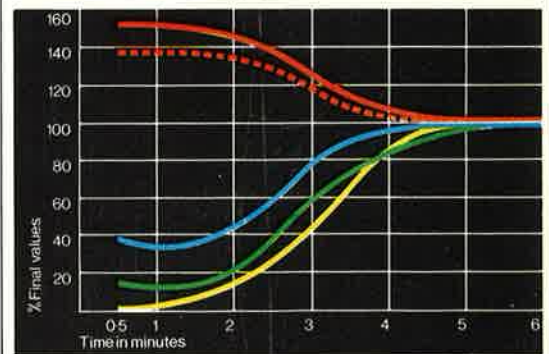

Standards

Lamps conform to the following standards where applicable:

British

BS. 3677: High Pressure Mercury Vapour Lamps  
BS. 98: 1962 Screw Caps and Holders

International

IEC publication 188 High Pressure Mercury Vapour Lamps

4/ Typical metal halide run-up curves

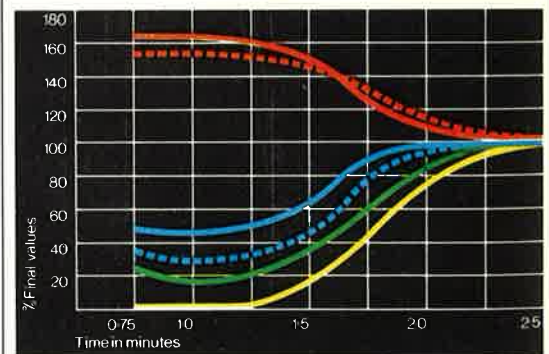

Lumens per watt

Lamp Volts

Lamp Current

Lamp Watts

Supply Current

Supply Volts

Light Output

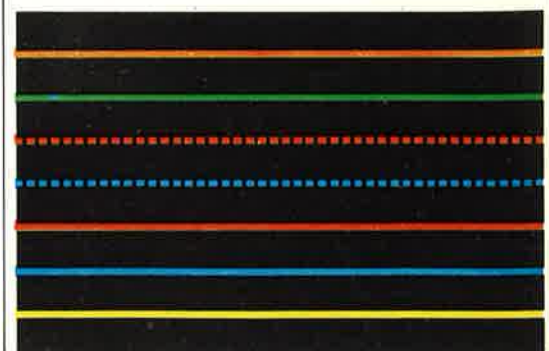

# Sodium lamp information

Lighting Design Lumens

Mains Voltage Variation

Run-up Characteristics

Standards

British

International

The Lighting Design Lumens quoted are the lamp outputs at 3000 hours (2000 hours for SON) and represent an average over the first 6000 hours life.

Diagrams 1 and 2 show the effect of the variation of mains voltage on light output, lumens per watt, supply watts and supply current.

For low pressure lamps these vary between 10 and 20 minutes according to type but there is no delay in starting if the lamp is switched on while hot. Typical run-up curves for linear lamps are shown in diagram 3.

Run up characteristics of SON lamps are shown in diagram 4.

Run-up characteristics of SOX lamps are shown in diagram 5.

Lamps described in this catalogue conform to the following standards where applicable:

BS. 3767: Low Pressure Sodium Vapour Lamps

IEC publication 192 Low Pressure Sodium Vapour Lamps

1/ Effect of variation of mains voltage on sodium lamp characteristics

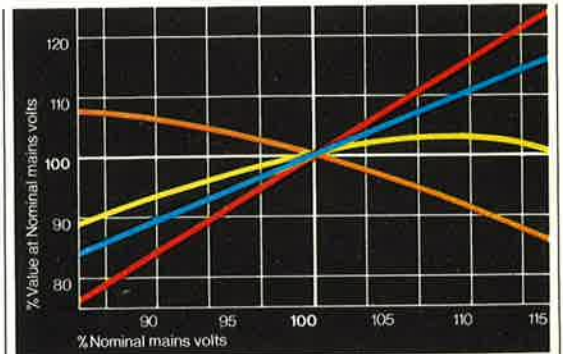

2/ Effect of variation of mains voltage on high pressure sodium lamp characteristics

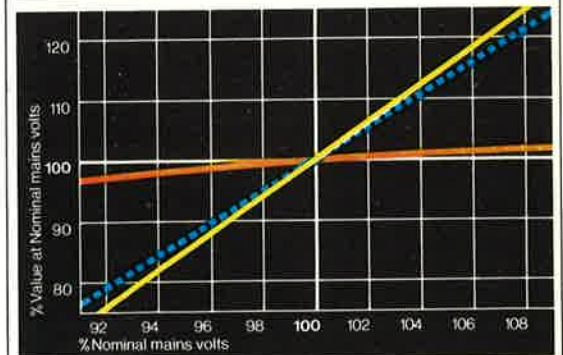

3/ Typical Linear Sodium run-up curves

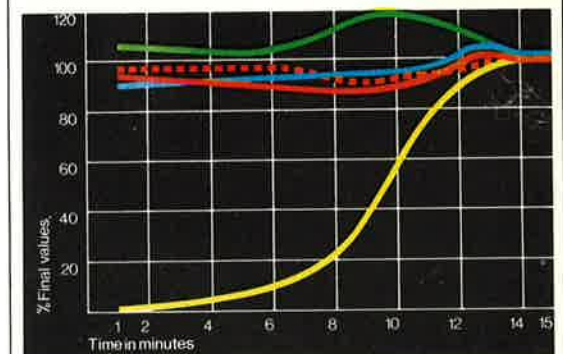

4/ Typical SON run-up curves

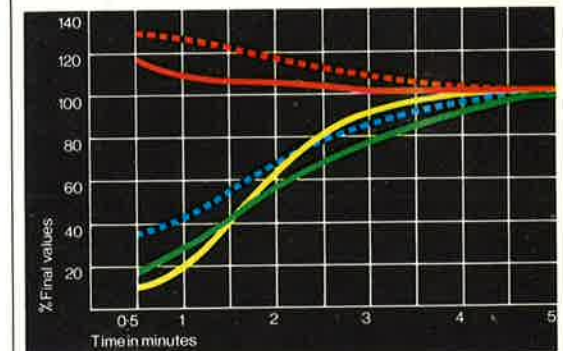

5/ Typical SOX run-up curves

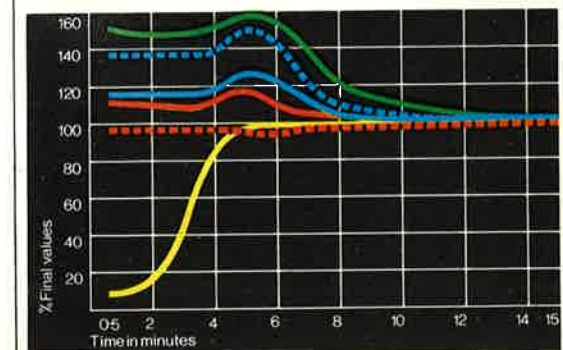

# Kolorarc Spectral Distribution

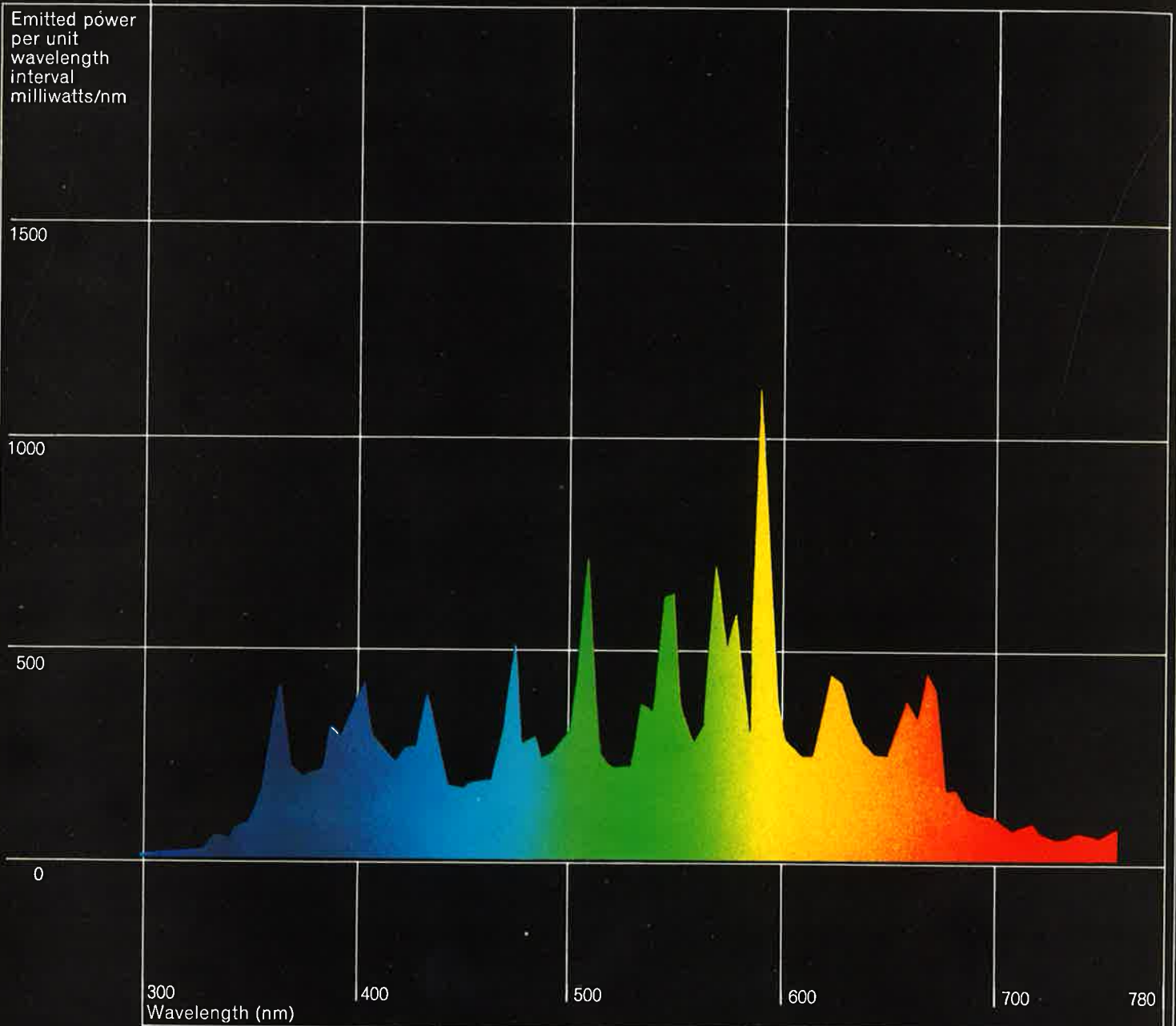

Percentage  
Luminance  
in Spectral  
Bands  
(400W Lamps)

Band	Waveband (nm)	Colour	% Luminance Standard MBI	% Luminance MBIF Kolorarc
1	380-420	Far violet	0.03	0.02
2	420-440	Violet	0.24	0.18
3	440-460	Blue	0.30	0.27
4	460-510	Blue green	5.55	8.96
5	510-560	Green	41.10	34.80
6	560-610	Yellow	46.00	47.00
7	610-660	Light red	6.66	8.24
8	660-760	Dark red	0.15	0.56

## Kolorarc MBIF and MBI metal halide lamps

### Description

High pressure discharge in mercury with metallic additives operating in a quartz arc tube. Kolorarc (MBIF) lamps have hard glass elliptical bulbs coated on the interior surface with fluorescent phosphor increasing the light output, improving the colour and diffusing the arc. MBI lamps have clear hard glass elliptical bulbs. The special additives in the arc help provide a more continuous spectral power distribution throughout the visible spectrum. At the same time the mercury resonance lines are reduced in comparison with ordinary mercury lamps, giving a light source with excellent colour rendering properties comparable to a Natural fluorescent tube.

### Application

In any situation where high light output must be combined with good colour rendering, Kolorarc lamps are ideal. They can be used indoors for offices, shops, supermarkets and stores, where colour is of primary importance, and are finding increasing application for illuminating interior sports halls, gymnasias and swimming pools. The excellent colour rendering of Kolorarc makes it suitable for museums and exhibitions where

skilled lighting design can enhance the beauty of the exhibits.

Industrially, Kolorarc lamps can be used in area and high-bay lighting where good colour qualities, coupled with high output efficiency, are required: Kolorarc lamps are 30% more efficient than MBF colour corrected mercury lamps. The high lumen output is of primary importance where the weight of fittings on the ceiling is a serious consideration. MBI lamps, with clear outer bulbs, are suitable where precise optical control is required, such as floodlighting. Kolorarc and MBI lamps have proved suitable light sources for use with colour television cameras. Other varieties of metal halide lamps are being increasingly used for stadia floodlighting, especially that of football grounds.

### Supply Voltage

200/250V

### Rated Life

7500 hours

### Burning Position

BU: Base up lamps must **not** be operated with cap more than 15° below horizontal.  
BD: Base down lamps must **not** be operated with cap more than 15° above horizontal.

### Range

MBIF Kolorarc

MBI

Watts	Supply Voltage	Nominal Lamp Voltage	Lamp Current Amps	Cap	Lighting Design Lumens*	Standard Pack
400	200/250	120/150	3.3	E40	27000	9
1000	200/250	235/265	4.2	E40	85000	1
400	200/250	120/150	3.3	E40	24000	9
1000	200/250	235/265	4.2	E40	78000	1

\*Applies to vertical position, when operated horizontally reduce by 10%.

Watts mm  
400 292  
1000 410

Watts mm  
400 122  
1000 167

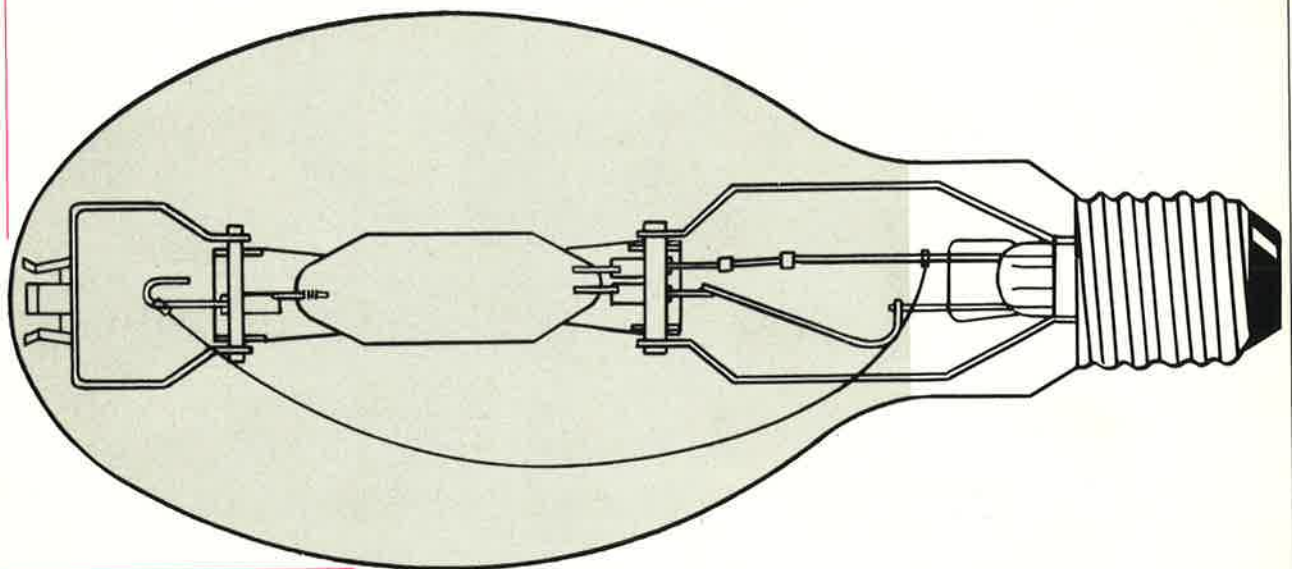

## Kolorarc MBIF and MBI metal halide lamps

Left/ Servicing Atlas Kolorlux and Kolorarc fittings in BEA's hangar at London Airport.

Right/ A Batley carpet warehouse lit by Atlas Kolorarc lamps.



A mixture of the old and the new: Atlas Kolorarc lamps illuminate the past at the new Hendon Aircraft Museum.



Left/ Prestige buildings come to life at night with Atlas discharge floodlighting.



Right/ Atlas Kolorarc provides a high level of illumination in the new amusement area at Skegness.



Atlas Kolorarc illuminate the combined gym and assembly hall at Bridgend Comprehensive School.



# Kolorlux MBF Spectral Distribution

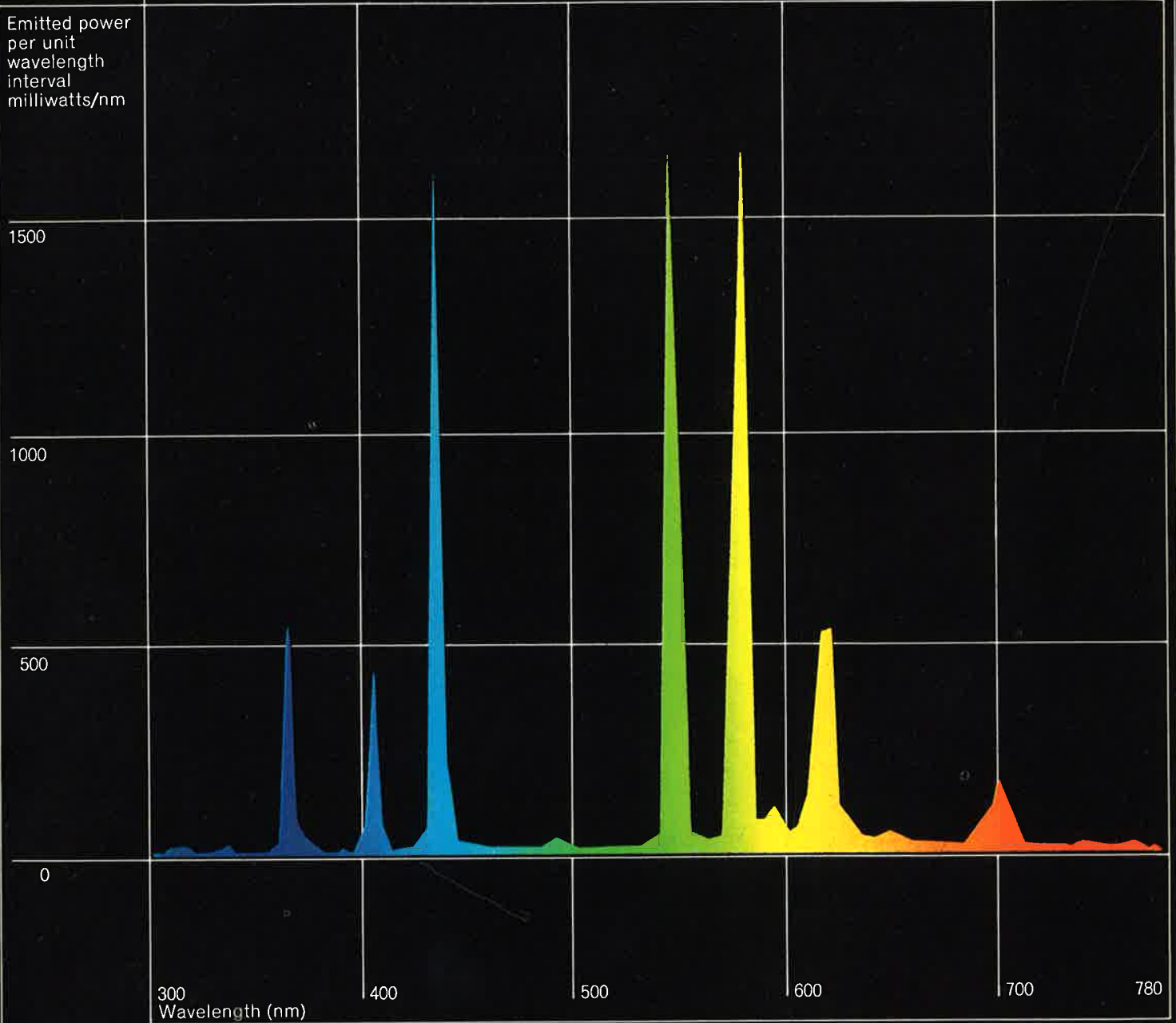

Percentage  
Luminance  
in Spectral  
Bands  
(400W Lamp)

Band	Waveband (nm)	Colour	% Luminance
1	380-420	Far Violet	0.01
2	420-440	Violet	0.44
3	440-460	Blue	0.08
4	460-510	Blue Green	0.67
5	510-560	Green	37.7
6	560-610	Yellow	47.3
7	610-660	Light red	13.7
8	660-760	Dark red	0.12

## Kolorlux MBF mercury fluorescent lamps

### Description

High pressure mercury vapour discharge operating in a quartz arc tube. The interior surface of the elliptical bulb is coated with a fluorescent phosphor which converts ultra-violet radiation from the discharge into visible light. Kolorlux lamps employ a new phosphor giving up to 10% higher light output than standard MBF lamps together with improved colour at the red end of the spectrum.

commercial and display lighting, shopping centre and concourse lighting, and area floodlighting. In comparison with fluorescent tubes higher output Kolorlux lamps need fewer fittings for an equivalent illumination level: so that your ceiling is tidier – and your maintenance costs are slashed.

### Applications

MBF lamps are widely used in industrial lighting and streetlighting. The improved colour of Kolorlux has extended the applications to

### Supply Voltage

200/250V

### Burning Position

Universal: lamps may be operated in any position.

### Range

Watts	Supply Voltage	Nominal Lamp Voltage	Lamp Current Amps	Cap	Lighting Design Lumens	Standard Pack
50	200/250	85/105	0.61	ES	1800	50
80	200/250	105/130	0.80	ES*	3350	24
125	200/250	110/140	1.15	ES*	5550	24
250	200/250	115/145	2.15	GES	12000	9
400	200/250	120/150	3.20	GES	21500	9
700	200/250	125/155	5.60	GES	38000	1
1000	200/250	130/160	7.50	GES	54000	1

\*3 pin BC cap also available.

Watts	mm	Watts	mm
50	129	400	286
80	154	700	328
125	175	1000	410
250	227		

Watts	mm
50	56
80	71
125	76
250	91
400	122
700	143
1000	167

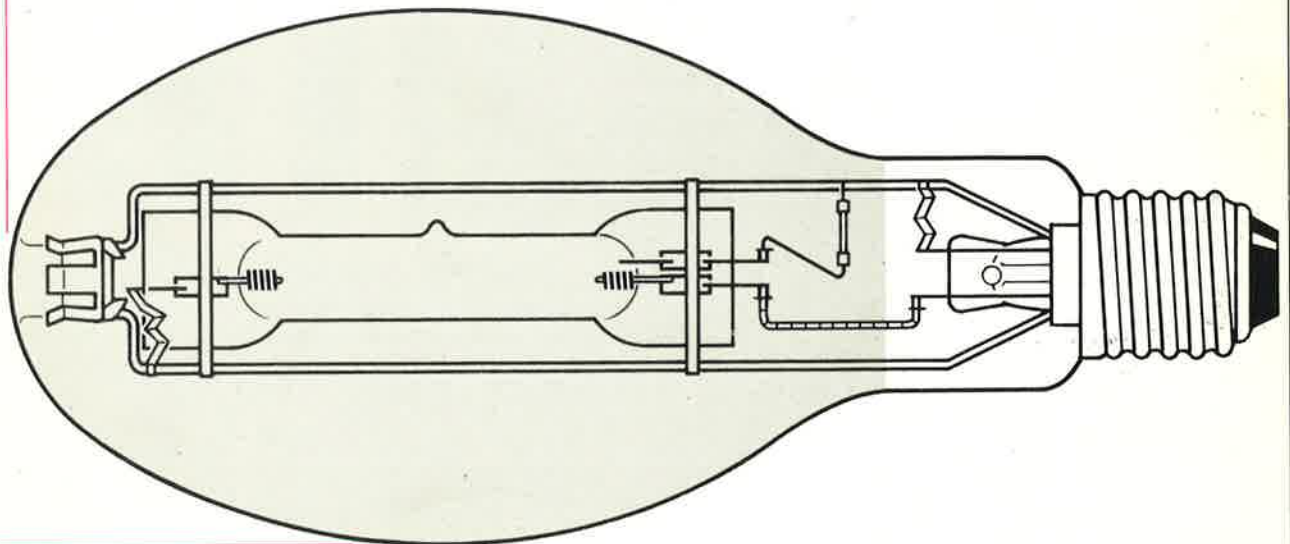

# Kolorlux MBFR Spectral Distribution

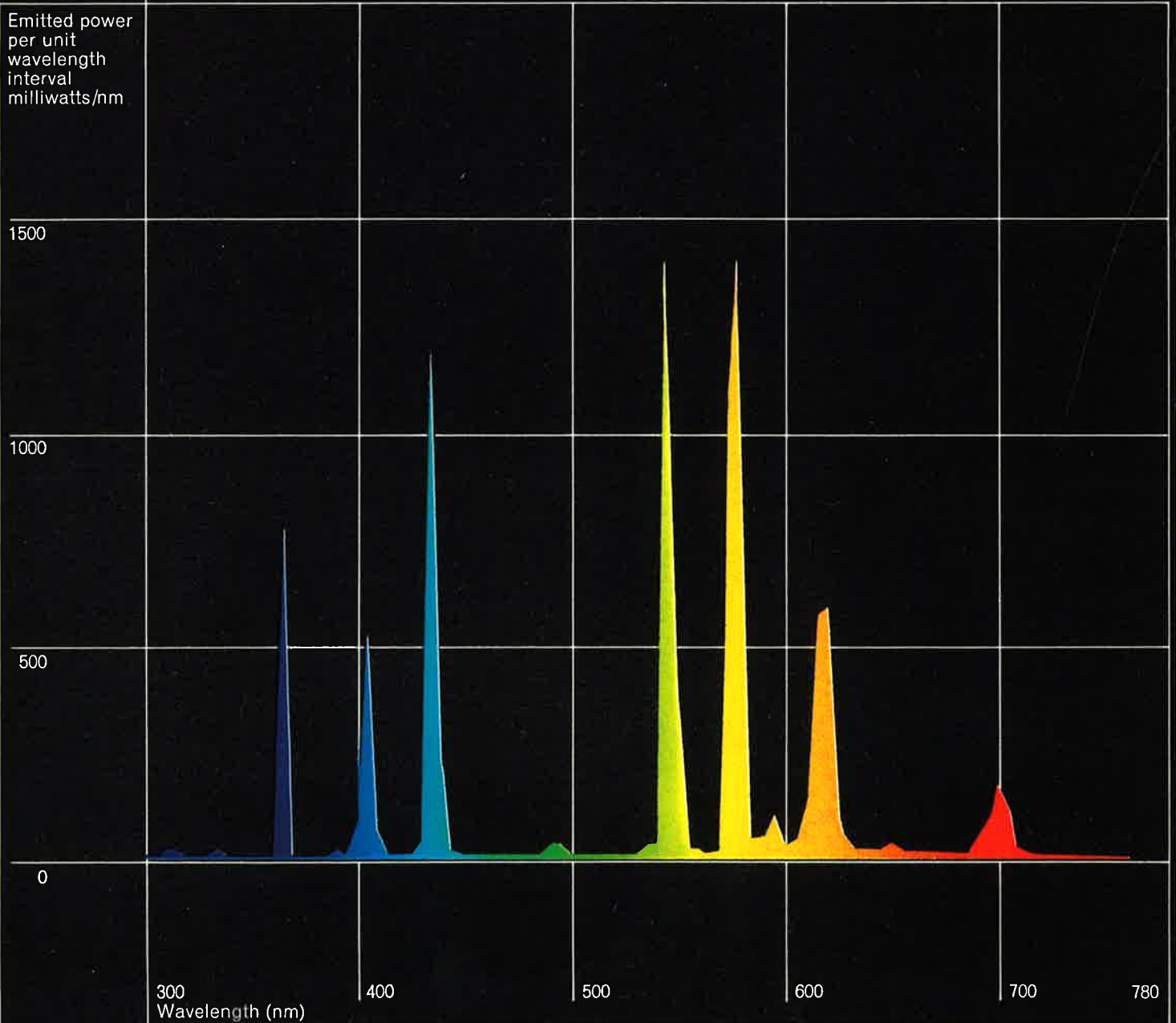

Percentage  
Luminance  
in Spectral  
Bands  
(400W Lamps)

Band	Waveband (nm)	Colour	% Luminance
1	380-420	Far violet	0.01
2	420-440	Violet	0.48
3	440-460	Blue	0.10
4	460-510	Blue green	0.71
5	510-560	Green	37.9
6	560-610	Yellow	49.3
7	610-660	Light red	11.4
8	660-760	Dark red	0.10

## Kolorlux MBFR mercury reflector lamps

### Description

High pressure mercury vapour discharge operating in a quartz arc tube. A shaped outer bulb forms an integral reflector. The upper portion of the bulb is coated with a reflecting layer which directs most of the light downward but allows some upward light. This internal reflector is unaffected by atmospheric corrosion and dirt collection so that the lamp requires the minimum maintenance. The introduction of Kolorlux phosphor into the range of reflector lamps gives a greatly improved colour and up to 10% higher output than previously available with standard MBFR lamps.

### Application

Kolorlux reflector lamps are particularly suitable for medium and high bay lighting. The hard glass outer bulb allows the lamps to be used in exposed conditions for area lighting. The improved colour of Kolorlux has widened the use of reflector lamps into commercial applications such as display lighting.

### Supply Voltage

200/250V

### Burning Position

Universal:  
lamps can be operated in any position.

### Range

Watts	Supply Voltage	Nominal Lamp Voltage	Lamp Current Amps	Cap	Lighting Design Lumens	Standard Pack
250	200/250	115/145	2.15	GES	10500	1
400	200/250	120/150	3.20	GES	18000	1
700	200/250	125/155	5.60	GES	32500	1
1000	200/250	130/160	7.50	GES	48000	1

Watts	mm
250	260
400	300
700	328
1000	380

Watts	mm
250	166
400	181
700	202
1000	221

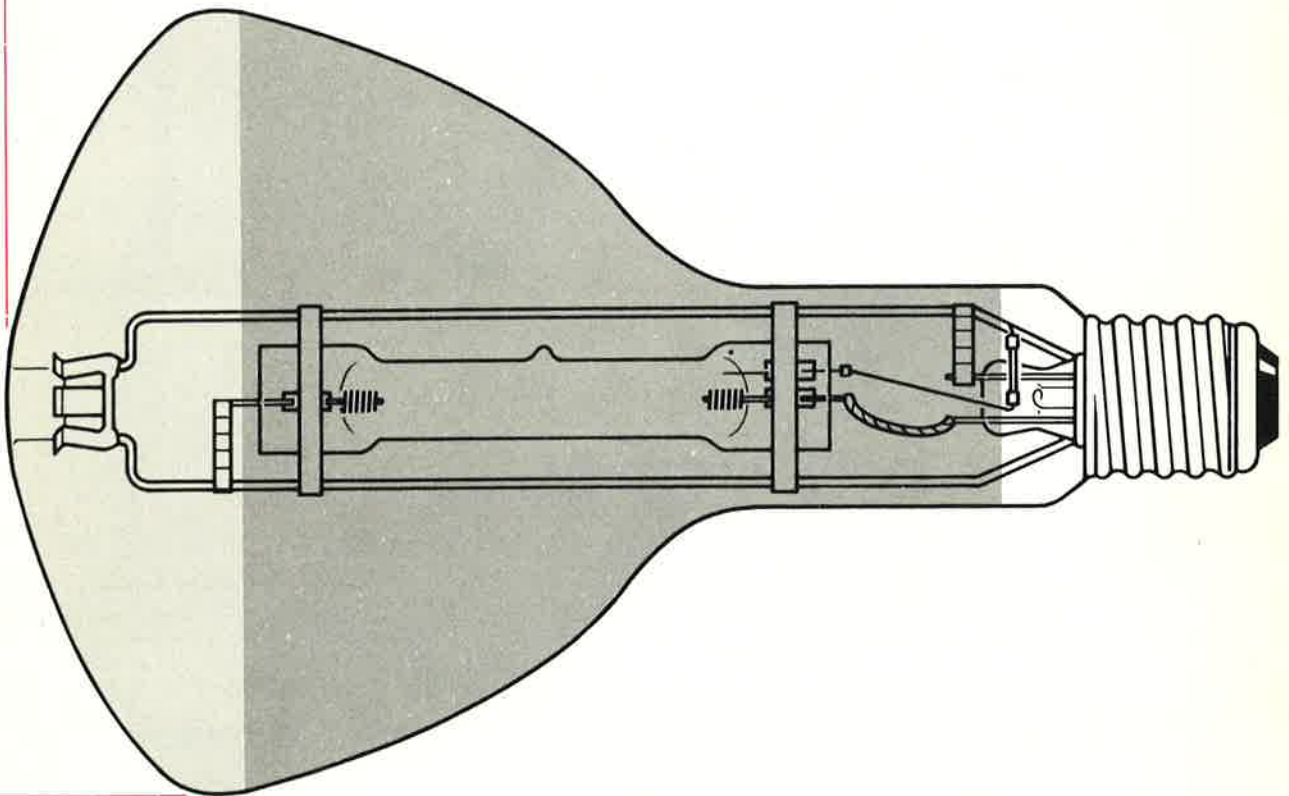

## Kolor-Plus MBTF and 'Black Light' MBTW mercury tungsten lamps

### Description

Mercury tungsten lamps consist of a high pressure mercury discharge in a quartz arc tube. Mounted coaxially with the arc tube and connected in series with it is a coiled tungsten filament which provides light and colour correction to the output of the mercury discharge and acts as a ballast to the arc.

No control gear is needed. Mercury tungsten lamps operate direct from the supply. All ratings have elliptical outer bulbs.

Kolor-Plus MBTF lamps (illustrated below) have an outer bulb coated with a new phosphor giving higher light output and improved colour.

The MBTW lamp has a pear shaped 'Black Light' outer bulb (length 184mm diameter 91mm) which effectively obscures all visible radiation, and emits long wave Ultra Violet.

### Application

Kolor-Plus MBTF lamps can be used as direct replacements for tungsten filament lamps giving higher light output and longer life. They are particularly suitable where labour costs are high and access is difficult. Applications include shop windows, garages, warehouses, streetlighting and in wellglass and flameproof fittings.

### Range

MBTF

MBTW

Watts	Supply Voltage	Lamp Current Amps	Cap	Lighting Design Lumens	Standard Pack
160	220/230	0.70	BC or ES	2700	24
160	240/250	0.65	BC or ES	2700	24
250	220/230	1.10	GES	4840	9
250	240/250	1.05	GES	4840	9
500	220/230	2.20	GES	11500	9
500	240/250	2.10	GES	11500	9
175	240/250	0.67	BC	-	12

### Advantages

The MBTW lamp is a very convenient way of providing Ultra Violet lighting ('Black Light') for fluorescent effects in dance halls, clubs, discotheques, parties etc.

Kolor-Plus MBTF lamps

- offer six times the life of GLS lamps
- plug directly into the mains: no need for control gear
- give a large proportion of their light output immediately after switch-on
- give greater lumen output than equivalent GLS lamps
- save labour costs on replacement.

### Supply Voltage

Kolor-Plus MBTF is available in two voltage ratings, 220/230V and 240/250V, and the MBTW in 240/250V only. The lamps must be operated on the correct supply. Sudden reductions in voltage may cause them to extinguish.

### Rated Life

MBTF—6000 hours  
MBTW—1500 hours

### Burning Position

Kolor-Plus and MBTW lamps are designed for operation in the cap up position; 250 and 500W ratings may be operated in other positions provided there is negligible fluctuation in the supply voltage.

Watts mm  
160 175  
250 227  
500 286

Watts mm  
160 76  
250 91  
500 122

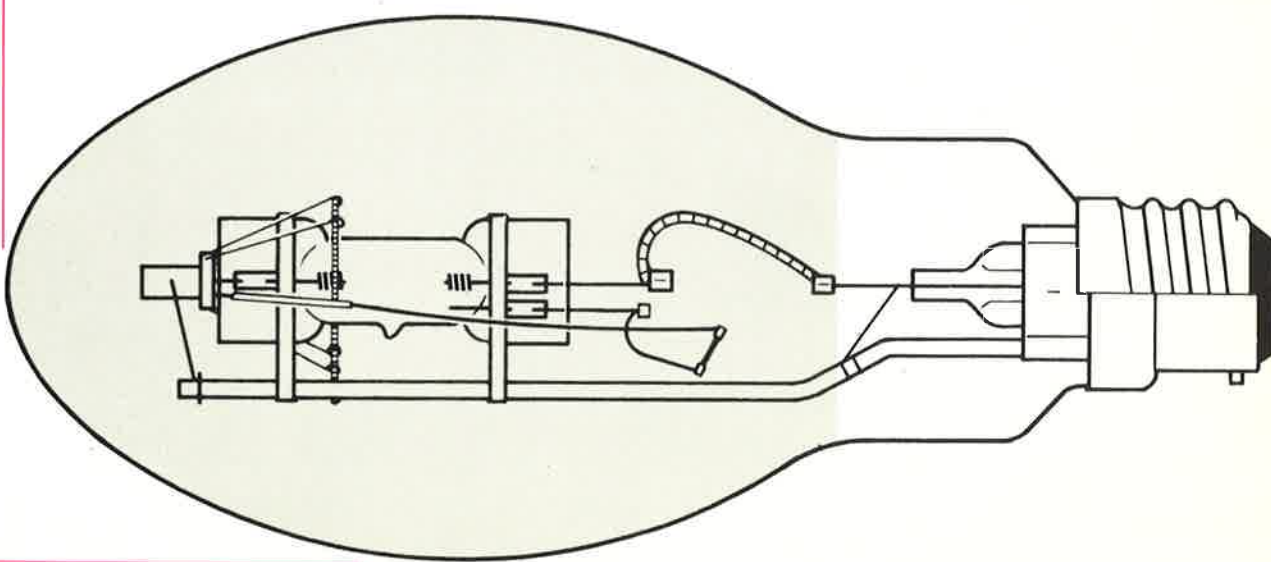

## MB mercury lamps

### Description

High pressure mercury vapour discharge operating in a quartz arc tube. The 80 and 125W have elliptical pearl bulbs, the 250 and 400W ratings have clear tubular hard glass bulbs.

### Application

MB lamps have been largely superseded for industrial and streetlighting by MBF Kolorlux with its higher light output and improved colour. MB lamps are still used, however, for general

illumination where colour is not important and also where the typical characteristics of mercury spectral power distribution are advantageous, e.g. for graphic arts, laboratory and scientific purposes, plant growth, floodlighting.

### Supply Voltage

200/250V

### Burning Position

Universal: lamps can be operated in any position.

### Range

Watts	Supply Voltage	Nominal Lamp Voltage	Lamp Current Amps	Cap	Lighting Design Lumens	Standard Pack
80	200/250	105/130	0.80	ES*	3200	24
125	200/250	110/140	1.15	ES*	5200	24
250	200/250	115/145	2.15	GES	11500	12
400	200/250	120/150	3.20	GES	19600	12

\*3 pin BC cap also available.

### Percentage Luminance in Spectral Bands (400W Lamp)

Band	Waveband (nm)	Colour	% Luminance
1	380-420	Far violet	0.02
2	420-440	Violet	0.61
3	440-460	Blue	0.18
4	460-510	Blue green	0.83
5	510-560	Green	47.7
6	560-610	Yellow	49.7
7	610-660	Light red	0.84
8	660-760	Dark red	0.07

Watts mm  
250 298  
400 338

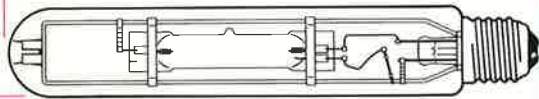

Watts mm  
250 52  
400 52

Watts mm  
80 154  
125 175

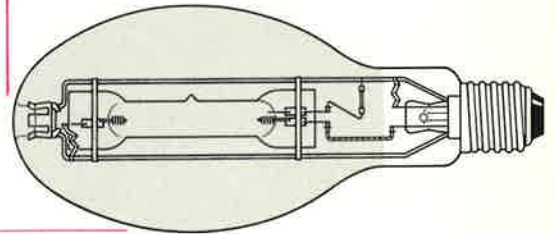

Watts mm  
80 71  
125 76

## Kolorlux MBF and MBFR

Left/ Kolorlux is used to illuminate the interior of the world's oldest wood-constructed church—St. Andrews Greenstead in Essex.

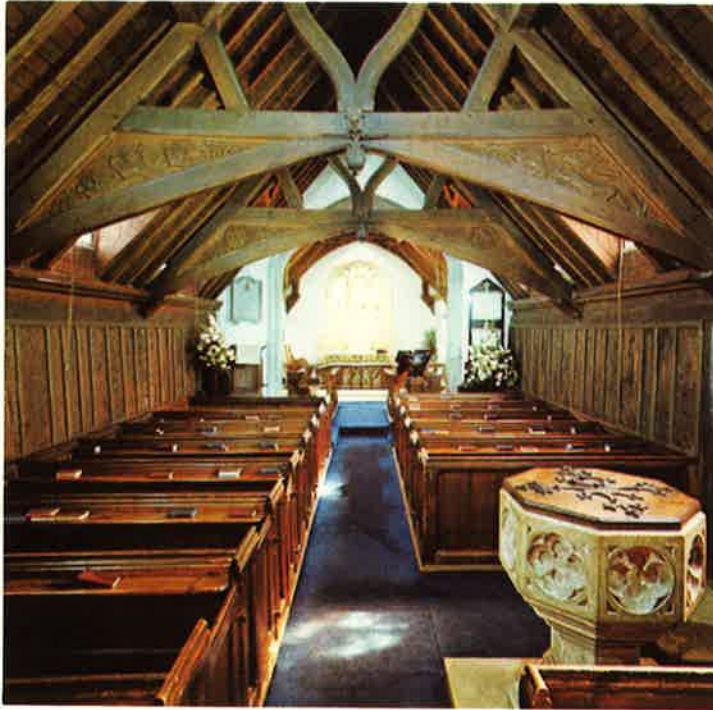

Right/ When Swedish precision engineers Motala Verkstad relit their plant, they chose Atlas Kolorlux.

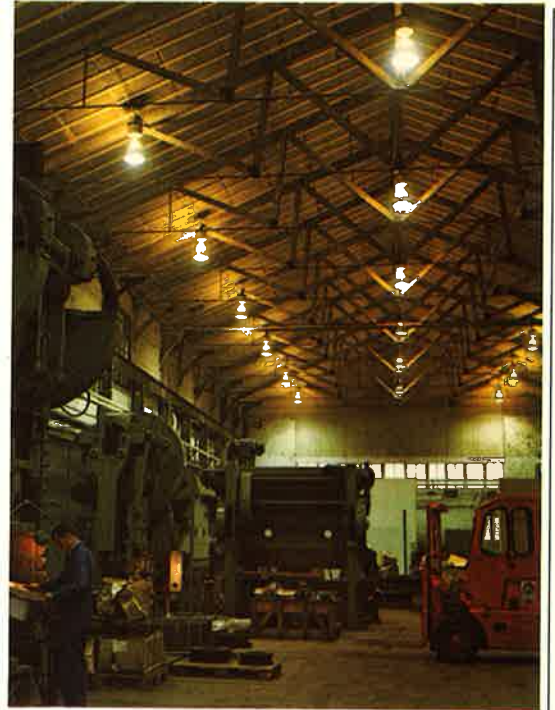

Strathclyde University's Wolfson Centre employs Atlas Kolorlux lamps in this uniquely-designed coffer ceiling treatment.



Left/ Kolorlux packs light, the Capitol Theatre, Horsham in Sussex.



Right/ The plant room of John Player's new 'Horizon' factory at Nottingham lit by Kolorlux.



Fully recessed modular Atlas Kolorlume fittings, each housing a Kolorlux lamp provide aesthetically pleasing lighting in this Tesco store.



# KolorSON Spectral Distribution

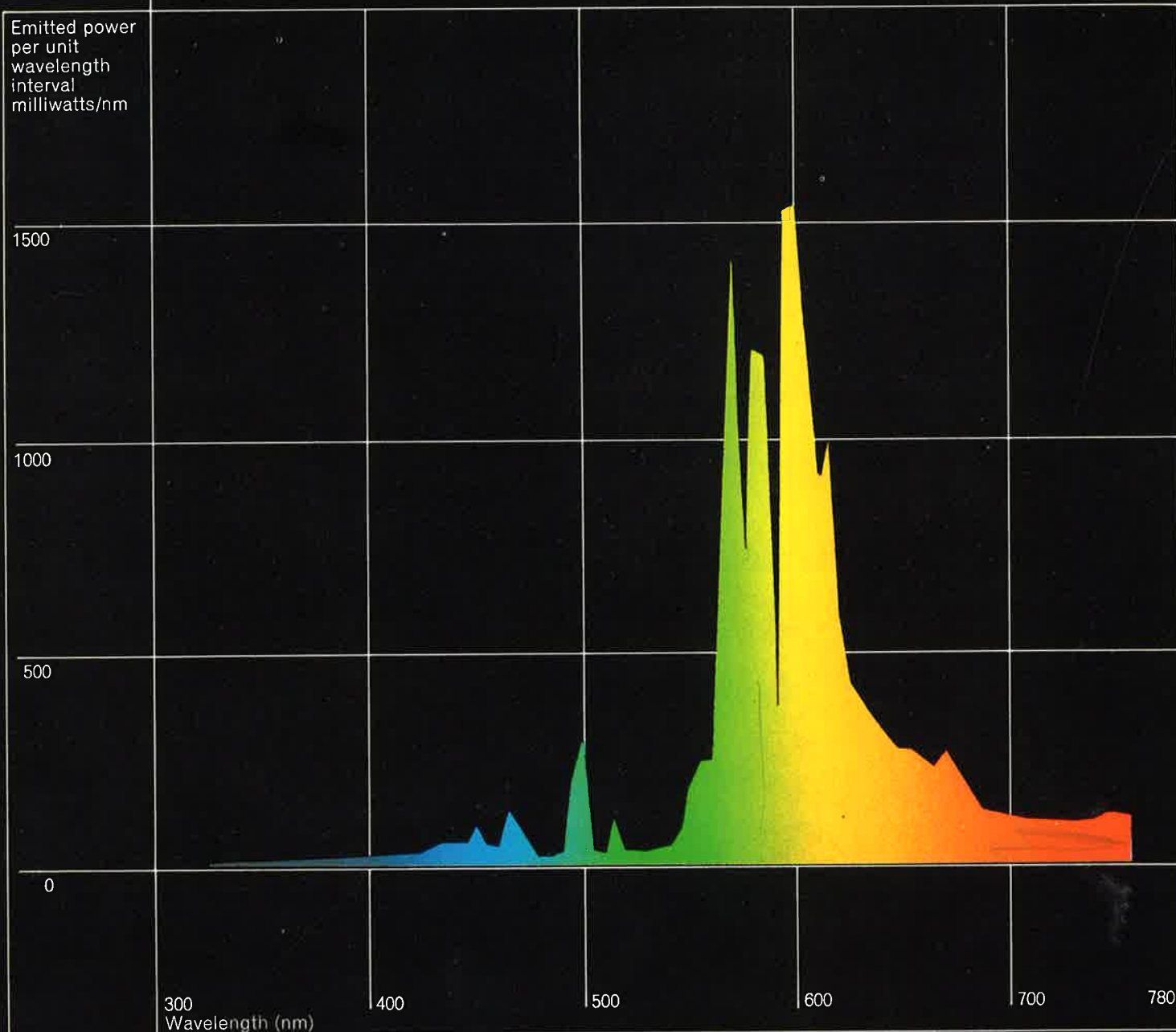

Percentage  
Luminance  
in spectral  
Bands  
(400W Lamps)

Band	Waveband (nm)	Colour	% Luminance
1	380-420	Far violet	0.002
2	420-440	Violet	0.021
3	440-460	Blue	0.083
4	460-510	Blue green	1.95
5	510-560	Green	7.56
6	560-610	Yellow	77.1
7	610-660	Light red	12.9
8	660-760	Dark red	0.372

## KolorSON high pressure sodium lamps

### Construction

The high-pressure sodium lamp differs from other discharge lamps in that it employs an arc tube made of sintered aluminium oxide. This material is necessary to withstand the intense chemical activity of sodium vapour at high temperature and pressure. Metal caps are sealed to its ends and support the electrodes, and the tube is mounted in a robust frame which locates on a depression in the crown of the bulb to give great strength and optical control.

The elliptical hard glass outer tube has a diffusing coating and the GES cap is locked on to the moulded neck to eliminate any possibility of the lamp becoming detached from the cap during life. The lamp has the same dimensions and luminance ratio as an MBF mercury lamp so that it can be used in the same fittings (different control gear is required). Tubular 250 and 400W SON/T versions are also available with a clear bulb for floodlighting purposes.

### Starting and Operation

The lamp is started by a high-voltage pulse applied by an ignitor which ceases to function once the arc has struck. The ignitor may be mounted up to 13.5m/44ft from the lamp. External starting simplifies lamp construction, ensures immediate striking and is very reliable. The lamp takes four or five minutes to run up to full brightness. KolorSON lamps will normally restrike within one minute of extinction and rapidly regain full light output. This is a most important feature for interior use and a considerable improvement on the restriking times of mercury lamps.

### Colour

The colour appearance of the lamp resembles that of a black body at 2100°K – a pleasant golden white. When the arc is run up the monochromatic yellow characteristic of low-pressure sodium lamps disappears and is replaced by a broader distribution across the visible spectrum. This gives acceptable colour rendering with a warm appearance and, although blues and greens are somewhat subdued, reds and yellows are enhanced and all colours are easily distinguishable.

### Applications

Public lighting: traffic routes, city centres, shopping areas.  
 Area lighting: airports, dockyards, car parks, forecourts.  
 Floodlighting: stadiums, buildings, marshalling yards, sports grounds. Interior lighting: high-bay lighting for factories, warehouses, hangars, halls.  
 The Department of the Environment have recommended that high pressure sodium lamps be used for street lighting in conservation areas, both in the country and the town.

### Rated Life

6000 hours

### Guaranteed Life

4000 hours

### Supply Voltage

200/250

### Burning Position

Universal: lamps may be operated in any position.

### Range

Watts/Type	Supply Voltage	Nominal Lamp Voltage	Lamp Current Amps	Cap	Lighting Design Lumens	Standard Pack
250 Tubular	200/250	100	3.0	GES	22500	12
250 Elliptical	200/250	100	3.0	GES	21000	9
400 Tubular	200/250	105	4.4	GES	42000	12
400 Elliptical	200/250	105	4.4	GES	40000	4

Watts mm  
 250 256  
 400 286

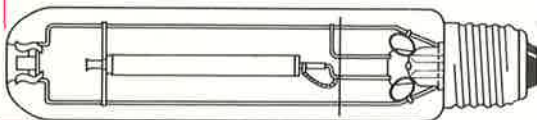

Watts mm  
 250 53  
 400 53

Watts mm  
 250 227  
 400 286

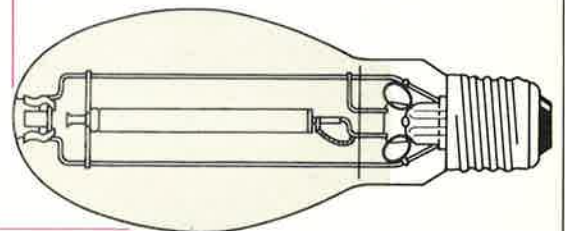

Watts mm  
 250 91  
 400 122

## Linear SLI/H sodium lamps

### Quality and Reliability

Since the introduction of the 140W linear sodium lamp by Thorn in 1966, it has achieved an unrivalled record of reliability. Installations throughout the country (including the first motorway lighting on the M4) have given fewer failures before relamping than any other type of sodium lamps to date. Statistical records show lamp survival to be more than 95% at the end of the rated life of 6000 hours.

Thorn's improved 200W HO linear sodium lamp offers higher lumen output for 200W installations. Light output is increased by 10% to 27,500 lumens. This is achieved by the incorporation of a redesigned arc tube and a new improved reflected coating based on indium.

Braided cathodes as used in the 140W lamp are embodied to give reliable life and freedom from earlier failures.

The 200W HO lamp can be used in all existing 200W installations except early switch-start circuits for which the standard 200W is still available.

### Research and Development

The shape of the inner tube contributes materially to the success of this lamp. In order to minimise energy losses due to atomic collisions and absorption of light by the sodium atoms themselves, the tube volume must be kept as small as possible, but its surface must be large in order to achieve a high light output. By careful design of the discharge tube cross section these apparently diametrically opposed conditions are satisfied and in addition there is direct linear path between the electrodes of the lamp which helps to achieve a low starting voltage.

The lamp requires a sodium reservoir temperature of approximately 250°C to give optimum vapour pressure for efficient light radiation and a portion of the power to the tube is used to achieve this. The use of an infra-red reflecting film on the inside of the outer bulb, composed of the oxides of metals such as tin and indium, conserves the thermal energy of the arc, thus increasing the proportion of energy available to produce light.

The thickness of this film is strictly controlled to

### Special Advantages

give optimum transmission of the visible D-line sodium radiation ensuring maximum light output. Its electrical resistance is such that by connecting it on to one cathode, it acts as a secondary starting electrode.

The electrical characteristics and low starting voltage of the 140W lamp are designed for use on standard control gear used for 90W SOX and obsolete 140W integral ratings, giving completely reliable operation under normal and adverse conditions.

The small source size and uniform distribution of both the 140W and 200W ratings conform to the design requirements of modern streetlighting lanterns. Light is emitted uniformly from an arc 780mm long and only 29mm wide.

The compact and lightweight construction makes it easy to handle during relamping. The lamp is 908.8mm/3ft long and 39.5mm/1.5in in diameter and weighs less than 0.45kg/1lb. Transport and installation are further simplified by a 25-way pack which can easily be stored in service truck or tower wagon.

### Spectral Distribution

The discharge has a characteristic yellow colour, almost all the visible energy being concentrated at 589/589.6 nm.

### Application

The primary application for linear sodium lamps is for streetlighting where their outputs are suitable for the DoE requirements for principle and trunk roads, and motorways. The construction of the lamp materially assists in the optical design and shape of lanterns to meet illuminance distribution and environmental criteria.

### Rated Life

6000 hours

### Guaranteed Life

4000 hours

### Supply voltage

200/250V

### Burning Position

The lamps must operate in a horizontal position  $\pm 20^\circ$

### Range

Watts	Supply Voltage	Nominal Lamp Voltage	Lamp Current Amps	Lighting Design Lumens	Standard Pack
140	200/250	175	0.9	20000	25
200	200/250	135	1.6	25000	25
200 (HO)	200/250	145	1.55	27500	25

Watts	mm
140	908.8
200	908.8
200HO	908.8

Watts	mm
140	39.5
200	39.5
200HO	39.5

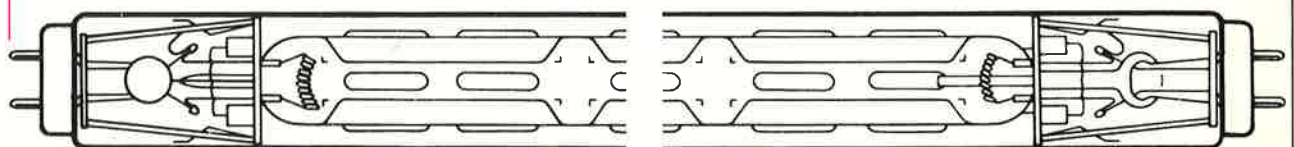

## SOX sodium lamps

### Description

Low pressure sodium discharge operating in a U-shaped arc tube. The U-tube is enclosed in a tubular outer bulb which has a reflector coating on the inside surface to provide thermal insulation. This construction provides a lamp of considerably higher efficacy than the Integral type which is now obsolete. A BC cap is fitted.

### Application

The primary application for SOX lamps is for streetlighting where their higher efficacy has superseded earlier types as follows:  
 1/ The 90W SOX lamp replaces the 140W SOI/H integral lamp and the 140W SO/H lamp and jacket. All three lamps have the same dimensions and can be operated from the same control gear.  
 2/ The 55W SOX lamp replaces the 85W SOI/H integral lamp and 85W SO/H lamp and jacket. All three lamps have the same dimensions and can be operated from the same control gear.

3/ The 35W SOX lamp replaces the 60W SOI/H integral lamp and the 60W SO/H lamp and jacket. All three lamps have the same dimensions and can be operated from the same control gear.

4/ The 35W SOX lamp is also electrically interchangeable with the 45W SOI/H integral lamp and 45W SO/H lamp and jacket. Although the 35W SOX is longer than 45W SOI/H and SO/H it can be used as a replacement in lanterns originally designed for 45/60W SOI/H and SO/H.

**Rated Life** 6000 hours

**Guaranteed Life** 4000 hours

**Supply Volts** 200/250

**Burning Position** Horizontal  $\pm 20^\circ$ .  
 The 35W and 55W ratings may also be operated in the vertical cap up position.

### Range

Watts	Supply Voltage	Nominal Lamp Voltage	Lamp Current Amps	Lighting Design Lumens	Standard Pack
35	200/250	70	0.6	4500	9
55	200/250	104	0.59	7500	9
90	200/250	112	0.94	12500	9
135	200/250	164	0.95	21500	9
180	200/250	245	0.90	31500	9

Watts	mm
35	311
55	425
90	528
135	775
180	1120

Watts	mm
35	53
55	53
90	67
135	67
180	67

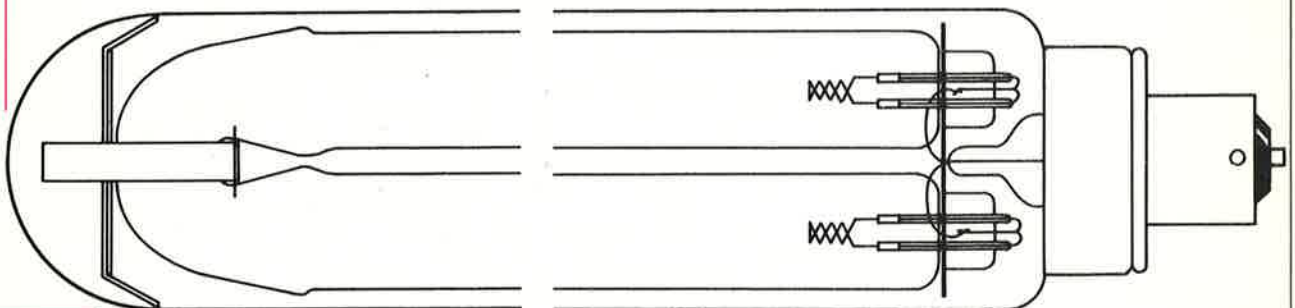

## KolorSON high pressure sodium lamps

Atlas KolorSON is ideal for industrial areas especially active warehouses and stock depots.



Guildford by-pass lit by Atlas KolorSON high pressure sodium.



## Linear SLI/H sodium lamps

Atlas Linear  
Sodium lamps  
illuminate the  
A45 Coventry  
to Birmingham  
Road.



**Circuit components**  
**50W, 80W, 125W and 250W**  
**MBF and MBFR Kolorlux**  
**mercury discharge lamps**

Control Gear  
 240V 50Hz  
 Ballast

Lamp Wattage	Circuit Diagram††	Catalogue Number	Weight Kg(lb)	Filling	Illustrated Type/ Can Colour	Terminals
50	301	G.53184.4†	1.2 (2.75)	Polyester resin	K/White	Screw
80	301	G.53162.4*	1.8 (4)	Polyester resin	DV/White	Screw
125	301	G.53159.4*	2.72 (6)	Polyester resin	DT/White	Screw
250	301	G.53198.4*‡	2.54 (5.6)	Polyester resin	DT/White	Screw

Capacitor

Lamp Wattage	Circuit Diagram	Catalogue Number	Capacitance µF	Working Voltage	Fused or Unfused	Terminals
50	301	G.C2203†	6±10%	250	Fused	Solder tags
80	301	G.C2234	8±10%	250	Unfused	Flying leads
125	301	G.C2234	8±10%	250	Unfused	Flying leads
250	301	G.C2214	13±10%	250	Unfused	Flying leads

Other Ballast Ratings  
 220V 50Hz

Lamp Wattage	Circuit Diagram	Catalogue Number	Illustrated Type	Can Colour	Weight Kg (lb)	Voltage Tappings
50	301	G.53188.2†	K	White	1.2 (2.75)	—
80	301	G.53176.2†	R1	White	1.36 (3)	—
125	301	G.53134.2†	R2	White	1.87 (4.2)	—
250	301	G.53198.2†*	DT	White	2.54 (5.6)	—
80	301	G.53162.T	DV	White	1.8 (4)	200/210,220/230, 240/250
125	301	G.53159.T	DT	White	2.72 (6)	200/210,220/230, 240/250
250	301	G.53158.T	DS	White	3.86 (8.5)	200, 210,220, 230, 240, 250

\*Units marked with British Standard Kitemark to BS.4782.

† For use in fittings only.

†† See page 27



‡ The heat dissipation from these ballasts is extremely efficient and it is therefore necessary to ensure that cables in close proximity to the ballast surface are high temperature grade or suitably protected by high temperature sleeving.

Control Gear  
 Type K

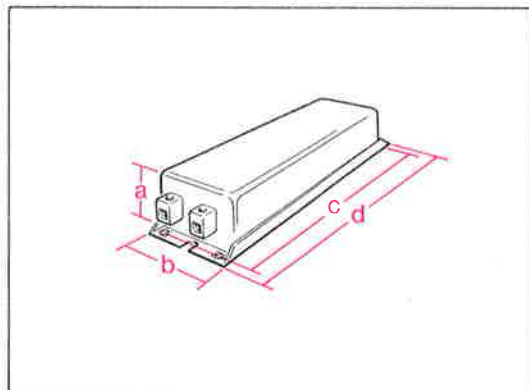

	a	b	c	d
mm	40	48	152	165
in	1.56	1.875	6.0	6.5

Type DT

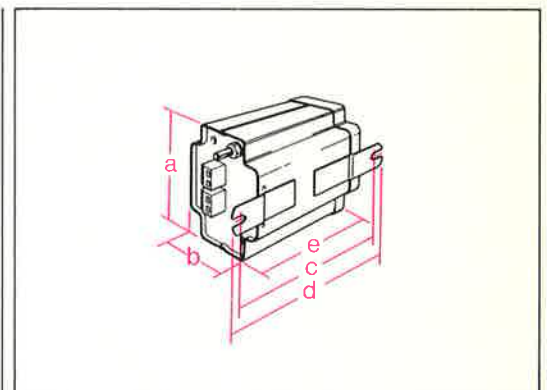

	a	b	c	d	e
mm	83	76	127	140	108
in	3.25	3.0	5.0	5.5	4.25

Type DV

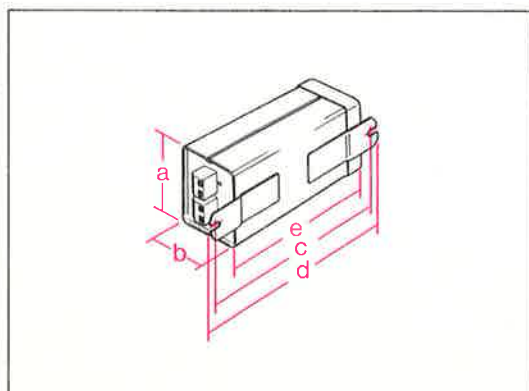

	a	b	c	d	e
mm	70	57	158	171	127
in	2.75	2.25	6.25	6.75	5.0

Type R1

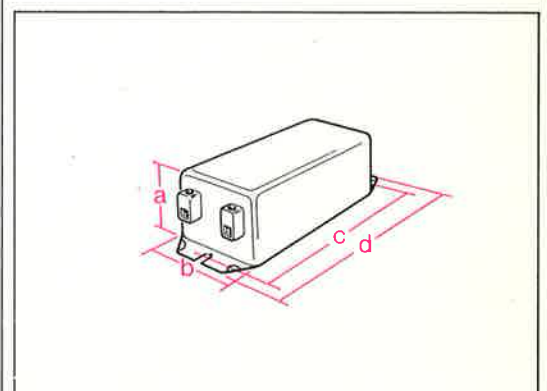

	a	b	c	d
mm	48	64	127	146
in	1.875	2.5	5.0	5.75

## Circuit components 400W, 700W and 1000W MBF and MBFR Kolorlux mercury discharge lamps

Control Gear  
240V 50Hz  
Ballast

Lamp Wattage	Circuit Diagram††	Catalogue Number	Weight Kg (lb)	Filling	Illustrated Type/ Can Colour	Terminals
400	301	G.53193.4*‡	3.86 (8.5)	Polyester resin	DS/White	Screw
700	306	G.53157.T	5.5 (12)	Polyester resin	DU/White	Screw
		+ G.53198.4*‡	2.54 (5.6)	Polyester resin	DT/White	Screw
1000	306	2 x G.53243.4*‡	3.86 (8.5) (each)	Polyester resin	DS/White	Screw

Capacitor

Lamp Wattage	Circuit Diagram	Catalogue Number	Capacitance $\mu$ F	Working Voltage	Fused or Unfused	Terminals
400	301	G.C2218	20 $\pm$ 10%	250	Unfused	Flying leads
700	306	G.C2218	20 $\pm$ 10%	250	Unfused	Flying leads
		+ G.C2214	13 $\pm$ 10%	250	Unfused	Flying leads
1000	306	2 x G.C2236	25 $\pm$ 10% (each)	250	Unfused	Flying leads

Other Ballast  
Ratings  
220V 50Hz  
200/250V 50Hz

Lamp Wattage	Circuit Diagram	Catalogue Number	Illustrated Type	Can Colour	Weight Kg (lb)	Voltage Tappings
400	301	G.53193.2†*	DS	White	3.86 (8.5)	—
400	301	G.53157.T	DU	White	5.5 (12)	200, 210, 220, 230, 240, 250
700	306	G.53157.T	DU	White	5.5 (12)	210, 220, 230, 240, 250
		+ G.53158.T	DS	White	3.86 (8.5)	210, 220, 230, 240, 250
1000	306	2 x G.53164.T	DU	White	5.5 (12) (each)	190, 200, 210, 220, 230, 240

\*Units marked with British Standard Kitemark to BS.4782.  
†† See page 27



‡ The heat dissipation from these ballasts is extremely efficient and it is therefore necessary to ensure that cables in close proximity to the ballast surface are high temperature grade or suitably protected by high temperature sleeving.

Type R2

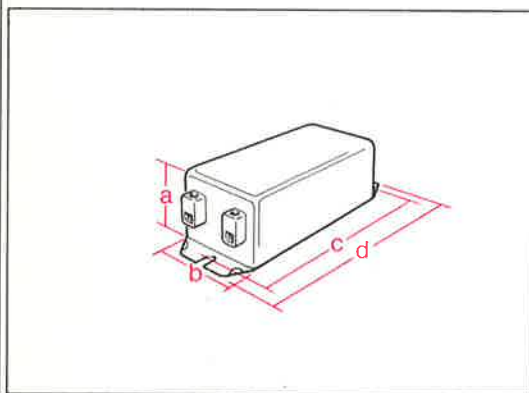

	a	b	c	d
mm	48	64	152	172
in	1.875	2.5	6.0	6.75

Tapping Table  
for Tapped  
Ballasts

Lamp Wattage	Ballast Catalogue Number	Supply Voltage/ Terminals
700	G.53157.T	210/2-3
		220/1-3
		230/2-4
		240/1-4
		250/2-5
	G.53158.T	210/1-3
		220/2-4
		230/1-4
		240/2-5
		250/1-5
1000	2 x G.53164.T	190/2-3
		200/1-3
		210/2-4
		220/1-4
		230/2-5
		240/1-5

Type DS

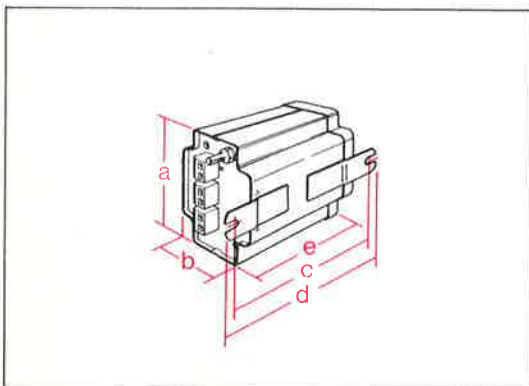

	a	b	c	d	e
mm	105	102	158	171	140
in	4.125	4.0	6.25	6.75	5.5

Type DU

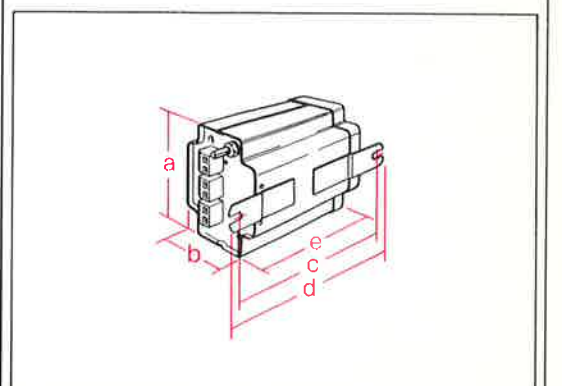

	a	b	c	d	e
mm	98	89	146	158	127
in	3.875	3.5	5.75	6.25	5.0

## Circuit components 400W and 1000W metal halide discharge lamps

Control Gear  
240V 50Hz  
Ballast

Lamp Wattage	Circuit Diagram	Catalogue Number	Weight Kg (lb)	Filling	Illustrated Type/ Can Colour	Terminals
400	315	G.53193.T	3.86 (8.5)	Polyester resin	DS/White	Screw
1000	311	G.53247.4††	24 (52.5)	Polyester resin	DP/Black	Flying leads

Capacitor

Lamp Wattage	Circuit Diagram	Catalogue Number	Capacitance $\mu\text{F}$	Working Voltage	Fused or Unfused	Terminals
400	315	G.C2218	$20.0 \pm 10\%$	250	Unfused	Flying leads
1000	311	4 x G.C2236**	$25 \pm 10\%$ (each)	250	Unfused	Flying leads

Ignitor

Lamp Wattage	Circuit Diagram	Catalogue Number	Weight Kg (lb)	Illustrated Type	Can Colour	Terminals
400	315	G.53262	0.51 (1.12)	DB	White	Leads

Other Ballast  
Ratings  
220V 50Hz

Lamp Wattage	Circuit Diagram	Catalogue Number	Weight Kg (lb)	Filling	Illustrated Type/ Can Colour	Terminals
1000	311	G.53247.2	24 (52.5)	Polyester resin	DP/Black	Flying leads

\*\* Connected in parallel.  
†† Uses ballast fixing bracket G.M6181

Control Gear  
Type DS

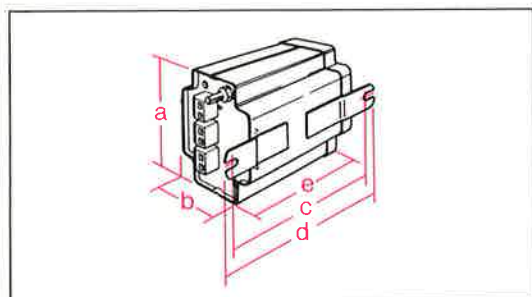

	a	b	c	d	e
mm	98	89	146	158	127
in	3.875	3.5	5.75	6.25	5.0

Type DZ

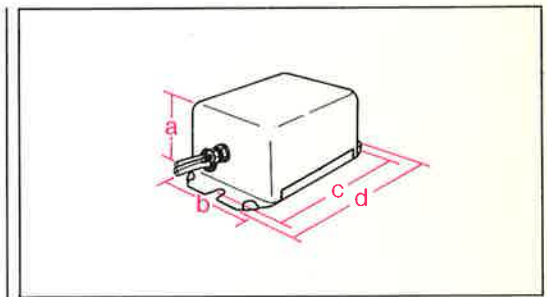

	a	b	c	d
mm	48	64	89	102
in	1.875	2.5	3.5	4.0

Type DP

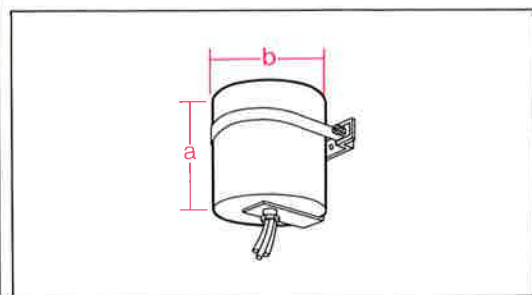

	a	b
mm	235	207
in	9.25	8.125

Type DB

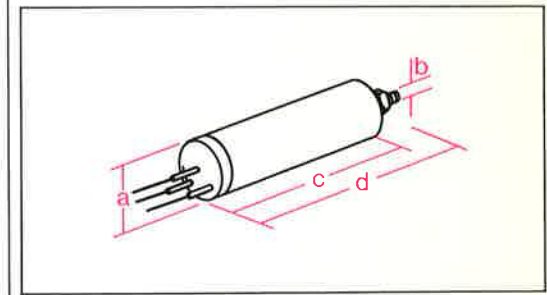

	a	b	c	d
mm	37	8	102	115
in	1.46	0.31	4.0	4.5

Type DU

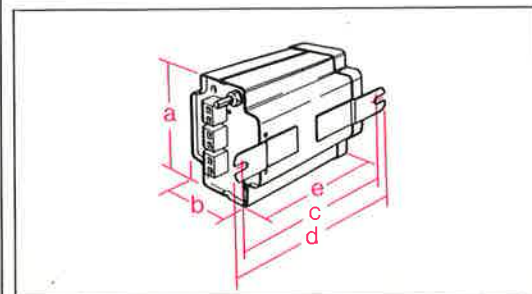

	a	b	c	d	e
mm	105	102	158	171	140
in	4.125	4.0	6.25	6.75	5.5

## Circuit components 250W and 400W SON high-pressure sodium discharge lamps

Control Gear  
240V 50Hz  
Ballast

Lamp Wattage	Circuit Diagram	Catalogue Number	Weight Kg (lb)	Filling	Illustrated Type/ Can Colour	Terminals
250	315A	G.53251.T‡	3.8 (8.5)	Polyester resin	DS/White	Screw
400	315A	G.53230.T‡	5.7 (12.55)	Polyester resin	DU/White	Screw

Capacitor

Lamp Wattage	Circuit Diagram	Catalogue Number	Capacitance $\mu\text{F}$	Working Voltage	Fused or Unfused	Terminals
250	315A	G.C2235	$30 \pm 10\%$	300	Unfused	Flying leads
400	315A	2 x G.C2218	$20 \pm 10\%$ (each)	250	Unfused	Flying leads

Ignitor

Lamp Wattage	Circuit Diagram	Catalogue Number	Weight Kg (oz)	Illustrated Type	Can Finish	Terminals
250	315A	G.53282	0.065 (2.3)	DB	Aluminium	Flying leads
400	315A	G.53282	0.065 (2.3)	DB	Aluminium	Flying leads

Other Ballast  
Ratings  
220V 50Hz

Lamp Wattage	Circuit Diagram	Catalogue Number	Weight Kg (lb)	Filling	Illustrated Type/ Can Colour	Terminals
250	315A	G.53251.T‡	3.8 (8.5)	Polyester resin	DS/White	Screw
400	315A	G.53230.T‡	5.7 (12.55)	Polyester resin	DU/White	Screw

‡ The heat dissipation from these ballasts is extremely efficient and it is therefore necessary to ensure that cables in close proximity to the ballast surface are high temperature grade or suitably protected by high temperature sleeving.

Circuit  
Diagrams

301/ Circuit for  
MBF and  
MBFR  
mercury  
discharge  
lamps

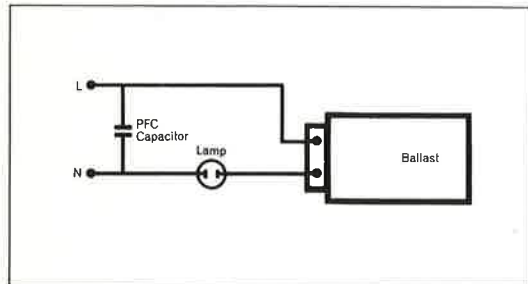

302/ Circuit for  
200W SLI/H  
sodium  
discharge  
lamp

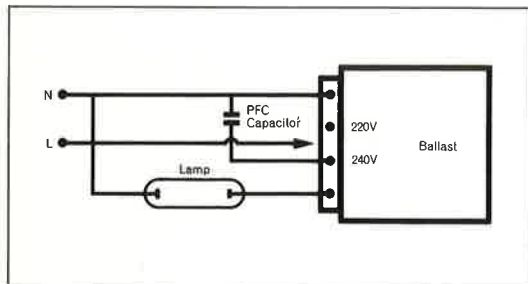

304/ Circuit for  
135W or 180W  
SOX sodium  
discharge  
lamp

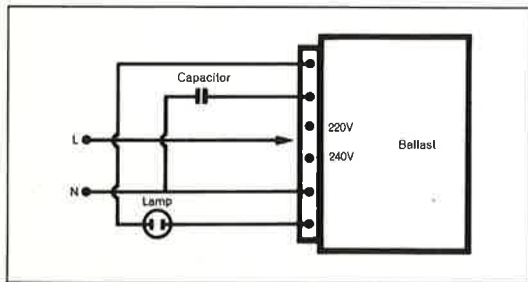

306/ Circuit for  
700W and  
1000W MBF  
and MBFR  
mercury  
discharge  
lamps

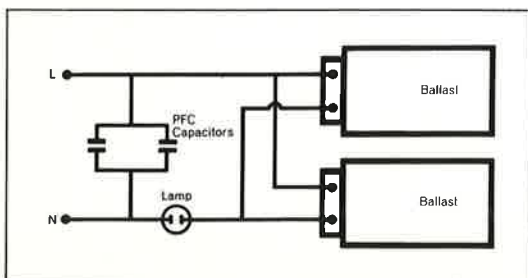

307/ Circuit for  
140W SO/H,  
SOI/H or SLI/H  
and 35/55/90W  
SOX

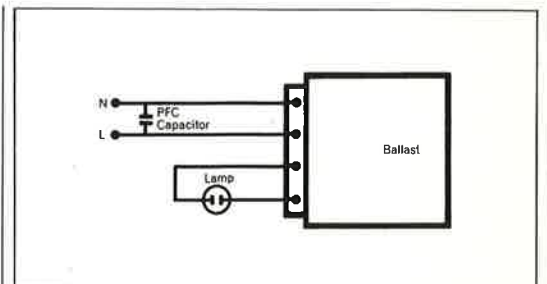

311/ Circuit for  
1000W metal  
halide  
discharge  
lamp

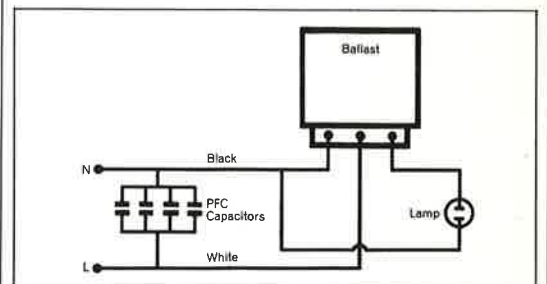

315/ Circuit for  
400W metal  
halide  
discharge  
lamp

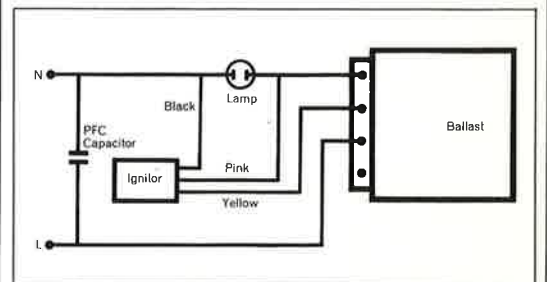

315A/ Circuit  
for 250W or  
400W SON  
high pressure  
sodium lamp

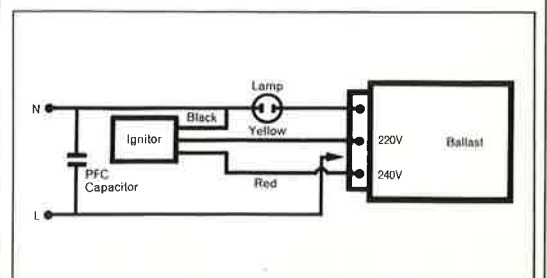

## Circuit components SO, SOI, SOX and SLI sodium discharge lamps

Control Gear  
240V 50Hz  
Ballast

Lamp and Wattage	Circuit Diagram††	Catalogue Number	Weight Kg (lb)	Filling	Illustrated Type/ Can Colour	Terminals
35, 55W SOX	307	G.53131.4*	4.1 (9)	Polyester resin	DJ/White	Screw
140W SO/H, SOI/H or SLI/H or 90W SOX	307	G.53232.4*	5.82 (12.6)	Polyester resin	DU/White	Screw
135W SOX or 180W SOX	304	G.53260.T*	6.55 (14.5)	Polyester resin	DY/White	Screw
200W SLI/H	302	G.53261.T*	6.55 (14.5)	Polyester resin	DY/White	Screw

Capacitor

Lamp and Wattage	Circuit Diagram	Catalogue Number	Capacitance $\mu\text{F}$	Working Voltage	Fused or Unfused	Terminals
35, 55W SOX	307	G.C2216	15 $\pm$ 10%	250	Unfused	Flying leads
140W SO/H, SOI/H or SLI/H or 90W SOX	307	G.C2218 (for 140W) G.C2236 (for 90W)	20 $\pm$ 10% (for 140W) 25 $\pm$ 10% (for 90W)	250	Unfused	Flying leads
135W SOX or 180W SOX	304	G.C2281	13 $\pm$ 5%	440	Unfused	Flying leads
200W SLI/H	302	G.C2355	35 $\pm$ 10%	250	Unfused	Flying leads

Other Ballast  
Ratings  
220V 50Hz

Lamp and Wattage	Circuit Diagram	Catalogue Number	Weight Kg (lb)	Filling	Illustrated Type/ Can Colour	Terminals
35, 55W SOX	307	G.53182.T	3.40 (7.5)	Polyester resin	DR/White	Screw
140W SO/H, SOI/H or SLI/H or 90W SOX	307	G.53232.2	5.82 (12.6)	Polyester resin	DU/White	Screw
135W SOX or 180W SOX	304	G.53260.T*	6.55 (14.5)	Polyester resin	DY/White	Screw
200W SLI/H	302	G.53261.T*	6.55 (14.5)	Polyester resin	DY/White	Screw
35, 55W SOX	307	G.53182.T	3.40 (7.5)	Polyester resin	DR/White	Screw

\* Units marked with British Standard Kitemark to BS.4782.

†† See page 27



Control Gear  
Type DU

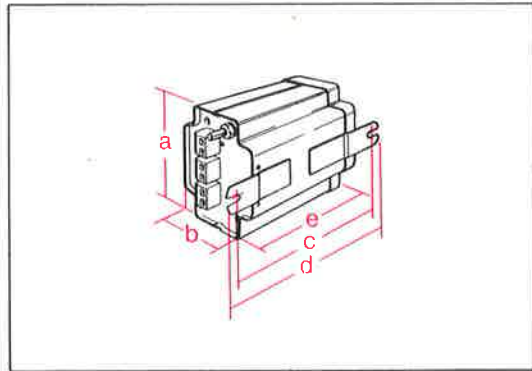

	a	b	c	d	e
mm	105	102	158	171	140
in	4.125	4.0	6.25	6.75	5.5

Type DY

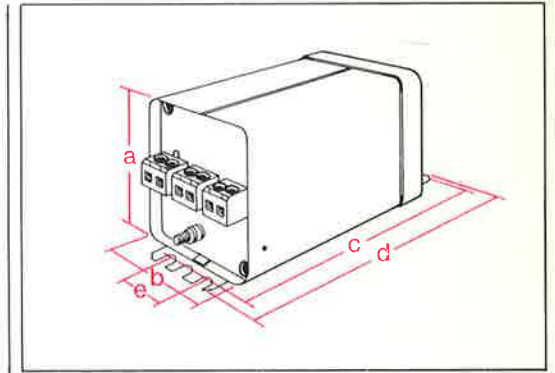

	a	b	c	d	e
mm	114	93	165	178	67
in	4.5	3.656	6.5	7.0	2.625

Type DJ

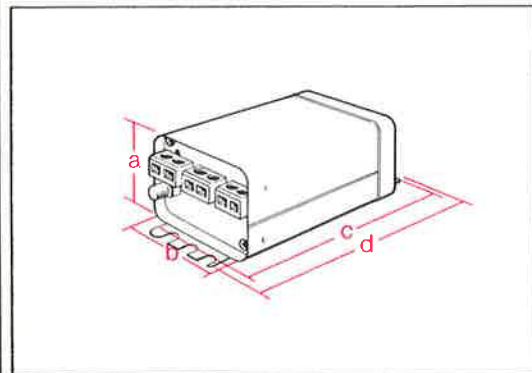

	a	b	c	d
mm	84	93	156	178
in	3.328	3.656	6.125	7.0

Type DR

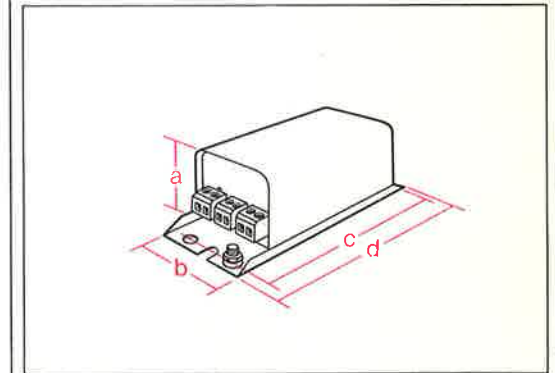

	a	b	c	d
mm	59	81	216	232
in	2.312	3.187	8.7	9.125

## Capacitors and capacitor clips for mercury and sodium discharge lamp circuits

This range of capacitors is unfused and suitable for continuous operation in the temperature range  $-40^{\circ}\text{C}$  to  $+70^{\circ}\text{C}$ . Fixing is by means of a removable saddle which clips vertically over the capacitor.

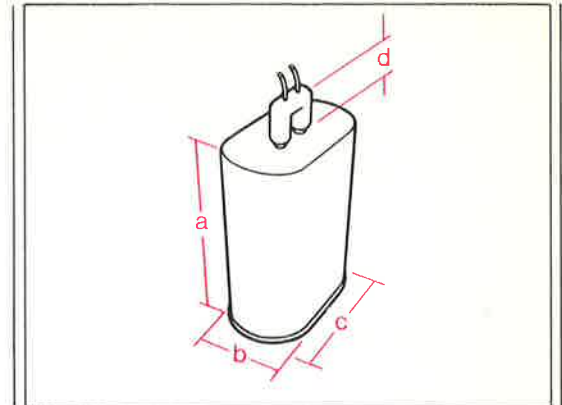

### Range

Catalogue Number	Capacitance $\mu\text{F}$	Working Voltage	a		b		c		d	
			mm	in	mm	in	mm	in	mm	in
AME C2203†	$6 \pm 10\%$	250	80	3.125	38	1.5	38	1.5	17.5	0.6875
AME C2234	$8 \pm 10\%$	250	70	2.75	35	1.375	54	2.125	17.5	0.6875
AME C2214	$13 \pm 10\%$	250	67	2.625	51	2	76	3	17.5	0.6875
AME C2281	$13 \pm 5\%$	440	105	4.125	51	2	76	3	17.5	0.6875
AME C2216	$15 \pm 10\%$	250	76	3	51	2	76	3	17.5	0.6875
AME C2288	$17.5 \pm 5\%$	350	137	5.375	51	2	76	2	17.5	0.6875
AME C2232	$18 \pm 10\%$	250	89	3.5	51	2	76	3	17.5	0.6875
AME C2278	$15 \pm 5\%$	350	121	4.75	51	2	76	3	17.5	0.6875
AME C2280	$16 \pm 10\%$	250	76	3	51	2	76	3	17.5	0.6875
AME C2218	$20 \pm 10\%$	250	92	3.625	51	2	76	3	17.5	0.6875
AME C2236	$25 \pm 10\%$	250	115	4.5	51	2	76	3	17.5	0.6875
AME C2355	$35 \pm 10\%$	250	108	4.25	63	2.5	89	3.5	17.5	0.6875

†For use in fittings only. This unit has solder tag terminals.

### Capacitor Clips

G.Y5292  
For  $54 \times 35\text{mm}$   
Capacitors

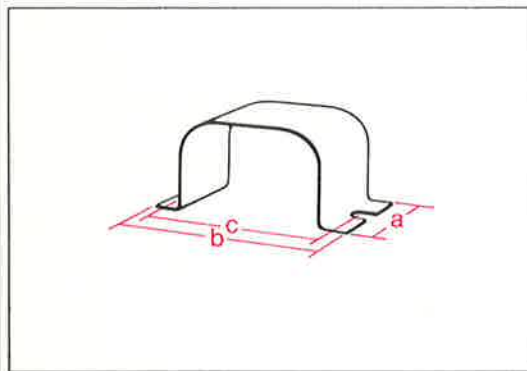

a		b		c	
mm	in	mm	in	mm	in
26	1	73	2.875	62	2.329

G.Y5293  
For  $89 \times 64\text{mm}$   
Capacitors

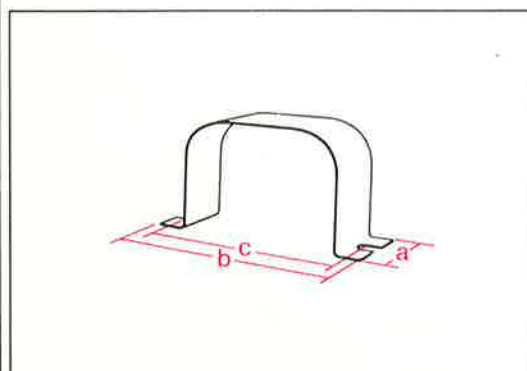

a		b		c	
mm	in	mm	in	mm	in
26	1	115	4.5	96	3.765

G.Y5279  
For  $76 \times 51\text{mm}$   
Capacitors

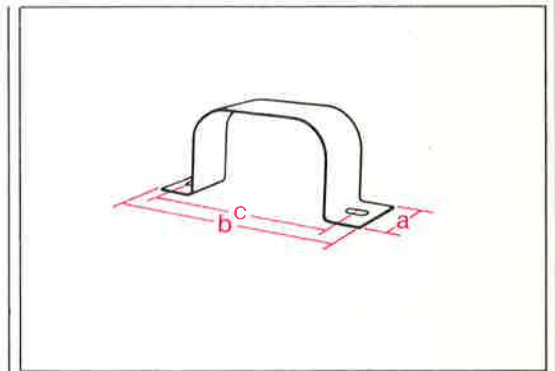

a		b		c	
mm	in	mm	in	mm	in
26	1	115	4.5	92	3.625

G.Y5242  
Universal  
Fixing  
Bracket for  
 $89 \times 63\text{mm}$  and  
 $76 \times 51\text{mm}$   
Capacitors

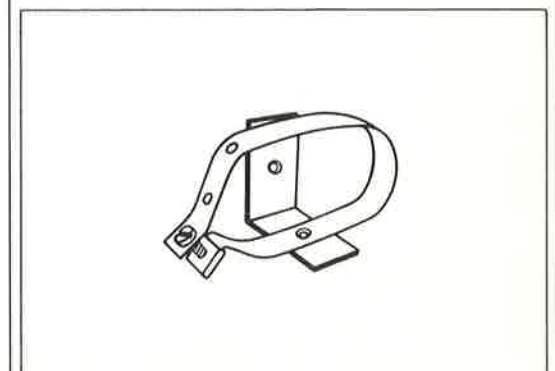

2BA fixing holes allow horizontal or vertical mounting.

## Control gear boxes

### Weatherproof Boxes for Exterior Use

These boxes are made of sheet steel finished stove enamel acrylic grey to BS2660 9-094. A weatherproof seal is effected between lid and box by means a closed cell neopene sponge gasket. Two  $2\frac{5}{32}$ in diameter holes are provided in one end of each box for supply and lamp connections. A wooden baseboard is fitted for control gear mounting and an earth terminal is available on one end.

These boxes are not supplied complete with control gear or terminal blocks.

G.M6174

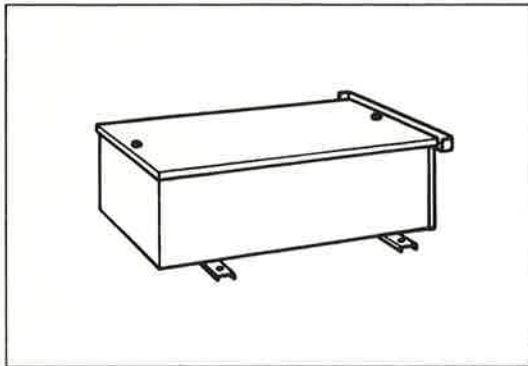

#### Internal Dimensions

Length	Width	Height
425mm(16.75in)	244mm(9.625in)	130mm(5.125in)

#### External Dimensions

Length	Width	Height
437mm(17.25in)	247mm(9.75in)	155mm(6.125in)

#### Fixing Centres

Fixing Centres	Weight
279 × 279 × 7.92mm diameter (11 × 11 × 0.31in diameter)	5.84kg (12.875lb)

G.M6172

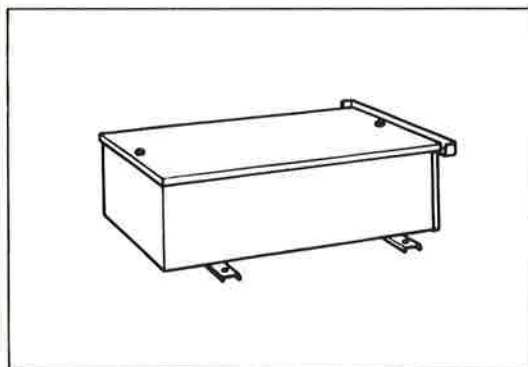

#### Internal Dimensions

Length	Width	Height
406mm(16.0in)	144mm(5.68in)	130mm(5.125in)

#### External Dimensions

Length	Width	Height
420mm(16.563in)	168mm(6.625in)	163mm(6.438in)

#### Fixing Centres

Fixing Centres	Weight
279 × 178 × 7.92mm diameter (11 × 7 × 0.31in diameter)	3.74kg (8.25lb)

G.M6169\*

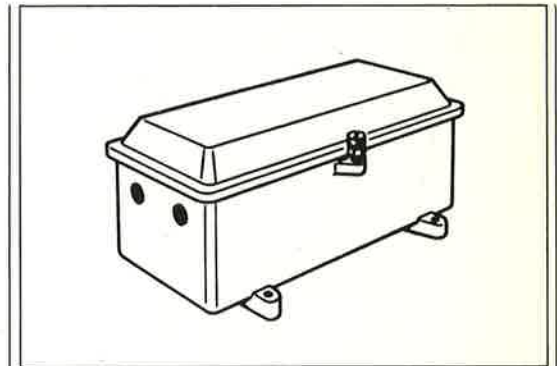

#### Internal Dimensions

Length	Width	Height
387mm(15.25in)	127mm(5.0in)	121mm(4.75in)

#### External Dimensions

Length	Width	Height
425mm(16.75in)	203mm(8.0in)	152mm(6.0in)

#### Weight

3.63kg (8.0lb)

\*This control gear box is made of high quality aluminium designed for exterior use to accommodate a large range of control gear.

## Control gear boxes

Remote Boxes  
for Interior Use

These boxes are made of sheet steel finished stove enamel acrylic grey to BS2660 9-094. Two  $2\frac{5}{32}$ in diameter holes are provided in one end of each box for supply and lamp connections to two-way 10A porcelain terminal blocks. A separate earth terminal is close to these blocks. Boxes are wired complete with 240V 50Hz HPF control gear.

RBG1000  
RBG700

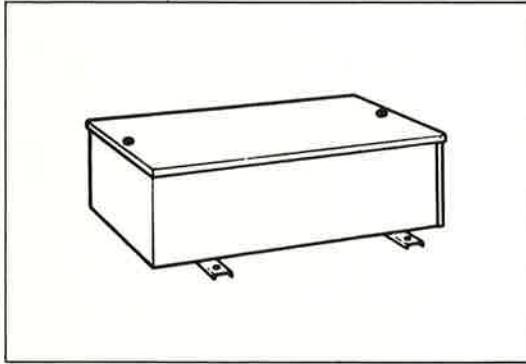

### External Dimensions

Length	Width	Height
425mm(17.06in)	247 mm(9.75in)	149mm(5.875in)

### Fixing centres

279 × 279 × 7.92mm diameter  
(11 × 11 × 0.31in diameter)

Gear Box	Weight		Control Gear
	kg	lb	
RBG1000	17.92	32.5	MBF
RBG700	13.95	30.75	MBF

RBG400  
RBIG400  
RBSG400  
RBG250  
RBSG250

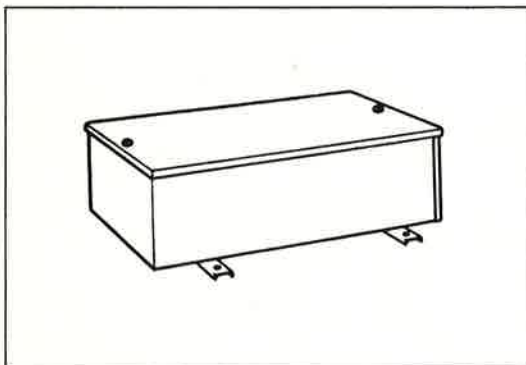

### External Dimensions

Length	Width	Height
416mm(16.375in)	157mm(6.18in)	149mm(5.875in)

### Fixing Centres

279 × 178 × 7.92mm diameter  
(11 × 7 × 0.31in diameter)

Gear Box	Weight		Control Gear
	kg	lb	
RBG400	8.05	17.688	400W MBF
RBIG400	8.59	18.938	400W MBI
RBSG400	8.17	18.0	400W SON*
RBG250	6.35	14.063	250W MBF
RBSG250	6.80	15.0	250W SON*

\*To special order only

Boxes for  
Interior Use  
With  
80/125W MBF  
Kolorlux Lamps

RBG125  
RBG80

Enclosed gear trays fitted with 240V 50Hz HPF control gear wired to a fused terminal block for incoming mains supply and a two-way terminal block for lamp connection. Boxes finished gloss white externally.

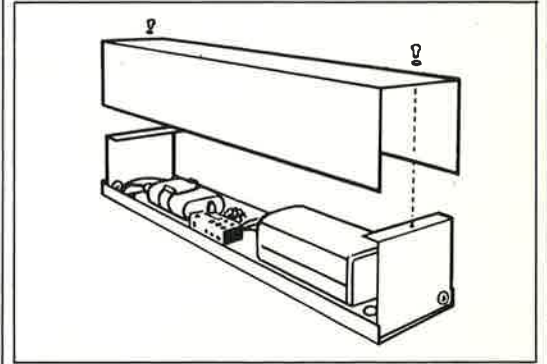

### External Dimensions

Length	Width	Height
337mm(13.25in)	92mm(3.625in)	83mm(3.25in)

### Fixing Centres

292 × 51mm(11.5 × 2in)

Gear Box	Weight		Control Gear
	kg	lb	
RBG125	3.63	8.0	125W MBF
RBG80	3.18	7.0	80W MBF

# THORN LIGHTING

A member of the Thorn Group

## Regional Headquarters

### London Region

Victoria Trading Estate  
Victoria Way, Charlton, London, SE7  
Telephone: 01.858 3281  
Telex: Thornlite Charlton 896171

### Eastern Region

Angel Road Works  
402 Angel Road, Edmonton, London, N18  
Telephone: 01.807 3050  
Telex: Thornlite Edmonton 23157

### South East Region

Thorn Industrial Estate  
Homesdale Road, Bromley, BR1 2QP, Kent  
Telephone: 01.460 9966  
Telex: Thornlite Bromley 25823

### South West Region

Thorn House  
Penarth Road, Cardiff, CF1 7YP  
Telephone: 0222.44200  
Telex: Thornlite Cardiff 49334

### Midlands Region

Thorn House, Saltley Trading Estate  
Aston Church Road, Saltley, Birmingham 8  
Telephone: 021.327 1535  
Telex: Thornlite Birmingham 33235

### North West Region

Thorn House, 2 Claytonbrook Road  
Clayton, Manchester, M11 1BP  
Telephone: 061.223 1322  
Telex: Thornlite Manchester 668642

### North East Region

Thorn House, 3 Ring Road  
Lower Wortley, Leeds 12  
Telephone: 0532.636321  
Telex: Thornlite Leeds 55110

### Scotland

Thorn House, Lawmoor Street  
Glasgow, G5 0TT  
Telephone: 041.429 6222  
Telex: Thornlite Glasgow 77630

### Northern Ireland

10 Severn Street, Belfast, BT4 1FB  
Telephone: 0232.56004/5, 51477/9  
Telex: Thornlite Belfast 74695

### Head Office and Showroom

Thorn House, Upper Saint Martin's Lane  
London, WC2H 9ED  
Telephone: 01.836 2444  
Telex: Thorn London 24184/5

## Overseas

### Australia

Thorn Lighting Industries (Pty) Limited  
Maldon Street,  
PO Box 74  
Broadmeadows  
Victoria 3047

### Austria

Thorn Electrical Industries GmbH  
1010 Wien  
Rosenbursenstrasse 8

### Canada

Thorn Lighting Canada Limited  
2763 Thamesgate Drive  
Malton  
Ontario

### Denmark

Thorn Electric A/S  
Fabriksparken 4  
2600 Glostrup

### Eire

Thorn Lighting Limited  
Grand Canal Place  
Dublin 8

### France

Thorn Electrique  
83 Rue Pierre Demours  
Paris 17eme

### Germany

Thorn Licht Beleuchtungsges. MBH  
2000 Hamburg 61  
Borsteler Chaussee 287

### Italy

Societa Industriale Vicentina Illuminazione SpA  
Casella Postale 604  
36100 Vicenza

### New Zealand

Thorn Electrical Industries (NZ) Limited  
PO Box 15150  
New Lynn  
Auckland 7

### Norway

Norske Thorn A/S  
Postbox 7065  
Oslo 3

### South Africa

Thorn Lighting (SA) Limited  
PO Box 43075  
Industria  
Transvaal

### Sweden

Svenska Thorn AB  
Box 20075  
S-16120 Bromma

Publication Number TL00122/11/72

Designed by Alan Crow Associates  
Page 3 photograph by Adrian Hobbs



