



Over dit boek

Dit is een digitale kopie van een boek dat al generaties lang op bibliotheekplanken heeft gestaan, maar nu zorgvuldig is gescand door Google. Dat doen we omdat we alle boeken ter wereld online beschikbaar willen maken.

Dit boek is zo oud dat het auteursrecht erop is verlopen, zodat het boek nu deel uitmaakt van het publieke domein. Een boek dat tot het publieke domein behoort, is een boek dat nooit onder het auteursrecht is gevallen, of waarvan de wettelijke auteursrechttermijn is verlopen. Het kan per land verschillen of een boek tot het publieke domein behoort. Boeken in het publieke domein zijn een stem uit het verleden. Ze vormen een bron van geschiedenis, cultuur en kennis die anders moeilijk te verkrijgen zou zijn.

Aantekeningen, opmerkingen en andere kanttekeningen die in het origineel stonden, worden weergegeven in dit bestand, als herinnering aan de lange reis die het boek heeft gemaakt van uitgever naar bibliotheek, en uiteindelijk naar u.

Richtlijnen voor gebruik

Google werkt samen met bibliotheken om materiaal uit het publieke domein te digitaliseren, zodat het voor iedereen beschikbaar wordt. Boeken uit het publieke domein behoren toe aan het publiek; wij bewaren ze alleen. Dit is echter een kostbaar proces. Om deze dienst te kunnen blijven leveren, hebben we maatregelen genomen om misbruik door commerciële partijen te voorkomen, zoals het plaatsen van technische beperkingen op automatisch zoeken.

Verder vragen we u het volgende:

- + *Gebruik de bestanden alleen voor niet-commerciële doeleinden* We hebben Zoeken naar boeken met Google ontworpen voor gebruik door individuen. We vragen u deze bestanden alleen te gebruiken voor persoonlijke en niet-commerciële doeleinden.
- + *Voer geen geautomatiseerde zoekopdrachten uit* Stuur geen geautomatiseerde zoekopdrachten naar het systeem van Google. Als u onderzoek doet naar computervertalingen, optische tekenherkenning of andere wetenschapsgebieden waarbij u toegang nodig heeft tot grote hoeveelheden tekst, kunt u contact met ons opnemen. We raden u aan hiervoor materiaal uit het publieke domein te gebruiken, en kunnen u misschien hiermee van dienst zijn.
- + *Laat de eigendomsverklaring staan* Het “watermerk” van Google dat u onder aan elk bestand ziet, dient om mensen informatie over het project te geven, en ze te helpen extra materiaal te vinden met Zoeken naar boeken met Google. Verwijder dit watermerk niet.
- + *Houd u aan de wet* Wat u ook doet, houd er rekening mee dat u er zelf verantwoordelijk voor bent dat alles wat u doet legaal is. U kunt er niet van uitgaan dat wanneer een werk beschikbaar lijkt te zijn voor het publieke domein in de Verenigde Staten, het ook publiek domein is voor gebruikers in andere landen. Of er nog auteursrecht op een boek rust, verschilt per land. We kunnen u niet vertellen wat u in uw geval met een bepaald boek mag doen. Neem niet zomaar aan dat u een boek overal ter wereld op allerlei manieren kunt gebruiken, wanneer het eenmaal in Zoeken naar boeken met Google staat. De wettelijke aansprakelijkheid voor auteursrechten is behoorlijk streng.

Informatie over Zoeken naar boeken met Google

Het doel van Google is om alle informatie wereldwijd toegankelijk en bruikbaar te maken. Zoeken naar boeken met Google helpt lezers boeken uit allerlei landen te ontdekken, en helpt auteurs en uitgevers om een nieuw leespubliek te bereiken. U kunt de volledige tekst van dit boek doorzoeken op het web via <http://books.google.com>

This is a reproduction of a library book that was digitized by Google as part of an ongoing effort to preserve the information in books and make it universally accessible.

Google™ books

<http://books.google.com>

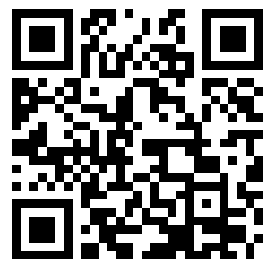

36m
480
NBS Special
Publication
480-17
1978

Auto Headlight Glass: Visible Features of Forensic Utility

DEPOSITORY
MAR 30 1978
UNIV. OF ILL. LIBRARY
AT URBANA-CHAMPAIGN



Law Enforcement
Equipment
Technology

U.S. DEPARTMENT OF
COMMERCE
National Bureau of
Standards



**NBS Special
Publication
480-17**

Auto Headlight Glass: Visible Features of Forensic Utility

prepared by
Harold L. Steinberg
Center for Consumer Product Technology
National Bureau of Standards
Washington, D.C. 20234

and the

Law Enforcement Standards Laboratory
Center for Consumer Product Technology
National Bureau of Standards
Washington, D.C. 20234

prepared for
**National Institute of Law
Enforcement and Criminal Justice**
Law Enforcement Assistance Administration
U.S. Department of Justice
Washington, D. C. 20531

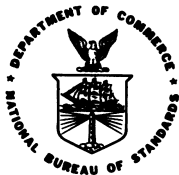

**Issued
February 1978**

U.S. DEPARTMENT OF COMMERCE, Juanita M. Kreps, *Secretary*
Dr. Sidney Harman, *Under Secretary*
Jordan J. Baruch, *Assistant Secretary for Science and Technology*
NATIONAL BUREAU OF STANDARDS, Ernest Ambler, *Acting Director*

Disclaimer:

Certain trade names and company products are identified in order to adequately specify the experimental procedure. In no case does such identification imply recommendation or endorsement by the National Bureau of Standards, nor does it imply that the products are necessarily the best available for the purpose.

Library of Congress Catalog Number: 78-600010
National Bureau of Standards
Special Publication 480-17
Nat. Bur. Stand. (U.S.), Spec. Publ. 480-17, 137 pages
CODEN: XNBSAV

U.S. GOVERNMENT PRINTING OFFICE
WASHINGTON: 1978

For sale by the Superintendent of Documents,
U.S. Government Printing Office, Washington, D.C. 20402
Stock No. 003-003-01857-1 Price \$3
(Add 25 percent additional for other than U.S. mailing)

Contents

	Page
Foreword -----	v
1. Introduction -----	1
2. General Overview -----	1
3. Visible Features of Headlights -----	12
3.1. Fluting Patterns -----	12
3.2. Logos -----	21
3.3. Mold, Plunger and Other Lens Markings -----	26
3.4. Beam-Type Markings -----	31
3.5. Curvature -----	31
3.6. Headlight Aiming Pads -----	31
3.7. Reflector Markings -----	32
3.8. Color -----	33
Appendix A—Photographs of Headlight Lenses -----	33
Appendix B—Selected Illustrations of Westinghouse Headlight Lenses -----	110
Appendix C—Selected Illustrations of General Electric Headlight Lenses -----	123

List of Tables

Tables	Page
1. Some visible features that can have forensic utility -----	1
2. Sealed beam headlight glass- and lampmakers -----	3
3. Sealed beam headlight OEM suppliers for each major automaker -----	4
4. Estimated percentages of OEM and replacement headlights for passenger vehicles -----	5
5. Basic lamp data -----	6
6. Sealed beam headlights used as OEM in U.S. passenger vehicles by make, model and model year -----	7
7. Sealed beam headlights used as OEM in imported passenger vehicles, by make, model and model year -----	9
8. Domestic shipments of sealed beam headlights and motor vehicle factory sales/imports -----	11
9a. Interpretive data for code and plunger numbers on Corning 8100 Series, Par 46 (high beam) lenses -----	13
9b. Interpretive data for code and plunger numbers on Corning 8200 Series, Par 46 (low beam) lenses -----	15
9c. Interpretive data for code and plunger numbers on Corning 8100 Series, Par 56 (6V, twin beam) lenses -----	17
9d. Interpretive data for code and plunger numbers on Corning 8200 Series, Par 56 (6, 12V twin beam) lenses -----	18
10. Lens mold data for Corning lenses -----	22
A1. Data for lenses shown in appendix A -----	34

List of Figures

	Page
Figures	
1. (a) Pre-1961 Guide Headlamps; (b) 1963-1970 Guide Headlamps; and (c) Recent Guide Lamps -----	24
2a. Genealogy of Westinghouse Par 46 Sealed Beam Headlights -----	25
2b. Genealogy of Westinghouse Par 56 Sealed Beam Headlights -----	26
3a. Westinghouse Logo Details -----	27
3b. Additional Westinghouse Logo Details -----	28
4. Dimensions of "1" and "2" on Westinghouse Lamps -----	29
5. Time Distributions for the Alphabetic Prefixes to Corning's Par 46 and Par 56 Lens Mold Numbers -----	30
A1-74. Illustrations of the Various Sealed Beam Headlamp Fluting Patterns -----	36-109
B1-22. Selected Illustrations of Westinghouse Headlight Lenses -----	110-122
C1-16. Selected Illustrations of General Electric Headlight Lenses -----	123-131

FOREWORD

The Law Enforcement Standards Laboratory (LESL) of the National Bureau of Standards (NBS) furnishes technical support to the National Institute of Law Enforcement and Criminal Justice (NILECJ) program to strengthen law enforcement and criminal justice in the United States. LESL's function is to conduct research that will assist law enforcement and criminal justice agencies in the selection and procurement of quality equipment.

LESL is: (1) Subjecting existing equipment to laboratory testing and evaluation and (2) conducting research leading to the development of several series of documents, including national voluntary equipment standards, user guidelines, state-of-the-art surveys and other reports.

This document is a law enforcement equipment report developed by LESL under the sponsorship of NILECJ. Additional reports as well as other documents are being issued under the LESL program in the areas of protective equipment, communications equipment, security systems, weapons, emergency equipment, investigative aids, vehicles and clothing.

Technical comments and suggestions concerning the subject matter of this report are invited from all interested parties. Comments should be addressed to the Law Enforcement Standards Laboratory, National Bureau of Standards, Washington, D.C. 20234.

Jacob J. Diamond
Chief, Law Enforcement
Standards Laboratory

AUTO HEADLIGHT GLASS: VISIBLE FEATURES OF FORENSIC UTILITY

This report documents those visible features of sealed beam auto headlights which may be of use in criminal investigations. These visible features include fluting pattern, lampmaker monogram, mold markings, and curvature. Only sealed beam headlights used on passenger vehicles having significant U.S. sales are considered. The data presented are current through 1974.

Key words: Auto accident investigation, fluting pattern; forensic science; headlight glass; hit-and-run accidents; sealed beam headlights

1. INTRODUCTION

The aim of this document is to aid the work of the forensic scientist in extracting information from headlight glass fragments for purposes of vehicle identification. Its scope is limited to descriptions of the markings and other visible features of lenses and reflectors from sealed beam headlights used in passenger vehicles having significant U.S. sales. These markings and other visible features are listed in table 1.

TABLE 1. *Some visible features that can have forensic utility*

- (a) Fluting pattern
- (b) Lampmaker or automaker logo
- (c) Mold, plunger, and other lens markings
- (d) Beam-type ("1" or "2") marking
- (e) Curvature
- (f) Type of aiming pad
- (g) Reflector markings
- (h) Color

This document is the second of a three part series. The first concerns the characterization of auto headlight glass by its refractive index and density. The third concerns the characterization of auto headlight glass by its trace element content.

Section 2 contains general information regarding the companies that manufacture sealed beam headlights, the processes by which the lamps are fabricated, and other general data regarding headlights.

Section 3 describes the various markings and other visible features of passenger vehicle sealed beam headlights which can assist the criminalist in inferring the age, beam-type and make of a sealed beam headlight. This information, when taken in conjunction with the production data presented in section 2, can facilitate deductions regarding the make and model of the vehicle in question.

Appendix A contains illustrations of the lens patterns. Production data regarding each lens pattern can be found in table A1.

Appendix B gives lens drawings, schematics of selected Westinghouse monograms, and some specifications for early Westinghouse monograms.

Appendix C gives selected depictions of General Electric's Par 46 and 56 headlamp lenses.

2. GENERAL OVERVIEW

All headlights on motor vehicles intended for use on U.S. highways must be the sealed beam type.

The companies that mold lenses and reflectors—referred to as “glassmakers”—and those that assemble the component parts into the completed headlights—referred to as “lampmakers”—are listed in table 2. Lampmakers of original equipment (hereafter referred to as OEM) headlights for the major makes of passenger vehicles presently sold in the U.S. are shown in table 3. Note that some imported vehicles have American-made headlights installed upon entry into this country (e.g., Volvo). Estimates of the overall percentages of OEM and replacement lamps for each major lampmaker or distributor are listed in table 4. These data may lend support to deductions as to the OEM or replacement nature of headlights of identified make.

Passenger vehicles intended for use in the United States must use one of the following systems to be in compliance with Society of Automotive Engineers (SAE) and U.S. Dept. of Transportation (DOT) standards regarding sealed beam headlights:

(1) Two Circular Headlights—two 7" diameter twin beams, called “Par 56” headlights by the industry.

(2) Two Rectangular Headlights—two 5×7.5 " twin beams, classified as “Par 56,” Type 2" lamps. Available for the first time in some 1977 passenger vehicles.

(3) Four Circular Headlights—two 5.75" diameter double-filamented low beams, and two 5.75" diameter single-filamented high beams. These lights are in the “Par 46” class of headlamp, and are referred to as “Type 2” and “Type 1,” respectively.

(4) Four Rectangular Headlights—two 4×6.5 " rectangular, double-filamented low beams, and two 4×6.5 " rectangular high beams. These lights, referred to as Type 2A and 1A, respectively, made their first U.S. appearance on 1975 model year Monza, Skyhawk, Starfire and most full-sized GM passenger vehicles. These lamps are also considered by the industry to be “Par 46” lamps.

Sealed beam headlights are typed according to their lamp size, beam type, design voltage, wattage rating, and duty type. Lamp-type number assignment is generally independent of the lampmaker, but exceptions exist. Each unique sealed beam headlight type commonly found on domestically registered vehicles is listed, along with its attributes, in table 5. Lamps of the same beam type and voltage rating, but of different lamp types (see column 2, table 5), are interchangeable and may have the same lens patterns. Thus 6012, 6013, 6014, 6015, and 6016 lamps can be interchanged, while a 4002 lamp can be replaced by a 4000 or 4005 lamp.

The types of OEM lamps used in domestically manufactured passenger cars for the model years 1962 through 1974 are listed in table 6. The numbers in table 6 refer to the listings in table 5. Table 7 is in the same format as table 6, and lists the headlight types used for imported passenger vehicles. Total sealed beam headlight production, and U.S. factory sales of motor vehicles for the calendar years 1967 through 1974 are listed in table 8.

The industrial process by which headlamps are manufactured consists of the following steps:

(1) The glass is formed in a large glass tank into which the raw materials are placed, along with 20 percent or more of scrap glass (“cullet”). Headlight glass is a borosilicate glass. Without benefit of mechanical stirring, the glass is formed and slowly passes through the tank by gravity feed.

(2) At the exit port of each tank, glass is placed into lenses and reflector “molds.” These components are then pressed out by means of “plungers.” The mold forms the smooth outer surface of a lens or reflector. The plunger creates the fluting pattern and other markings on the inner surface of the lens.

(3) Lenses and reflectors are shipped from glassmaker to lampmaker. The time between lens formation and reception by the lampmaker is on the order of one or two weeks. The lampmaker aluminizes each reflector, inserts the filaments, ferrules, etc., and then seals the reflector

TABLE 2. Sealed beam headlight glass- and lampmakers

Lampmakers ^a	Associated Glassmakers ^b
Guide Lamp: Anderson, Indiana Westinghouse: Fairmont, West Virginia Wagner Electric (Tung-Sol): Boyertown, Pennsylvania ^c General Electric (Trumbull Lamp Plant): Warren, Ohio ^d General Electric (Lexington Lamp Plant): Lexington, Ky. ^d Canadian General Electric (CGE): Oakville (Toronto), Canada Koito/Stanley: Japan ^d Toshiba: Japan ^d Lucas (British Sealed Beams, LTD): Rockingham Road, Corby, Great Britain Other: ^e	Corning Glass Co., Greenville, Ohio Corning Glass Co., Greenville, Ohio Corning Glass Co., Greenville, Ohio General Electric: Mahoning Glass Plant, Niles, Ohio General Electric: Somerset Glass Plant, Somerset, Ky. General Electric: Mahoning Glass Plant, Niles, Ohio Iwaki Glass Co., Tokyo, Japan Showa Glass Co., Japan Glass Bulbs, G.B.

^a A few companies (e.g., Sears, Atlas, Eveready) market lamps purchased from one of the above-mentioned lampmakers.

^b The associations made here represent the general situation in 1974. Exceptions to each of these associations occurred occasionally. Anchor Hocking Co. made glass components for Guide and Westinghouse lamps until early 1972, when they went out of the business.

^c Wagner Electric has a lampmaking plant in Canada. It receives its glass components from Corning.

^d General Electric makes some lamps or lamp components for "Stanley."

^e Other foreign lampmakers and glassmakers exist but their impact on the U.S. passenger vehicle, sealed beam headlamp market is small.

to an appropriate lens, forming a headlight. This lamp is then gas filled and sealed. Each lens is stressed during annealing to strengthen the glass against breakage. The time spent by lenses and reflectors at the lampmakers ranges from 2 to 6 weeks. The headlight may then be shipped either directly to the automaker, or to an intermediate company that inserts headlamps into appropriate housings and then ships the integrated units to the automaker. All U.S. automakers use the first (direct) approach, but AMC and Chrysler have, upon occasion, also used the latter (2-step) procedure. The 2-step process will, typically, add an additional 10 days to the overall time between lamp production and auto assembly. However, just before the new model-year production begins, the lamps may be stored at the integrated unit assembler's plant for up to 2 months.

TABLE 3. Sealed beam headlight OEM suppliers for each major automaker

Quantitative array elements, if available, are given as percentages.

Auto Maker	TS	West	Guide	GE	Lucas	Koito	Toshiba	Hella	Other (h)
AMC	100 (a)	— (b)	—	—	—	—	—	—	—
Ford	~35	~15	—	~50 (d)	—	—	—	—	—
Chrysler	~25 (c)	~25	—	~50	—	—	—	—	—
GM	—	—	100 (g)	—	—	—	—	—	—
Alpha Romeo	(e)								
Anglia									
Audi				✓ (c)					
Austin									
BMW				✓				?	
Cortina									
Datsun				✓		✓	✓		
Fiat		~100							
Honda		✓							
Jaguar					✓ (f)				
Jeep									
Mazda									
Mercedes				✓					
MG					✓ (f)				
Morris									
Opel			~100 (g)						
Peugeot	✓								
Porsche				✓					
Renault	✓								
Saab				✓					
Simca				✓					
Subaru									
Sunbeam									

TABLE 3. Sealed beam headlight OEM suppliers for each major automaker—Continued

Auto Maker	TS	West	Guide	GE	Lucas	Koito	Toshiba	Hella	Other (h)
Toyota						✓	✓		
Triumph					✓				
Vauxhall									
VW		~50		~50 (d)					
Volvo	≅50			≤50					
Capri				✓					

^a All AMC passenger vehicles have used Tung-Sol (TS) headlamps as original equipment since about 1967.

^b The Dash (—) symbol means negligible usage as original equipment.

^c The checkmark (✓) symbol means a significant, but unquantified, usage as original equipment. These checkmarks generally relate to observations made in the Washington, D.C., Metropolitan Area. However, since many foreign-made motor vehicles do not have their headlamps installed until they arrive in the U.S., the potential for regional dependence in headlamp usage exists.

^d Significant use is made of Canadian GE (CGE) headlamps in VW's and in Canadian-assembled Ford and Chrysler cars destined for the U.S. market. Ford is now purchasing more 7" lamps than 5.75" lamps from GE. A few years back the situation was just the opposite.

^e Blanks in the table denote unknown usage factors.

^f Leland (British) vehicles taking 7" twin-beam lamps generally have Lucas lamps as original equipment. Since these lamps are quite expensive, they are frequently replaced with U.S. made equivalents. Imported Leland vehicles taking 5.75" lamps use U.S.-made lamps as original equipment.

^g GM cars have used 100 percent Guide lamps for at least the last ten years.

^h Stanley headlamps may appear in some Japanese-made vehicles. GE makes some of these lamps and, presumably, Iwaki (see table 2) makes the remainder.

TABLE 4. Estimated percentages of OEM and replacement headlights for passenger vehicles

Lampmaker/distributor	Percentages	
	OEM trade	Replacement trade
General Electric (GE)	20%	40%
Guide	50	15-18
Tung-Sol (TS)	20	20
Westinghouse	10	20
Atlas	~0	4-5
Lucas	Small	~0
Toshiba	?	~0
Koito	?	~0
Stanley	Small	~0

TABLE 5. Basic lamp data

No.	Lamp Type	Diameter Inches	Design Volts ^a	Beam Type/ No. Filaments	Design Watts	Duty ^b	Production Dates/Status as of October 1974												Comments
							G.E.		T-S		West.		Guide		Atlas ^c		Koito/ Stanley		
							In	Out	In	Out	In	Out	In	Out	In	Out	In	Out	
1	4000	5.75	12.8	Low/2	37.5/60	R	12-29-69	4-7-71	7-1-70	7-1-70	70	70	72	4-15-71	4-72/10-74	Brighter than 4002			
2	4001/A	5.75	12.8	High/1	37.5	R	'56	(^m)	1-1-56	1-1-56	56	56	1-1-56	11-62	10-73/10-74	Replaced by 4000			
3	4002	5.75	12.8	Low/2	37.5/50	R	'56	1-74	1-1-56	1-1-74	56	56	1-1-56	7-1-70	10-73/10-74				
4	4005	5.75	12.8	Low/2	37.5/50	H	(^m)	7-74	7-1-70	7-1-70	39	39	7-1-70			Brighter than 4002			
5	4006	5.75	12.8	High/1	37.5	H	7-1-70									Brighter than 4001			
6	4030	7	6.2	Twin/2	62	R	✓	✓(ⁿ)	7-1-70	7-1-70	70	70	7-1-70			Brighter than 4001			
7	4040	7	12.8	Low/2	37.5/60	H	✓	4-7-71	7-1-70	7-1-70	72	72	7-1-70			Brighter than 4001			
8	4101	5.75	12.8	High/1	50	R		'58	7-1-70	7-1-70	55	55				Equivalent to 6006			
9	5001	5.75	12.8	High/1	50	R	'53	'58	7-1-70	7-1-70	55	55				Equivalent to 6014			
10	5040/S ^d	7	6.2	Twin/2	50/40	R	'53	'58	7-1-70	7-1-70	59	59				Replaced by 6013 or 6015			
11	5400/S ^d	7	12.8	Twin/2	50/40	H	'53	'58	7-1-70	7-1-70	59	59							
12	5440	7	12.8	Twin/2	50/40	R	'53	'58	7-1-70	7-1-70	59	59							
13	6006	7	6.4	Twin/2	50/40	R	'58	✓(^l)	6-1-57	6-1-57	58	58	6-1-57		10-73/10-74	Replaced by 6014			
14	6012/S	7	12.8	Twin/2	50/40	R	'58	✓(^l)	6-1-57	6-1-57	58	58	6-1-57		10-73/10-74	Replaced by 6014			
15	6013 ^b	7	12.8	Twin/2	50/40	H	'59		6-1-57	6-1-57	69	69	6-1-57			6013~6015~6016			
16	6014/S	7	12.8	Twin/2	60/50	R	11-21-69	8-11-71	6-1-57	6-1-57	69	69	1970			Brighter than 6012			
17	6015 ^b	7	12.8	Twin/2	60/50	H	'69		6-1-57	6-1-57	69	69							
18	6016	7	12.8	Twin/2	60/50	H			6-1-57	6-1-57	69	69							
19	6112	7	12.8	Twin/2	50/40	R	Export Only		6-1-57	6-1-57	69	69							
20	1A	4 × 6½	12.8	High/1	50	R			6-1-57	6-1-57	69	69				Rectangular lamps			
21	2A	4 × 6½	12.8	Low/2	60/	R			6-1-57	6-1-57	69	69				Rectangular lamps			
22	2B	4 × 6½	12.8	Twin/2	60/	R			6-1-57	6-1-57	69	69				Rectangular lamps			

^a Voltage and duty-type lamp characteristics generally relate to lamp filament and filament supports. Heavy duty lamps are generally used as OEM in trucks.

^b Tung-Sol equivalents of the 6013 and 6015 lamps are the 6012-S and the 6014-S, respectively.

^c The 6016 Guide lamp is roughly equivalent to GE's 6015 and Tung-Sol's 6014-S lamps.

^d GE replaced 5040 and 5400 lamps with 5040S- and 5400S-type lamps in 1956. The "S" suffix denotes a modification in aiming platforms.

^e Replaced by 6016 lamp.

^f Replaced by 4040 lamp.

^g Replaced by 5001 lamp.

^h These numbers are used in tables 6 and 7.

ⁱ Except for some Ford trucks which still use these type lamps.

^j The date to the left of the slash represents the date that Iwaki began producing the lenses for Koito. The date to the right is the Stanley counterpart.

^k Atlas/GE, Par 46 lamps are assembled at GE's Mahoning Plant, Atlas/GE, Par 56 lamps are assembled in Somerset, Ky. Exceptions may occur.

^l Recent headlamp production by GE, Wagner Electric (T-S), and Westinghouse for Atlas Supply Co., has been in the approximate ratios of 1:2:4. "Out" dates for GE/Atlas and West./Atlas were not obtained.

^m Blanks in both "In" and "Out" boxes generally means this lamp is not made by that company. A blank on the "In" box only means the production start date is not known.

A blank in the "Out" box only means either that the lamp is still in production (3/75) or the ending date was not obtained.

ⁿ A check mark (✓), depending on whether it appears in an "In" or "Out" box means that the lamp was put into or taken out of service, respectively, but at an undetermined date.

TABLE 6. Sealed beam headlights used as OEM^a in U.S. passenger vehicles by make, model and model year

Make/Model	Model Year												
	'74	'73	'72	'71	'70	'69	'68	'67	'66	'65	'64	'63	'62
American Motors AMC	Ambassador	1,9 ^(b)	1,9	1,9	1,2/2,3 ^(d)	2,3	— ^(c)	14	14	14	14	—	—
	American					16	14	14	14	14	14	—	—
	AMX (30)			16	14/16	14/16	14	—	—	—	—	—	—
	Hornet/Gremlin	16	16	16	16	16	14	—	—	—	—	—	—
	Javelin/AMX (70)	16	16	16	1,2/2,3	—	—	—	—	—	—	—	—
	Matador	1,9	1,9	1,9	—	(1,3) ^{e,9}	2,3	2,3	2,3	2,3	2,3	2,3	2,3
	Rambler												
	Rebel												
General Motors Buick	Apollo	16											
	Buick (Other)	1,9	1,9	1,9/2,3	2,3	2,3	2,3	2,3	2,3	2,3	2,3	2,3	2,3
	Special	16	1,9	1,9/2,3	2,3	2,3	2,3	2,3	2,3	2,3	2,3	2,3	2,3
	Opel	16/1,10	16/1,9	14/2,3	14	14	13	14	14	14	14	—	—
	Riviera	1,9	1,9	1,9/2,3	2,3	2,3	2,3	2,3	2,3	2,3	2,3	2,3	2,3
	Century/Luxus/Regal	16											
Chevy	Cadillac	1,9	1,9	2,3	2,3	2,3	2,3	2,3	2,3	2,3	2,3	2,3	2,3
	Canaro	16	16	16	16	14/16	14	14	14	14	—	—	—
	Chevelle	16	16	16	16	2,3	2,3	2,3	2,3	2,3	2,3	2,3	2,3
	Chevrolet (other)	1,9	1,9	2,3	2,3	2,3	2,3	2,3	2,3	2,3	2,3	2,3	2,3
	Chevy II/Nova	16	16	16	16	14	14	14	14	14	14	14	14
	Corvair												
	Corvette	1,9	1,9	2,3	2,3	2,3	2,3	2,3	2,3	2,3	2,3	2,3	2,3
	Impala	—	1,9	1,9	—	—	—	—	—	—	—	—	—
	Monte Carlo	16	16	16	16	14	14	14	14	14	14	14	14
	Vega	16	16	16	16	—	—	—	—	—	—	—	—
Oldsmobile	Cutlass/F85	16	1,9	1,9/2,3	2,3	2,3	2,3	2,3	2,3	2,3	2,3	2,3	2,3
	Oldsmobile (Other)	1,9	1,9	1,9/2,3	2,3	2,3	2,3	2,3	2,3	2,3	2,3	2,3	2,3
	Omega	16	16	—	—	—	—	—	—	—	—	—	—
Pontiac	Firebird	16	14/16	1,2/2,3	2,3	2,3	2,3	—	—	—	—	—	—
	Grand Am	16	14/16	—	—	—	—	—	—	—	—	—	—
	Grand Prix	16	14/16	14	2,3	2,3	—	—	—	—	—	—	—
	Le Mans/Ventura	16	14/16	—	—	—	—	—	—	—	—	—	—
	Pontiac (Other)	1,9	1,9	1,9	2,3	2,3	2,3	2,3	2,3	2,3	2,3	2,3	2,3
	Tempest	1,9	—	2,3	2,3	2,3	2,3	2,3	2,3	2,3	2,3	2,3	2,3
Ford Motor Co. Ford	Fairlane/Torino	1,2	1,2	1,2/2,3	2,3	2,3	2,3	2,3	2,3	2,3	2,3	2,3	2,3
	Falcon/Futura												
	Ford (Other)	1,2	1,2	1,2/2,3	2,3	2,3	2,3	2,3	2,3	2,3	2,3	2,3	2,3

TABLE 6. Sealed beam headlights used as OEM^a in U.S. passenger vehicles by make, model and model year—Continued

Make/Model	Model, Year												
	'74	'73	'72	'71	'70	'69	'68	'67	'66	'65	'64	'63	'62
Maverick	16	16	14/16	14	—	14	14	14	14	14	—		
Mustang II, Ghia	16	16	14,9	14/16	14	14	14	14	14	14	—		
Pinto	16	—	14/16	—	2,3	2,3	2,3	2,3	2,3	2,3	2,3	2,3
Thunderbird	1,2	1,2	1,2/2,3	2,3	2,3	2,3	2,3	2,3	2,3	2,3	2,3	2,3	2,3
Continental	1,2	1,2	1,2/2,3	2,3	2,3	2,3	2,3	2,3	2,3	2,3	2,3	2,3	2,3
Mark IV	1,2	1,2	1,2/2,3	—	2,3	2,3	—	—	—	—	—	—	—
Mark III	1,2	1,2	1,2/2,3	2,3	2,3	2,3	2,3	2,3	2,3	2,3	2,3	2,3	2,3
Comet	16	16	14/16	14/2,3	2,3	2,3	2,3	2,3	2,3	2,3	2,3	2,3	..
Cougar	1,2	1,2	2,3	2,3	2,3	2,3	2,3	2,3	—	2,3	2,3	2,3	2,3
Mercury (Other)	1,2	1,2	2,3	2,3	2,3	2,3	2,3	2,3	2,3	2,3	2,3	2,3	2,3
Meteor	—	2,3	2,3	2,3	2,3	2,3	2,3	2,3	2,3
Montego/Cyclone	1,2	1,2	1,2/2,3	2,3	2,3	2,3	2,3	—	—	—	—	—	—
All Chrysler	1,2	1,2	1,2	1,2/2,3	2,3	2,3	2,3	2,3	2,3	2,3	2,3	2,3	2,3
Challenger	1,2	1,2	1,2	1,2/2,3	2,3	—	2,3	2,3	2,3	(2,3)	—
Charger/Coronet	1,2	1,2	1,2	1,2/2,3	1,2/2,3	2,3	2,3	2,3	2,3	2,3	2,3	2,3	2,3
Colt	1,2	1,2	1,2	1,2	—	—	—	—	—	—	—	—	—
Dart	16	16	14	14	14	14	14	14	14	14	14	14	14
Demon	—	(14)	14	14	—	—	—	—	—	—	—	—	—
Dodge (Other)	1,2	1,2	1,2	1,2	2,3	2,3	2,3	2,3	2,3	2,3	2,3	2,3	2,3
Lancer	1,2	1,2	1,2	1,2	2,3	2,3	2,3	2,3	2,3	2,3	2,3	2,3	2,3
Swinger	16	16	14	14	14	14	14	—	—	—	—	—	—
Belvedere	—	—	1,2/2,3	2,3	2,3	2,3	2,3	2,3	—	—	—
Cricket	—	—	1,2	1,2/2,3	—	—	—	—	—	—	—	—
Fury	1,2	1,2	1,2	1,2/2,3	2,3	2,3	2,3	2,3	2,3	—	—	—
Duster	1,6	16	14	14	14	14	14	—	—	—	—	—
Plymouth	1,2	1,2	1,2	1,2/2,3	2,3	2,3	2,3	2,3	2,3	2,3	2,3	2,3	2,3
Scamp	16	16	14	14	—	—	—	—	—	14	14	14	14
Valiant/Barracuda	16	16	14	14	14	14	14	14	14	14	14	14	14
Jeep	16	16	14	14	14	14	14	14	14	14	14	14	14
Checker	1,9/2,3	1,9/2,3	2,3	2,3	2,3	2,3	2,3	2,3	2,3	2,3	2,3	2,3	2,3
Studebaker	1,9/2,3	1,9/2,3	2,3	2,3	2,3	2,3	2,3	2,3	2,3	2,3	2,3	2,3	2,3
Lark	—	—	—	—	—	—	—	—	—	—	—	—	—
Studebaker (Other)	—	—	—	—	—	—	—	—	—	—	—	—	—

^a "OEM" means original equipment manufactured.

^b X, Y notation indicates the particular model (and year) took a quad (High + Low) beam configuration.

^c A dash indicates the year in which production of a model car ceased, or year before it began.

^d A slash separating two groups of numbers indicates either or both types of headlamps were installed in the respective model car during the specified year.

^e A dotted line indicates an unknown or indefinite quality.

^f Numbers in parentheses represent inferred quantities.

TABLE 7. Sealed beam headlights used as OEM in imported passenger vehicles, by make, model and model year

Make/Model	74	73	72	71	70	69	68	67	66	65	64	63	62
Audi 100 SL	1,2	1,2	1,2	1,2									
All Others	14	14	14	14									
Austin-American	—	14	14	14	14	14	14	14	14	14	14	14	14
Austin-Healey	16	16	16/14	14	14	14	14	14	14	14	14	14	14
BMW 1300 & 1800 2000							13/14	13	13	13			
Citroen			1,2/2,3										
Datsun 1200 & 240Z		14	14	14	14								
All Others	2,3	2,3	2,3	2,3	2,3								
Fiat 850	14	14	14	14	14	14	14	14	14	14	14	14	14
All Others	2,3	2,3	2,3	2,3	14	14	14	14	14	14	14	14	14
Ford (English)													
Cortina	16	16	16/14	14	14	14	14	14	14	14	14	14	14
All Others												
Ford (German)													
Capri	1,2	1,2											13
All Others	16	16	2,3	2,3	2,3	2,3	2,3	2,3	2,3	2,3	2,3	2,3	13
Hillman (All Models)													
Jaguar (All Models)		2,3	2,3/14	2,3	14	14	14	14	14	14	14	14	14
Mazda	1,2												
Mercedes-Benz													
190, 300, 300 SL, 220,													
230 SL, 200, 200 D, 230,													
2200													
All Others	2,3	2,3	2,3	14	14	14	14	14	14	14	14	14	14
				2,3	2,3	2,3	2,3	2,3	2,3	2,3	2,3	2,3	2,3

The numbers below refer to the beam types listed in table 5, column 1.

TABLE 7. Sealed beam headlights used as OEM in imported passenger vehicles, by make, model and model year—Continued

Make/Model	74	73	72	71	70	69	68	67	66	65	64	63	62
The numbers below refer to the beam types listed in table 5, column 1.													
MG (All Models)		14	14	14	14	14	14	14	14	14	14	14	14
Morris				14	14	14	14	14	14	14	14	14	14
Peugeot (All Models)	2,3	14/2,3	14/2,3	14	14	14	14	14	14	14	14	14	14
Porsche	14	14	14	14	14	14	14	14	14	14	13/14	13/14	13
Renault-16		14	14	2,3	2,3	2,3	14	14	14	14	14	14	14
All Others		14	14	14	14	14	14	14	14	14	14	14	14
Rover			2,3	2,3	2,3	2,3	2,3	14	14	14	14	14
Land Rover			14	14	14	14	14	14	14	14	14	14
Saab	1,2	16/14	16/14	14	14	14	14	14	14	14	14	14	14
Simca			(16/14)	14	14	14	14	14	14	14	14	14
Subaru	14	14	—										
Sunbeam Alpine			2,3	2,3	2,3	14	14	14	14	14	(14)	14	14
All Others			14	14	14	14	14	14	14	14	14	14	14
Toyota—Corolla	14	14	14	14	14	14	14	14	14	14	14	14	14/2,3
Land Cruiser, Pick-Up	2,3	2,3	2,3	2,3	2,3	14	14	14	14	14	14	(14)	14
All Others	14	14	14	14	14	14	14	14	14	14	14	14	14
Triumph	14	14	14	14	14	14	14	14	14	14	14	14	14
Vauxhall													
Volkswagen	16	16	14	14	14	14	14	14	14	14	14	14	14
Volvo	14	14	14	14	14	14	14	14	14	14	14	14	14

For explanation of quantities/notation of this table, refer to footnotes of table 6.

TABLE 8. Domestic shipments of sealed beam headlights and motor vehicle factory sales/imports

Year	Domestic Sealed Beam Lamp Shipments ^a		Ratio New 4-Lamp Cars to 2-Lamp Cars	Ratio Par 46 to Par 56 OEM Lamps	Ratio New 4-Lamp Cars to 2-Lamp Cars	U.S. Factory Sales ^e		New Passenger ^f Vehicle Imports	
	Replacement ^c					Passenger Vehicles	Trucks and Buses	Canada	Other
	Par 46 ^d	Par 56 ^e							
1974	16.9 × 10 ⁶	10.4 × 10 ⁶	16.3 × 10 ⁶	1.6	0.8	7.2 × 10 ⁶	2.70 × 10 ⁶	0.70 × 10 ⁶	1.41 × 10 ⁶
1974 [†]	1.4	-----	~0.4	-----	-----	-----	-----	-----	-----
1973	24.4	13.8	16.0	1.8	0.9	9.67		0.87	1.56
1972	22	13	18.6	1.7	0.8	8.83		0.84	1.64
1971	24	11	17	2.2	1.1	8.58	2.05	0.80	1.79
1970	20	8.0	15	2.5	1.2	6.55	1.69	0.69	1.32
1969	28	7.1	17	3.9	2.0	8.22	1.92	0.69	1.16
1968	31	6.1	24	5.1	2.6	8.82	1.90		1.03
1967	24	5.3	18	4.5	2.2	7.44	1.54		0.77

^a "Domestic Sealed Beam Lamp Shipments" data are, essentially, Census Bureau data (see their "Current Industrial Reports," Series MQ-36B) that have been modified to remove non-headlamp components. All 1974 data were estimated by GE.

^b OEM (Original Equipment). The data in columns 2 and 3 are based on Census data labeled "Bulk Packed."

^c "Replacement" data for 1967 through 1972 are based on the Census data labeled "A-1 Other."

^d Par 46 (5.75" High- and Low-Beam) lamp data for 1967 through 1973 are adjusted Census data labeled "Under 6 Inches"

^e Par 56 (7.0" Twin-Beam) lamp data for 1967 through 1973 are adjusted Census data labeled "6 Inches and Over."

^f This column represents 1974 U.S. production of Par 46 rectangular lamps, as estimated by GE.

[†] These statistics (except for 1974 sales which were obtained through GE) were developed by: Statistics Department, Motor Vehicle Manufacturers Association, Detroit, Michigan 48202.

Shipping time for lamps sent 'direct' is nominal. An approximately 10 day backlog of headlights, or headlight assembly units, is maintained at each auto plant. In the remainder of this report total times used will be based on 'direct' shipments.

Delivery of assembled vehicles to auto dealers typically takes about 2 weeks. A vehicle may remain at the auto dealer for up to a month. Thus, the overall time between lens/reflector production and purchase of the car is about 1-4 months. The time interval, that may be of greatest interest to the forensic investigator—since it is the interval, that permits deduction of the model year of the vehicle—is the time between lens/reflector production and auto assembly. This interval is estimated to be about 4-10 weeks.

The above time estimates hold only for American-made cars. For vehicles assembled in Canada which use American-made headlights, or vice-versa, another week or 2 passes between lens/reflector molding and OEM installation. Volkswagen and other European and Japanese automakers import headlights from North America and install them in vehicles destined for export to the U.S. Time intervals for these vehicles are considerably lengthened. For the remaining vehicles imported into the U.S., headlights are installed after arrival in this country.

The evidential utility of headlamp glass in vehicle identification may be reduced if the broken lamp is not OEM. However, most headlights found on the road are OEM. The following rules-of-thumb may be helpful:

(1) If it can be ascertained that a lamp is less than 1.5 years old, the probability of it being OEM is about 90 percent. Once a lamp is deduced to be OEM, it follows that the motor vehicle is as old as the lamp (after subtracting a lamp assembly and delivery delay as described earlier in this section).

(2) If a lamp is more than 5 years old, it is also likely to be OEM;

(3) If a vehicle is deduced (by any means other than that involving headlamp glass) to be less than 3 years old, there is a greater than 95 percent probability that the lamp is OEM. A failure rate of less than 0.5 percent is claimed for a headlight's first year of normal service.

(4) If the lamp should turn out to be a replacement, the vehicle is likely to be more than 3 years older than the lamp.

3. VISIBLE FEATURES OF HEADLIGHTS

Each of the items listed in table 1 is discussed in order below.

3.1 Fluting Patterns

Headlight lenses have patterns consisting of a grid of ridges, or "flutings," embossed onto their inner surfaces. Each grid rectangle forms a prismatic wedge. This fluting pattern is pressed into the lens by a plunger. Each lampmaker uses a distinguishing set of fluting patterns which must conform to SAE/DOT standards.

A new plunger or mold produces a smooth, accurate finish. However, within a month or two of use, fine cracks develop in the plunger and mold, and the finished products becomes rough or distorted. Therefore, plungers are generally discarded or "rescaped" after about 40 hours of use. Since a plunger seldom remains in continuous use, the average life expectancy of plungers is on the order of six months. Both Corning and General Electric make many plungers for each prescription (see column 5, tables 9a, b, c, or d). Each plunger is numbered as described in paragraph 3.3. When a plunger is modified or rescaped, the plunger number will generally also be altered.

TABLE 9a. Interpretive data for code and plunger numbers on Corning 8100 Series, Par 46 (high beam) lenses

Code #	Lamp ^a Maker	Service Start	Period ^b		Plunger ^c # or Range	Matching ^d Lens Pattern	Comments ^e
				End ^f			
8102	Guide			5-64			"T3" in center of triangle NPC NPC, new platform NPC PC, added knurl to "T-3" monogram PC, "T-3" moved to bottom 1/4" flutes, "W" monogram Changed to "W" logo NPC, just aim pads PC "Tung-Sol" at bottom Without T-S, 1/4" flutes NPC PC To 1/8" flutes With TS, 1/4" flutes NPC platform change To 1/8" flutes 1/8" flutes NPC, just platforms Turnpike lamps not OEM "Power Beam" NPC, "Power Beam" NPC, "Power Beam"
8103	Guide	9-63		1-67			
8105	Guide	1-64		Obs.			
8106	Guide	11-9-65		5-68			
8107	Guide	5-24-67		12-67			
8108	Guide	12-67		7-72			
8109	Guide	3-3-71		7-74			
8110	Guide						
8102	West.	61		10-62	1-9		
8103	West.	62		4-65	10-15		
8104	West.	4-62		5-67	1-10		
8105	West.	66		Cur.	1-10	A45	
8106	West.	5-67					
<8108							
8108	T-S	3-10-64		1-67			
8110	T-S	2-66		2-67			
8112	T-S	5-13-66		4-74			
8114	T-S	10-12-71		Cur.			
8109	T-S	12-67		7-72			
8111	T-S	2-22-66		4-74			
8113	T-S	9-20-71			1-2	A30	
8113	T-S	72			3-5	A33	
8113	T-S	73		Cur.	6-10	A33	
8121	West.	12-63		Obs.	1-3		
8122	West.	4-65		72	1-3	A46	
8122	West.	73		Cur.	4,5		
8131	T-S	70		Obs.	1-3		
8132	T-S	7-70		71	1-3	A32	
8133	T-S	72		Cur.	1-7	A31	
8141	Guide	5-72		Obs.	1-18		
8142	Guide	12-72		73	19-23	A22	
8142	Guide	74		Cur.	24-28	A22	

TABLE 9a. Interpretive data for code and plunger numbers on Corning 8100 Series, Par 46 (high beam) lenses—Continued

Code #	Lamp ^a Maker	Service Start	Period ^b		Plunger ^c # or Range	Matching ^d Lens Pattern	Comments ^e
			Start	End ^f			
8171	West.	6-62	9-62		1-9		"FoMoCo"
8172	West.	9-62			1-9		
8172	West.	'63			10,11		
8172	West.	'64			10,11		
8173	West.	3-65	10-72				
8181	Atlas/W	5-62	1-63		1-4	NPC	
8182	Atlas/W	9-62	1-67		5,6	1/8" flutes NPC	
8183	Atlas/W	'69	Cur.		1	NPC	
8181	Atlas/T-S	11-62			1-5	1/8" flutes NPC	
8182	Atlas/T-S	11-19-64			1-5		
8182	Atlas/T-S	'65	5-68				
8183	Atlas/T-S	2-22-66	2-72			A55	
8184	Atlas/T-S	9-15-69			1-9	A56	
8184	Atlas/T-S	'70	73		1,2	A56	
8184	Atlas/T-S	'74	Cur.		3	A56	
8191	Atlas/T-S	6-30-71	Cur.		1-3		

^a And/or distributor.

^b Interval during which plungers, bearing the numbers in the column marked "Code #," could have been used. Where only the "Start" column contains a date the period described is just for that year. Generally one code # will be phased out (obsolete) many months after the subsequent plunger is entered into service.

^c The time period described. The plungers associated with a given "Service Period" may also be used in all subsequent service periods with matching Code # (and lamp maker).

^d These numbers or ranges relate to the (plunger) numbers pressed into the ~2 o'clock position on Corning lenses (Generally to the right of the "USA" marking), during these refer to the figures found in appendix A.

^e PC==Prescription Change; NPC==Non-prescription change (i.e., the pattern on this plunger is identical to that on the preceding plunger).

^f Obs.=Obsolete; Cur.=Current in 1974.

Turnpike lamp, same as 8133

TABLE 9b. Interpretive data for code and plunger numbers on Corning 8200 Series, Par 46 (low beam) lenses

Code #	Lamp ^a Maker	Service Period ^b		Plunger ^c # or Range	Matching ^d Lens Patterns	Comments ^e
		Start	End ^f			
8203	Guide	1960	10-62			¼" Flutes, "T-3" centered
8204	Guide	1-61	'63	1-23		PC
8205	Guide	5-28-62	5-64	1-23		NPC
8206	Guide	5-11-63	5-64	1-12	A24	NPC
8207	Guide	9-18-63	'65	38-53	A24	NPC, aim, plat. change
8208	Guide	9-24-63	5-68	54-64		NPC
8208	Guide	'66	5-68	1-10		PC
8210	Guide	3-7-67	5-68	10-46		PC, prismatic
8211	Guide	10-22-67	6-71			NPC
8213	Guide	9-30-68	6-69			"T-3" moved to bottom
8214	Guide	3-1-71	12-73			For Frigidaire, assume same as 8210
8212	Guide	12-21-67	6-69			
8203	West.	3-61	10-62	1-8		¼" flutes, "W" monogram & logo
8204	West.	4-62	10-63	9-13		Remove "W" monogram (same logo as 8271)
8205	West.	5-63	6-65	1-13		PC, prismatic
8205	West.	'65	'72	14-23	A49	PC
8206	West.	3-65		24-38		
8206	West.	'73	Cur.	39-40		
8206	West.	'74		41, 42		
8209	T-S	3-18-64	1-67		A36	"T-S" at bottom
8211	T-S	2-22-66	5-68			PC
8212	T-S	6-10-66	5-68		A37	PC
8214	T-S	12-12-67	4-74			PC
to 8233	T-S		5-68			
8210	T-S	2-22-66	5-68			W/O "T-S," presc. as 8209
8213	T-S	12-12-67	3-73			PC
to 8234	T-S		'64	1-6		¾" flutes
8221	West.	12-63	'71	1-6	A49	PC
8222	West.	3-29-65	Cur.	7, 8	A49	
8222	West.	'72		9, 10	A49	
8222	West.	'73				

TABLE 9b. Interpretive data for code and plunger numbers on Corning 8200 Series, Par 46 (low beam) lenses—Continued

Code #	Lamp ^a Maker	Service Period ^b		Plunger ^c # or Range	Matching ^d Lens Patterns	Comments ^e
		Start	End ^f			
8231	Guide	6-13-63	10-63			Frigidaire, crown & monogram For Frigidaire, but crown & mono removed NPC "Power Beam" PC, add "SAE H71"
8232	Guide	7-1-63	11-65			
8233	Guide	11-9-65	1-67	1-15		NPC "Power Beam" PC, add "SAE H71"
8231	Guide	6-9-70		16-22	A26	
8232	Guide	6-29-72		1-15	A26	
8232	Guide	'73		16-27		
8233	Guide	1-15-73	Cur.			
8233	Guide	'74				
8231	T-S	5-20-70	4-71	1-8	A39	$\frac{1}{8}$ " flutes, "T-S" at bottom PC
8232	T-S	9-18-70	71	9, 10		
8232	T-S	'72	12-73	1-8	A40	PC W/O "T-S," but otherwise prescrip- tion as 8233
8233	T-S	3-1-73	Cur.	9, 10		
8234	T-S	'74	Cur.			
8271	T-S	4-3-73	Cur.	1-7		West Prescript 8222 but "TS" at bottom, no USA "FoMoCo"
8271	West.	6-12-62	10-63			PC PC
8272	West.	5-20-63	1-67			
8273	West.	3-29-65	10-72	8, 9	A47	
8281	Atlas/W	9-4-62	5-64	1-5		$\frac{1}{8}$ " flutes PC
8282	Atlas/W	5-20-63	65	6, 7		
8283	Atlas/W	3-29-65	67	6, 7		PC, aim. platform change
8283	Atlas/W	'68	Cur.	8-11		
8281	Atlas/T-S	1-16-63	2-67			$\frac{1}{8}$ " flutes NPC, nubbin change PC PC
8282	Atlas/T-S	2-22-66	5-68		A57	
8283	Atlas/T-S	12-2-66	3-73		A59	
8284	Atlas/T-S	8-22-72	Cur.			

^a And/or distributor.

^b Interval during which plungers, bearing the numbers in the Column marked "Code #," could have been used. Where only the "Start" column contains a date the period described is just for that year. Generally one code # will be phased out (obsolete) many months after the subsequent plunger is entered into service.

^c These numbers or ranges relate to the (plunger) numbers pressed into the ~2 o'clock position on Corning lenses (generally to the right of the "USA" marking) during the time period described. The plungers associated with a given "Service Period" may also be used in all subsequent service periods with matching Code # (and lamp maker).

^d These refer to the figures found in appendix A.

^e PC = Prescription Change; NPC = Non-prescription change (i.e., the pattern on this plunger is identical to that on the preceding plunger);

^f Obs. = Obsolete; Cur. = Current in 1974.

TABLE 9c. Interpretive data for code and plunger numbers on Corning 8100 Series, Par 56 (6V, twin beam) lenses

Code #	Lamp ^a Maker	Service Period ^b		Plunger ^c # or Range	Matching ^d Lens Pattern	Comments ^e
		Start	End ^f			
8101	Guide	'60	6-69			Big "T-3," center of lens "Guide" at bottom of lens NPC PC, to Guide 8205 presc. Add "USA," PC "T-3" to bottom of lens Guide presc. 8261 with "12V" removed
8102	Guide	10-1-65	11-69			
8103	Guide	10-18-66	6-70			
8104	Guide	8-30-68		8-25		
8105	Guide	9-18-69	7-72	26-28		
8105	Guide	'70		9-11		
8106	Guide	5-14-71	Cur.	12		
8106	Guide	'72				
8106	Guide	1-15-73	Cur.			
8161	Guide					

^a And/or distributor.

^b Interval during which plungers, bearing the numbers in the column marked "Code #," could have been used. Where only the "Start" column contains a date the period described is just for that year. Generally one code # will be phased out (obsolete) many months after the subsequent plunger is entered into service.

^c These numbers or ranges relate to the (plunger) numbers pressed into the 2 o'clock position on Corning lenses (generally to the right of the "USA" marking), during the time period described. The plungers associated with a given "Service Period" may also be used in all subsequent service periods with matching Code # (and lamp marker).

^d These refer to the figures found in appendix A.

^e PC = Prescription Change; NPC = Non-prescription change (i.e., the pattern on this plunger is identical to that on the preceding plunger).

^f Obs. = Obsolete; Cur. = Current in 1974.

TABLE 9d. Interpretive data for code and plunger numbers on Corning 8200 Series, Par 56 (6, 12V) (twin beam) lens

Code #	Lamp ^a Maker	Service Periods ^b		Plunger ^c # or Range	Matching ^d Lens Pattern	Comments ^e
		Start	End ^f			
8201	Guide	<60	65	22	A27	"T-3" in center, 1/4" flutes PC, "Guide" at bottom
8202	Guide	6-20-61	Obs.			
8203	Guide	10-1-65	6-69			
8204	Guide	10-18-66	6-69			
8205	Guide	8-30-68	3-70			
8206	Guide	9-18-69	7-72			
8207	Guide	5-14-71	Cur.			
8204	T-S		Obs.			
8205	T-S	60	9-62	1-11 12-15		NPC PC Added "USA" otherwise NPC "T-3" to bottom, otherwise NPC "Tung-Sol" at bottom, 1/4" flutes, no monogram PC NPC, but add "USA"
8206	T-S	4-4-61	62			
8206	T-S	63	11-63	30-48 49-56 58-61 62-64	A41 A41 A41 A41	NPC except "USA" "Tung-Sol" out, "T-S" in PC NPC PC
8208	T-S	8-1-63	9-64			
8210	T-S	3-26-64	1-65			
8212	T-S	1-19-65	2-68			
8214	T-S	2-22-66	2-68			
8216	T-S	1-20-67				
8216	T-S	'70				
8216	T-S	'71				
8216	T-S	'72				
8216	T-S	'73				
8218	T-S	5-22-73	4-74	PC Unmarked, 1/4" flutes "Tung-Sol" out, "T-S" in Similar to 8210 NPC PC		1/4" flutes, "W" logo + mono
8207	T-S	12-29-61	Cur.			
8209	T-S	2-5-64	5-64			
8211	T-S	9-25-64	6-66			
8213	T-S	2-2-66	1-67			
8217	T-S	1-20-67	2-68			
8219	T-S	7-30-73	4-74			
8219	T-S		Cur.			
8201	West.	<60	'61	2-17-61		New "W" in center Monogram out
8202	West.		'61			
8203	West.		6-61			
8204	West.		3-62			
8205	West.					
8206	West.		3-62			

TABLE 9d. Interpretive data for code and plunger numbers on Corning 8200 Series, Par 56 (6, 12V) (twin beam) lenses—Continued

Code #	Lamp ^a Maker	Service Periods ^b		Plunger ^c # or Range	Matching ^d Lens Pattern	Comments ^e
		Start	End ^f			
8207	West.	3-22-61	3-62			Went to 1/8" flutes
8208	West.	3-27-61	3-62			Unmarked
8209	West.	5-16-61	9-63		A53	NPC, same as 8207
8210	West.	9-19-63	9-64		A53	NPC, same as 8207
8211	West.	8-24-64	Obs.		A53	PC
8212	West.	8-3-65	Obs.		A53	NPC
8213	West.	1-31-66	6-69	74-80	A53	PC
8214	West.	1-20-69		81-84	A53	
8214	West.	'70		85-89	A53	
8214	West.	'71		90-95	A53	
8214	West.	'72		96-99	A53	
8214	West.	'73		1-3		
8214	West.	'74	Cur.	4-11	A53	
8221	West.	12-31-63	1-65		A54	1/8" flutes, "Westinghouse" at bot- tom
8222	West.	8-24-64	Obs.		A54	NPC
8223	West.	12-7-65	Cur.		A54	NPC
8231	Guide/Frig.	6-13-63	10-63			Frigidaire logo in center
8232	Guide/Frig.	7-1-63	6-66			Removed crown & "F" from mono- gram
8231	T-S	3-11-70	12-73		A42	1/8" flutes, "T-S" at bottom
8232	T-S	5-22-73	12-73		A43	PC
8233	T-S	8-3-73	Cur.			PC
8234	T-S	9-3-74	Cur.			Like 8233 but unmarked
8251	Guide	7-14-69	4-74		A28	"Power Beam" 1/4" flutes, "Guide" at bottom
8253	Guide	12-17-73	Cur.		A28	PC
8261	T-S for Guide	2-2-71				
8262		10-13-73	Cur.			Guide logo, "T-S" presc. 8216

TABLE 9d. Interpretive data for code and plunger numbers on Corning 8200 Series, Par 56 (6, 12V) (twin beam) lenses—Continued

Code #	Lamp ^a Maker	Service Periods ^b		Plunger ^c # or Range	Matching ^d Lens Pattern	Comments ^e
		Start	End ^f			
Marked 8261	W for T-S	10-3-72	Cur.			West. presc. 8223
8271	W for Guide	6-7-74	Cur.			Guide logo, West. presc. 8214
8271	West.	6-17-64	9-64		A52	"FoMoCo," West. presc. 8210
8272	West.	8-22-64	Obs.		A52	NPC
8273	West.	1-31-66	4-73		A52	NPC
8281	Atlas/W	5-2-62	9-63			1/8" flutes
8282	Atlas/W	7-1-63	6-65			NPC
8283	Atlas/W	8-24-64	Obs.			NPC
8284	Atlas/W	1-31-66				NPC
8281	Atlas/T-S	11-8-62	11-63			1/8" flutes
8282	Atlas/T-S	9-5-63	11-67			NPC
8283	Atlas/T-S	2-22-64	Obs.			NPC, except "USA" removed
8284	Atlas/T-S	1-20-67	5-74			PC
8295	Atlas/T-S	5-22-73	Cur.		A60	PC
8290	Norel	9-16-74	Cur.			West. presc. 8214, "W" at upper left, "Norel" at bot.

^a And/or distributor.

^b Interval during which plungers, bearing the numbers in the column marked "Code #," could have been used. Where only the "Start" column contains a date the period described is just for that year. Generally one code # will be phase out (obsolete) many months after the subsequent plunger is entered into service.

^c These numbers or ranges relate to the (plunger) numbers pressed into the 2 o'clock position on Corning lenses (generally to the right of the "USA" marking), during the time period described. The plungers associated with a given "Service Period" may also be used in all subsequent service periods with matching Code # (and lamp maker).

^d These refer to the figures found in appendix A.

^e PC = Prescription Change; NPC = Non-prescription change (i.e., the pattern on this plunger is identical to that on the preceding plunger).

^f Obs. = Obsolete; Cur. = Current in 1974.

The wide diversity of sealed beam fluting patterns is seen from the lens illustrations presented in appendix A. If a sufficiently large piece of headlight can be recovered and examined, it may be possible to identify the fluting pattern. A fluting pattern can generally be associated with a lampmaker, a lamp type (high, low or twin-beam) and an age range on the order of a few years (see tables 10 and A1). Once lamp type and lamp age have been determined, tables 6 and 7 may be used to narrow down the possible makes, models, and model-years of a vehicle.

Prior to 1962, all headlights used $\frac{1}{4}$ " wide flutes.¹ Starting in 1962, Atlas lamps were made with $\frac{1}{8}$ " flutes. Between 1962 and 1972, Westinghouse converted various members of its headlight family (including Atlas) to $\frac{1}{8}$ " flutes. Tung-Sol began using $\frac{1}{8}$ " flutes in 1970, and in mid-1972 Ford began using $\frac{1}{8}$ " flutes in its passenger vehicle headlights. Ford trucks, however, still use $\frac{1}{4}$ " flutes. In early 1974, Chrysler introduced $\frac{1}{8}$ " flutes into some of its models. GM (Guide Lamp) still uses only $\frac{1}{4}$ " flutes (note figs. A20 through A29). AMC currently uses T-S lamps which have $\frac{1}{8}$ " flutes.

The number of Corning lens prescriptions for the past 10 years, including all major and minor modifications, is estimated to be about 75. Of these, appendix A contains representations of about 40 unique patterns. Those Corning fluting patterns not included in appendix A represent, for the most part, older prescriptions or minor modifications to recent patterns. No examples of Atlas/Westinghouse lamps could be obtained.

3.2 Logos

All recently manufactured headlights designed for use in American passenger vehicles include the manufacturer's name or trademark on the lens in accordance with SAE Standard J571c.

3.2.1 Guide

In 1963, Guide lamps had a triangle in the center (e.g., figures 1a and A23). In 1971, the triangle was removed and "T-3" "GUIDE" was located in the bottom of the lens (figs. 1b and A25). The "T-3" was subsequently removed and a circle containing the words "POWER BEAM" was embossed on the inner surface of the center of the lens (figures 1c and A26). Headlights having this last change were used on 1970 Monte Carlos having 7" lenses, on all 1973 GM models having 7" lamps and on all 1973 GM models having type 1 or 2, Par 46 lamps.

3.2.2 Westinghouse

The genealogy of Westinghouse lamps is displayed in figures 2a and 2b. Modifications made in the Westinghouse monogram design and position are dated in these figures. Correspondence between these modifications and changes in Westinghouse lamp code numbers given in tables 9a, b, c and d should be apparent. Lens drawings and schematics for selected Westinghouse lenses, and specifications for early Westinghouse logos. The designs of selected Westinghouse lenses are presented in appendix B. Details for early Westinghouse logos are shown in figures 3a and 3b. Details of the beam-type markings on Westinghouse lenses, as discussed in section 3.4, are found in figure 4.

¹ The spacing between vertical grooves in a lens pattern.

TABLE 10. Lens mold data for Corning lenses

Par 46 Lamps				Par 56 Lamps			
Mold Letter	# of Molds With Letter	Time Interval During Which Lamps Received "	Comments	Mold Letter	# of Molds With Letter	Time Interval During Which Lamps Received	Comments
		Start Stop				Start Stop	
B		1-58	Guide Lamp Specific	A		7-58	Guide Lamp Specific
C		1-58	Guide Lamp Specific	B		12-58	Guide Lamp Specific
C		7-58	Guide Lamp Specific	K		1-59	Guide Lamp Specific
H		8-58	Guide Lamp Specific	D		8-59	Guide Lamp Specific
E		8-58	Guide Lamp Specific	C		8-59	Guide Lamp Specific
F		1-59	Guide Lamp Specific	E		12-59	Guide Lamp Specific
J		5-59	Guide Lamp Specific	A		5-60	Guide Lamp Specific
K		12-59	Guide/T-S' Specific	F		12-60	Guide Lamp Specific
F		1-60	Guide/T-S' Specific	G		11-61	Guide (+ T-S?) Specific
D		10-58	T-S Specific	O		6-58	T-S Specific
C		2-58	T-S Specific	P		7-58	T-S Specific
E		8-59	T-S Specific	M		8-58	T-S Specific
O		10-59	T-S Specific	N		2-59	T-S Specific
B		10-58	Westinghouse Specific	R		5-59	T-S Specific
C		10-58	Westinghouse Specific	S		11-59	T-S Specific
D		3-59	Westinghouse Specific	T		2-60	T-S Specific
E		7-59	Westinghouse Specific	E		3-58	Westinghouse Specific
F		2-60	Westinghouse Specific	F		12-58	Westinghouse Specific
N		'61	Westinghouse Specific	G		3-59	Westinghouse Specific
L		'61	Westinghouse Specific	H		10-59	Westinghouse Specific
M		'61	Westinghouse Specific	I		~5-60	Westinghouse Specific
J				J		9-60	Westinghouse Specific
K				K		1-61	Westinghouse Specific

TABLE 10. Lens mold data for Corning lenses—Continued

			Par 46 Lamps				Par 56 Lamps			
Mold Letter	# of Molds	Time Interval During Which Lamps Received ^a	Comments	Mold Letter	# of Molds	Time Interval During Which Lamps Received		Comments		
						Start	Stop		Start	Stop
L	114	6-64	Guide/T-S Specific	E		3-61		Westinghouse Specific		
M	65	11-64	Guide/T-S Specific	A		'61				
N	130	2-65	Guide/T-S Specific	B		5-62				
D	65	12-64	Universal Molds (?)	A	93	'63	'64	Guide Lamp Specific		
E	131	6-65	Universal Molds	B				Guide Lamp Specific		
F	112	12-65	Universal Molds	C				Guide Lamp Specific		
G	126	6-66	Universal Molds	A	62	11-64	4-65	Westinghouse Specific		
J	124	3-67	Universal Molds	B		6-63		Westinghouse Specific		
I	121	10-67	Universal Molds	C				T-S Specific		
K	127	1-68	Universal Molds	D				T-S Specific		
L	62	5-68	Universal Molds	E				T-S Specific		
M	119	9-68	Universal Molds	F			2-65	T-S Specific		
P	116	12-68	Universal Molds	G	67	12-65		Universal Molds		
R	134	3-69	Universal Molds	H	131	5-66	6-66	Universal Molds		
S	98	5-69	Universal Molds	I	129	8-67		Universal Molds		
T	129	9-69	Universal Molds	J	63	5-68		Universal Molds		
V	100	12-69	Universal Molds	K	102	5-69	8-69	Universal Molds		
A	31	11-69	Universal Molds	L	68	12-69		Universal Molds		
A	125	10-70	Universal Molds	M	125	6-70	7-70	Universal Molds		
B	129	5-71	Universal Molds	A	124	12-71	3-72	Universal Molds		
C	135	11-71	Universal Molds	B	127	6-72	8-72	Universal Molds		
D	57	6-72	Universal Molds	C	117	8-73	10-73	Universal Molds		
E	57	6-72	Universal Molds	D	138	4-74	Cur.	Universal Molds		
F	60	11-72	Universal Molds	E	120	9-74	11-74	Universal Molds		
G	32	1-73	Universal Molds					Not run as of 12-74		
A	31	1-73	Universal Molds							
B	144	3-73	Universal Molds							
C	122	6-73	Universal Molds							
D	134	1-74	Universal Molds							
E	118	2-74	Universal Molds							

^a This is the interval during which molds bearing the associated letter were received by the lampmaker. The time interval during which lenses were actually pressed with these molds (i.e., the 'effective' interval) is, of course, somewhat later. That is, the effective start times should be shifted to about one month later and effective stop times can be up to a year beyond the dates given.

^b Cur. = Current as of 12-74.

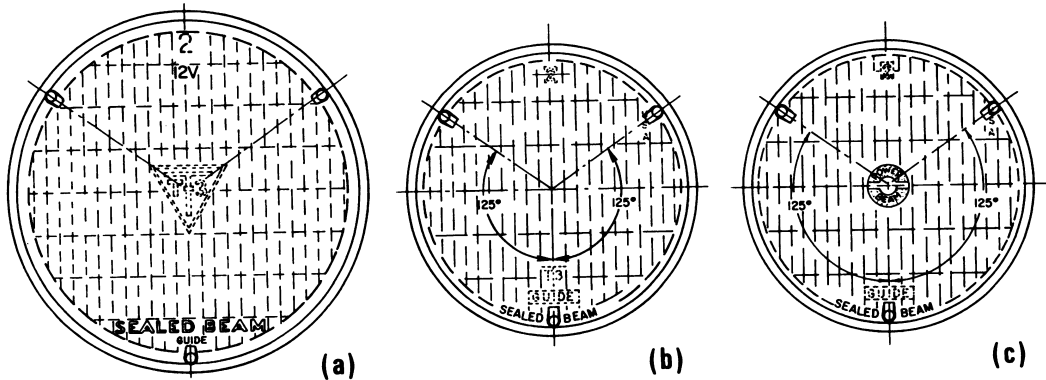

FIGURE 1. (a) Pre-1961 Guide headlamps; (b) 1963-70 headlamps; and (c) Recent Guide lamps.

3.2.3 General Electric

From 1953 until 1956, General Electric embossed a 1" logo in the center of each 7" lens (e.g., figure A10). In 1956, GE changed to a $\frac{9}{16}$ " logo centered on each 7" lens as in figure A11. Some of these lenses also have the words "All Weather" embossed in script letters, just above the "SEALED BEAM" inscription. The present General Electric logo, shown for example in figures A9 and A15, became standard beginning in 1961. The dimensions of this logo are given in figures C1 and C11 for Par 46 and 56 lamps, respectively.

Seven-inch lenses made at GE's Mahoning plant for use in Canada were an exception. From about 1968 until 1973, some such lenses were pressed without any GE logo (as in figures A13 and A14). Those unlabeled lenses had a $\frac{9}{16}$ " GE logo sandblasted into them, as shown in figure A12. In late 1973, such logos on their 7" lamps were phased out in favor of the standard embossed GE logo.

3.2.4 Tung-Sol

Prior to 1961, the TUNG-SOL logo was formed by molds, so that the letters appeared raised on the outside at the bottom of the lenses. In 1961, their logo was transferred to plungers, so that "TUNG-SOL" was depressed on the inside bottom of the lenses, as in figure A35. Starting in 1964 and continuing to the present, Tung-Sol lamps are pressed with a "TS" monogram just above the words "SEALED BEAM" on the inside of the lenses, as in figure A36. This TS logo is enclosed in a 0.38" circle. Some Tung-Sol lenses contain no logos (see, for example, fig. A34). These lenses are for incorporation into lamps to be distributed under a trademark other than Tung-Sol.

3.2.5 Atlas

There are several companies (e.g., Sears, Atlas, Eveready, etc.) that market or distribute auto headlights made by one or more of the big four American lampmakers. Of these, only the Atlas Supply Company has its lamps specifically embossed with its logos. These lamps, made for Atlas by General Electric, Tung-Sol or Westinghouse, are used primarily as replacement equipment. A major distributor of Atlas lamps is the Standard Oil Company.

WESTINGHOUSE ELECTRIC CORP.
SPECIALTY LAMP DIVISION
SEALED BEAM HEADLAMPS
PAR 46 LENS CHANGES
6-21-74 J.S. GORECKI

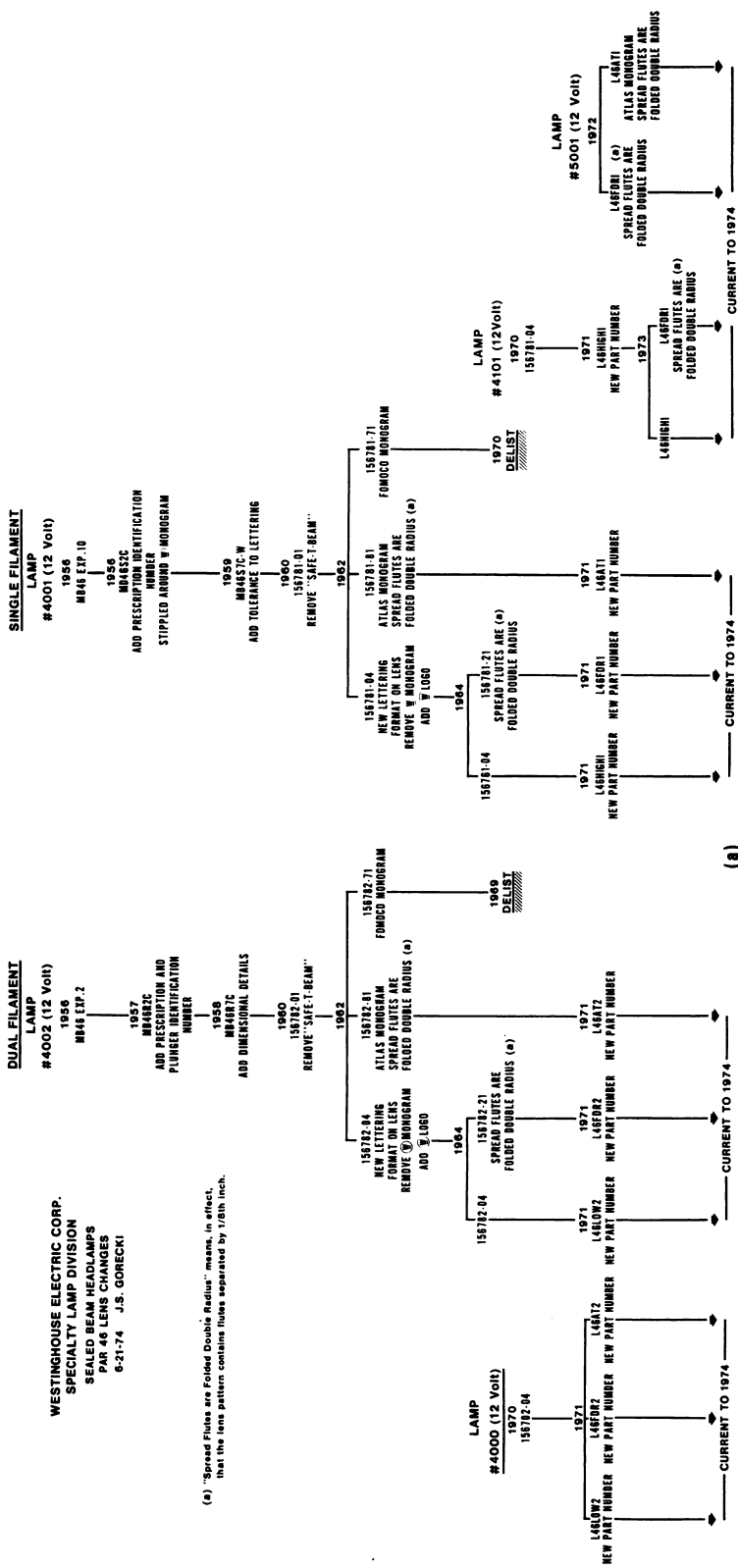

(a) "Spread Flutes are Folded Double Radius" means, in effect, that the lens pattern contains flutes separated by 1/6th inch.

FIGURE 2a. Genealogy of Westinghouse PAR 46 sealed beam headlamps.

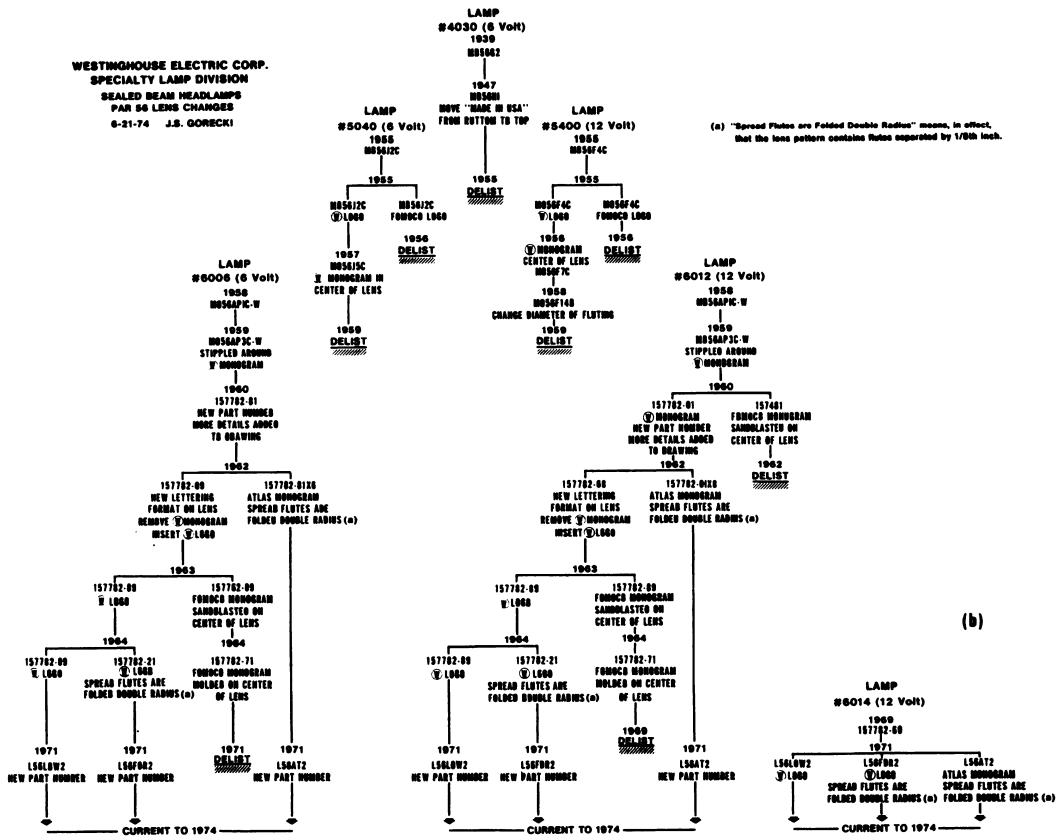

FIGURE 2b. Genealogy of Westinghouse PAR 56 sealed beam headlamps.

Atlas lenses have an Atlas logo pressed into the center. Typically, the lampmaker's logo is imprinted at the bottom of the lens—just above the words "SEALED BEAM." Examples of the Atlas logo are shown in figures A55 through A64, figures B10 and B11, and figures C7 and C14.

3.2.6 Ford

From about 1955 until about mid-1971, all Ford motor vehicles had OEM sealed beam lamps with a "FoMoCo" logo, made by General Electric, Tung-Sol or Westinghouse. At that time, these lamps were phased out in favor of standard lamps. Replacement lamps carried by authorized Ford service stations also carried the FoMoCo logo. The phasing out of these replacement lamps probably took one to two years.

In some cases (see figs. A44 and A52, for example), the Ford logo was embossed onto the front surface of the lens by means of special molds. Dimensions of this logo found on Westinghouse lamps made for Ford are found in figures B18 and B22. In other cases (see, for example, figures A1, A35 and A36), the logo was etched or sandblasted onto the outer surface of the lens using Ford's in-house facilities.

3.3 Mold, Plunger and Other Lens Markings

General Electric and Corning use additional markings to identify their lenses.

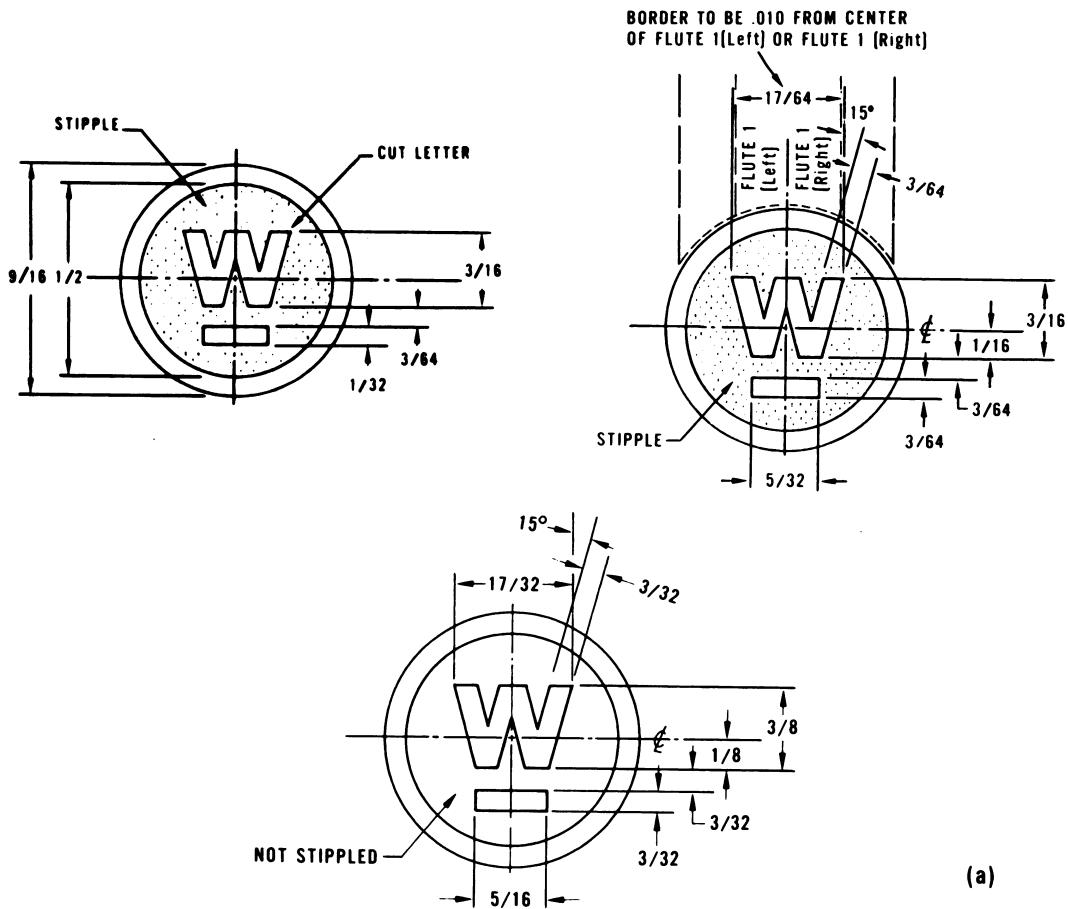

FIGURE 3a. *Westinghouse logo details (all dimensions are in inches).*

Monogram used on Westinghouse 4001, 4002, and 5400 lamps from 1956 to about 1959. During the first part of this period the area within the ($\frac{1}{2}$ " circle was probably not stippled.
 Monogram used on Westinghouse 4002 (and probably 4001 and 5400) lamps from about mid-1959 until April 1962.
 Monogram used on Westinghouse 6006 and 6012 lamps from about February 1959 until May 1962. During the first part of this period the central region was not stippled. From June 1959 until the end of this period the area within the circle was stippled.

3.3.1 General Electric's Lens Markings

General Electric lenses generally have identifying markings at the 10, 12 and 2 o'clock positions (see figures in appendix C). Lenses pressed in Somerset, Kentucky, for assembly in Lexington, Kentucky, have the letters "USA" embossed onto their inner (plunger) surfaces at the 10 o'clock position. However, lenses made at General Electric's Mahoning plant (Niles, Ohio) usually are either special types, or are destined for assembly in Canada, and generally are not embossed "USA". Canadian General Electric (CGE) lamps may still find their way back to the U.S. when installed in Canadian-assembled Ford, Chrysler, AMC or Volkswagen vehicles. Each year Canada exports from 800,000 to one million motor vehicles to the U.S. For example, table 3 shows that about 50 percent of the VW's use GE lamps as OEM. These are usually CGE lamps.

* For .

not shown, see MB56F14C-W

BORDER TO BE .010 FROM CENTER
OF FLUTE 1 (Left) OR FLUTE 1 (Right)

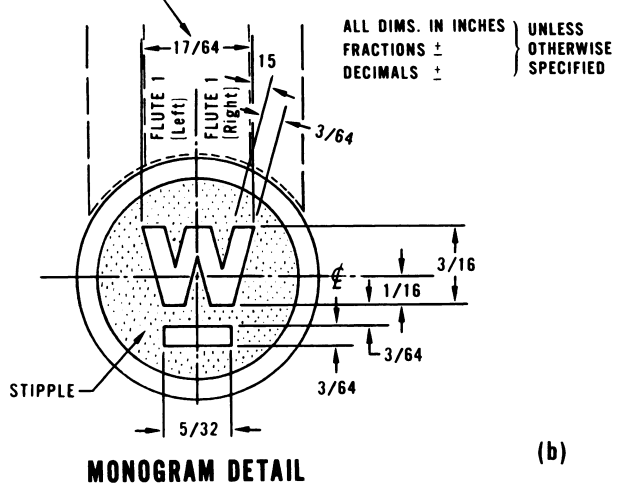
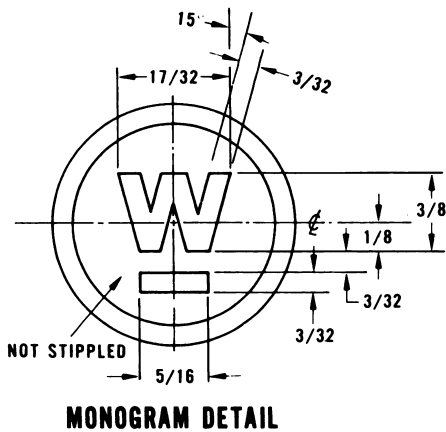

FIGURE 3b. Additional Westinghouse logo details.
Center monogram used on Westinghouse 6006 and 6012 lamps from February 1968 to present.
Center monogram used on Westinghouse 4001 and 4002 lamps from 1956 to April 1962.

A mold number is embossed onto the outer 12 o'clock position of all GE sealed beam lenses. These numbers generally run through alphabetic cycles (see table 10). Since GE keeps logs on when each mold is put in or taken out of service, and since the lifetime of a mold ranges from about 3 months to a year, the mold number plus the degree of firecracking can be used to estimate the date that a lens was formed, to within about three to four months.

A plunger number can be found at the 2 o'clock position on the inner surface of all GE lenses. Each plunger is given a unique number, placed within a flute, which consists of several parts:

- (1) A letter designating the GE plant at which the lens was formed. An "S" designates the Somerset, Kentucky, plant; an "M" designates the Mahoning plant.
- (2) The next letter or two defines the basic lamp prescription or type, thus:

Designation	Lamp Type
N	4001/4006
P	4000/4002/4005
ZA	6006/6012/6013/6014/6015
ZE	Special 6012 prescription
X	Experimental design

An "X" will generally be followed by a number which corresponds to a prescription drawing for the lens. Parts 3 and 4 below do not appear on experimental lenses.

(3) The next two or three digit number identifies the plunger, and the appropriate prescription drawing. Each number is assigned sequentially in GE's Cleveland plant where the GE plungers are made. Thus, the portion of a lens containing the GE plunger number indicates the lampmaker, the location of the fragment, the fluting pattern and the lamp type.

(4) Occasionally a basic lens prescription or plunger is modified to improve its performance or its conformance with the SAE/DOT standards. If the modification is minor, the change is noted on the drawing, and indicated on the plunger by the addition of a number or letter in the flute adjacent and to the right of that containing the basic plunger number.

Dots above the number or letter in the right adjacent flute indicate additional modifications to the lens prescription. Dots under a "Z" indicate subsequent plunger rescrappings.

The "code" number, usually located near the left-side aiming pad at the 10 o'clock position, consists of a three part format: [8] [X] [YZ]. The "8" indicates that it is a sealed beam headlamp. "X" refers to the beam type: X=1, high beam—probably a 4001 or 5001 lamp; X=2, low or twin beam—a 4000, 4002, 6006, 6012, 6013, 6014, or 6015 lamp. "YZ" refers to a specific lens prescription drawing. Corning's present code numbers and their evolution over the past decade are detailed in tables 9a through 9d.

The "mold" number is found directly above the beam number at the 12 o'clock position, and consists of an alphabetic character followed by a one to three digit number. The letter refers to the general mold prescription (e.g., Par 46, 56, etc.), while the subsequent number is unique for each mold. Mold data which could be obtained from Corning are listed in table 10 and are plotted in figure 5. Dates on which specifically labeled molds were either received or retooled are shown. Separate molds were used to press Guide, Tung-Sol and Westinghouse lenses until 1961, since each of these lampmakers required distinctive aiming pad configura-

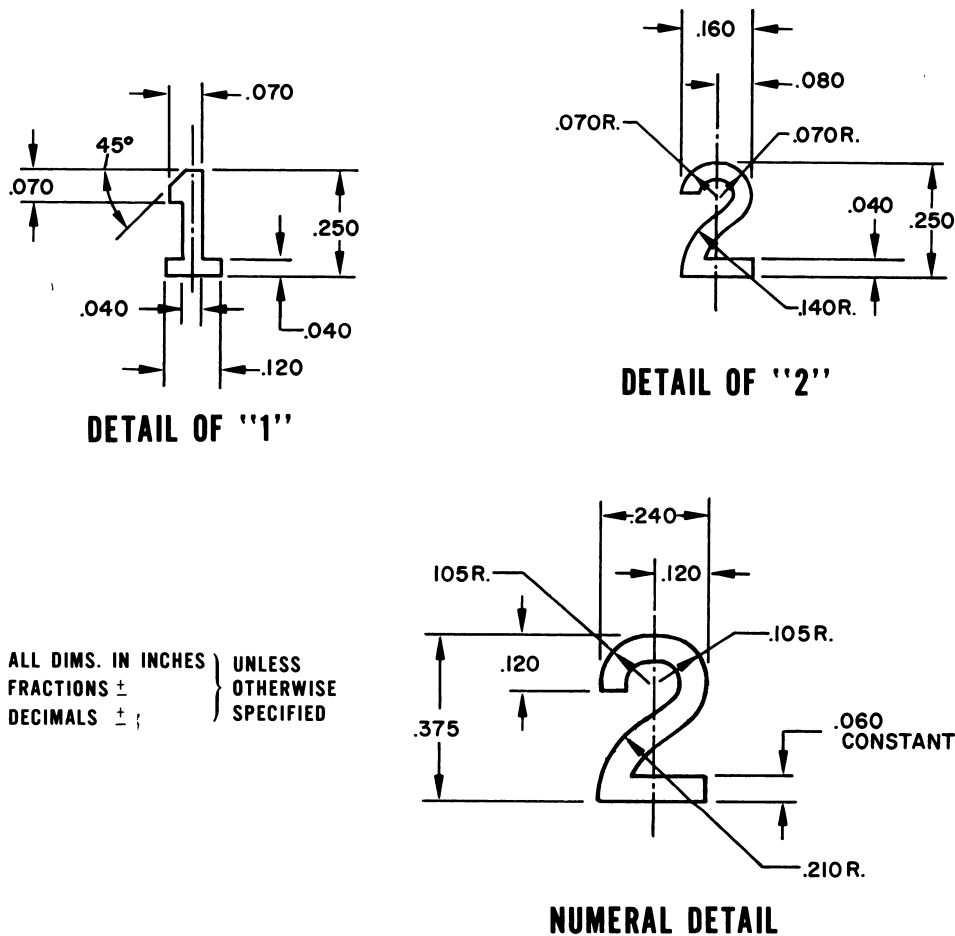

FIGURE 4. Dimensions of "1" and "2" on Westinghouse lamps.

Detailed drawings of "1" and "2" numerals used in Westinghouse 4001 and 4002/4000 lamps, respectively. These drawings apply for time period from 1956 to the present.
 Detailed drawings of "2" numeral appearing in all Westinghouse 6006, 6012 and 6014 lamps since 1958.

tions or dimensions. The situation between 1961 and 1964 is unclear. After 1964, Corning molds were "universal," i.e., any mold could be used with any plunger as long as both were Par 46 or 56. The first mold that is cut in conformance with prescription 'A' is, typically, given the mold number A1, and so forth. The total mold number thus uniquely identifies a mold. Upon request Corning will provide specific dates for which any mold was placed in service and was subsequently retired. This information should permit dating a lens to with ± 3 months, since a mold generally remains in service approximately six months.

The letters "USA" typically appear at the 2 o'clock position below the right side aiming pad of Corning's Westinghouse and Guide lenses. In 1969, Guide added the "USA" to its headlamp prescriptions. Since 1964, Tung-Sol lenses, including those made by Tung-Sol for Atlas, have not carried this inscription.

The plunger number is located in the flute adjacent and to the right of the USA inscription. On Tung-Sol lamps, it is below the aiming pad. There may be several plungers made to a single prescription. These plungers generally remain in service for three months to a year. Corning engineers can, in some cases, supplement the data presented in tables 9a through 9d.

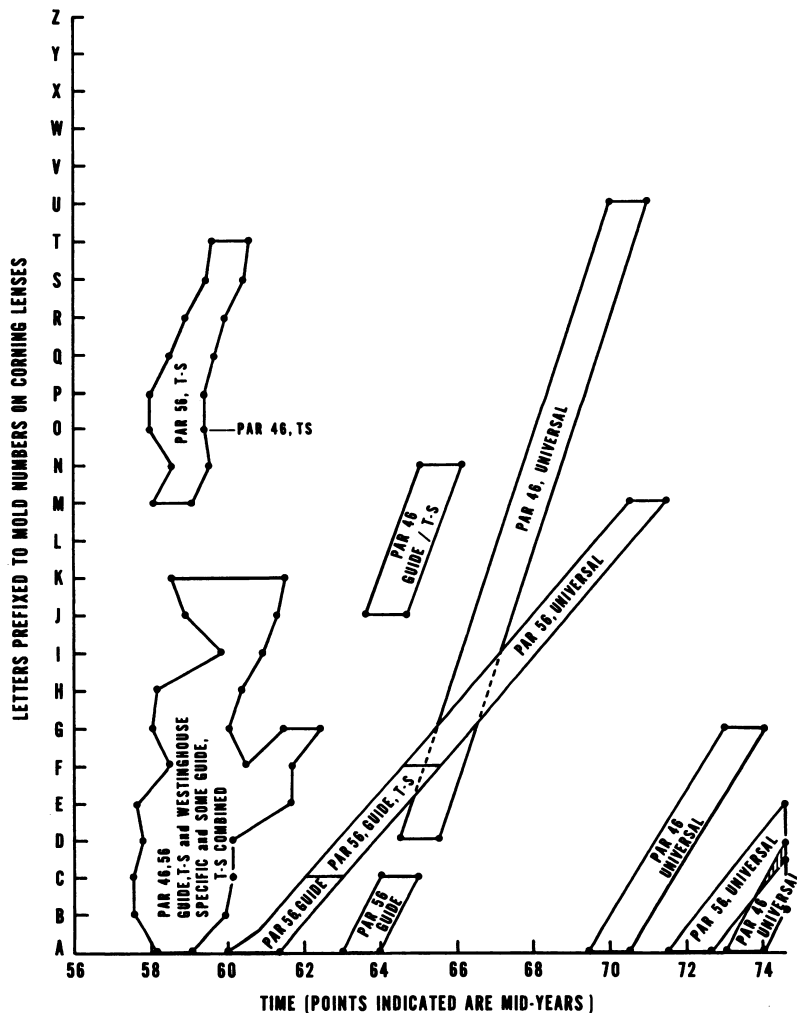

FIGURE 5. Time distributions for the alphabetic prefixes to Corning's PAR 46 and PAR 56 lens molds numbers (based on the data in table 10).

3.3.2 Corning's Lens Markings

Descriptions of Corning-made lenses are sometimes complicated by variations produced by Corning's associated lampmakers or distributors. As with GE, Corning lenses typically are embossed with three sets of markings in the 10, 12 and 2 o'clock positions. A fourth marking in the 4 o'clock position is peculiar to some Guide lamps. Examples of these markings can be noted in the Corning lenses illustrated in appendix A.

The inscription "SAE" is embossed by the plunger within a flute at the 4 o'clock position of some recent Guide lamps. The letter "H", designating a SAE headlamp standard, is embossed in the right adjacent flute followed by the year of the SAE standard with which the lens prescription and lamp construction comply. These standards are infrequently modified. Therefore, the embossed year may be earlier than the production year by as many as four or more years. Typically, however, the difference between embossed and production years is one to two years.

3.4 Beam-Type Markings

SAE Standard J571c contains the requirement that all sealed beam headlamps show, at the top of each lens, the type of beam it contains (i.e., either '1'—high-beam, or '2'—low- or twin-beam). The beam-type number is typically produced by the plunger and, therefore, is embossed on the inner surface of each lens. The general dimensions of these numerals are:

Beam-Type Numeral	Type Beam	Lamp Diameter	Numeral Height
"1"	High	5.75"	0.250" ± 0.031"
"2"	Low	5.75"	.250" ± .031"
"2"	Twin	7.03"	.375" ± .031"

Additional dimensions of these numerals for Westinghouse lamps are shown in figure 4.

3.5 Curvature

Lens curvature can be used to distinguish headlight glass from other types of glass. The three principal brands of headlights have external surface curvatures either between 4.94'' and 5.18'', or between 6.00'' and 6.125'' in accordance with SAE Standard J571c. For example, Corning aims for radii of curvature of 5.00'' and 6.125'', respectively.

The curvature may be determined with an inexpensive instrument called a lens gauge, used by lens makers and opticians. Lens gauges are also referred to as "lens clocks," "diopometers," "diometers" or "lens measures." They are available in sizes that permit measurement of lens fragments as small as 0.5'' in length.

3.6 Headlight Aiming Pads

Aiming pads project from the lenses of headlights, and are used for aligning headlights to obtain correct lighting patterns. They are referred to by the industry as "aiming points," "aiming platforms," "nubbins" or "gizmoses." SAE Standard J571c requires these pads, and specifies their dimensions and positions. They were adopted by the entire headlight industry about 1955.

Until 1961-64, Corning used different sets of molds for Guide, Tung-Sol and Westinghouse lenses. After 1964, universal molds were used at Corning. Most Corning-supplied lenses have teat-shaped pads. General Electric, Lucas, Koito, Stanley and Toshiba pads are wedge

shaped. Illustrations and specification sheets for Westinghouse and GE lenses give aiming pad positions and dimensions, and are shown in appendices B and C, respectively. Tung-Sol changed from thick cross-section pads to slim, tapered ones in 1966.

Guide lamps, whether for original or replacement use, have their pads ground flat. To see the difference grinding makes, compare figures A25 and A26. Lens #49 in figure A26 does not have its pads ground flat, since it was never incorporated into a lamp. Grinding the pads flat facilitates headlamp alignment by means of special GM equipment. Westinghouse also grinds some of their lamp pads, (e.g., lens #105, figure A44), but these may be the exception rather than the rule.

Lamps which are not intended for use as headlights in automobiles (e.g., spot or fog lights or lamps for motorcycles) do not have these pads.

3.7 Reflector Markings

Reflectors generally have a mold number, similar in origin and utility to a lens mold number, and an inked imprint containing some or all of the following information: lamp-maker's identity, type of lamp, lamp voltage, month and year of lamp assembly, year of SAE or DOT Standard with which the lamp conforms, and where the lamp was assembled.

From 1940 through 1963, General Electric used the following code to date their sealed beam headlights:

Year	'56 '48 '40	'57 '49 '41	'58 '50 '42	'59 '51 '43	'60 '52 '44	'61 '53 '45	'62 '54 '46	'63 '55 '47
CODES								
Jan.	1	13	25	37	49	61	73	85
Feb.	2	14	26	27	50	62	74	86
Mar.	3	15	27	39	51	63	75	87
Apr.	4	16	28	40	52	64	76	88
May	5	17	29	41	53	65	77	89
June	6	18	30	42	54	66	78	90
July	7	19	31	43	55	67	79	91
Aug.	8	20	32	44	56	68	80	92
Sept.	9	21	33	45	57	69	81	93
Oct.	10	22	34	46	58	70	82	94
Nov.	11	23	35	47	59	71	83	95
Dec.	12	24	36	48	60	72	84	96

Starting in 1963 and continuing to the present time, the GE date coding has consisted of three groups of characters. The first marks are numbers referring to the month of manufacture, numerically from 1 to 12. The second mark is either a dot (·) representing the Trumbull Lamp Plant or a dash (—) representing the Lexington Lamp Plant. The third mark is the year of manufacture, using only the last digit of the year. The decade of manufacture must be ascertained by some other means. For example: "4-3," signifies that the lamp was made at the Lexington, Ky., plant in April 19 3.

Westinghouse's date codes are similar to General Electric's, except that in some cases the date is printed in the form X-DOT-Y.

Tung-Sol date codes generally are of the form XY, where X is the alphabetic equivalent of the production month and Y is the last digit of the year. The letter I is never used, so September, October, November and December are J, K, L, and M, respectively.

Guide's date codes are in the alphanumeric sequence [X] [A] [Y] [B] [C]. X represents the production month. For January through September, X takes the values 1 through 9, respectively. For the remaining months, the letters O, N, and D are used. Y is the last digit of the production year. A, B, and C refer to production lines and work shifts.

3.8 Color

Sealed beam headlight glass must be "white," to conform with SAE Standard J578. Thus colored or non-clear glasses probably are not from headlights. Amber or red glass may occur in foglights or signal lamp covers. Almost all external automotive light covers (i.e., for tail, back-up, brake, side or signal lights) on recent models are made of plastic, not glass.

Appendix A—Photographs of Headlight Lenses

The illustrations presented in this appendix represent a significant cross-section of the lens patterns that have been used in domestic passenger vehicle headlights in the last ten or so years. Most lens patterns not presented have only minor modifications from those included.

Through the identification of a lens pattern in appendix A, and the use of columns 7 and 8 of table A1, it may be possible to date a lens when its age cannot be determined in other ways. Unfortunately, lens patterns are typically modified gradually and in piecemeal fashion. The inferred lamp age may thus span a decade or more.

An attempt has been made to reproduce the lens patterns on a 1:1 basis, but deviations are possible since the illustrations are two dimensional representations of three dimensional objects. The illustrations should not be used to derive measurements to better than 2 mm, or 5 percent of any dimension, whichever is larger.

Some of figures A1 through A74 represent lenses that were never incorporated into headlights (e.g., note the lenses with large outer flange, such as A2). The remaining lenses pictured (such as lens #164, figure A1) were removed from assembled headlamps.

TABLE A1. Data for lenses shown in appendix A

Figure	Lamp Maker	Glass Maker	Lamp Brand	Beam ^a Type	Lens Pattern ^b			Fluting ^c Width	Comments
					Phased In	Phased Out	Phased Out		
A1	GE	GE	GE	H	≤6-65		.25"		
A2	GE	GE	GE	H	11-67	1-72	.25		
A3	GE	GE	GE	H	8-71	≥1-73	.125		
A4	GE	GE	GE	H	≤11-72		.125		
A5	GE	GE	GE	L	≤11-67	3-73	.25		
A6	GE	GE	GE	L	≤5-70		.25		
A7	GE	GE	GE	L	8-71	≥5-74	.125		
A8	GE	GE	GE	L	≤72		.125		
A9	GE	GE	GE	L	≤3-73	≥5-73	.125	Canadian GE similar patterns	
A10	GE	GE	GE	L	≤58?		.25	Canadian GE similar patterns	
A11	GE	GE	GE	T	≥56	≤58	.25	Canadian GE	
A12	GE	GE	GE	T	≥68	≤73	.25	Canadian GE	
A13	GE	GE	GE	T	≥68	≤72	.25	Canadian GE	
A14	GE	GE	GE	T	~64?		.25	Popular lamp	
A15	GE	GE	GE	T	≤2-73	≥3-71	.25		
A16	GE	GE	GE	T	≤3-67		.25		
A17	GE	GE	GE	T	≤62	≥5-74	.25		
A18	GE	GE	GE	T	8-71		.125		
A19	GE	GE	GE	T	≤7-73		.125		
A20	Guide	Anchor H.	Guide	H	≤2-71		.25		
A21	Guide	Anchor H.	Guide	H	≤8-71	≥9-71	.25	"Power Beam"	
A22	Guide	Corning	Guide	H	5-72	Cur.	.25		
A23	Guide	Corning	Guide	H	5-62	5-68	.25		
A24	Guide	Corning/AH	Guide	L	5-62		.25		
A25	Guide	Corning	Guide	L	≤2-71		.25		
A26	Guide	Corning	Guide	L	≤11-70	≥8-71	.25		
A27	Guide	Corning	Guide	L	≤1-73	Cur.	.25	With/Without "USA"	
A28	Guide	Corning	Guide	T	8-68	7-72	.25	Similar fluting patterns but	
A29	Guide	Corning	Guide	T	7-69	≥4-74	.25	complementary views	
A30	Tung-Sol	Corning	Tung-Sol	T	7-69	4-74	.25	Also exists with "FoMoCo" logo	
A31	Tung-Sol	Corning	Tung-Sol	H	≤12-67	Cur.	.125		
A32	Tung-Sol	Corning	Tung-Sol	H	72		.125	"T-S" monogram absent	
A33	Tung-Sol	Corning	Tung-Sol	H	7-70	≥5-74	.125		
A34	Tung-Sol	Corning	Tung-Sol	H	9-71	≥5-74	.125		
A35	Tung-Sol	Corning	Tung-Sol	L	1-1-56	≥5-74	.25		
A36	Tung-Sol	Corning	Tung-Sol	L	≤4-64		.25		
A37	Tung-Sol	Corning	Tung-Sol	L	3-64	1-67	.25	Similar to A34 but has "T-S"	
A38	Tung-Sol	Corning	Tung-Sol	L	6-66	1-1-74	.25	monogram; same patterns but one has "FoMoCo" logo	

TABLE A1. Data for lenses shown in appendix A—Continued

A39	West.	Anchor H.	L	5-70	4-71	.125	Similar patterns but change in fluting width
A40	West.	Corning	L	≤3-73	Cur.	.125	
A41	West.	Corning	T	1-67	≥4-74	.25	
A42	West.	Corning	T	3-1-70	5-74	.125	
A43	West.	Corning	T	≤8-73	Cur.	.125	
A44	West.	Anchor H.	H	≤4-70	Cur.	.25	
A45	West.	Corning	H	5-67	≥72	.125	
A46	West.	Corning	H	12-63	10-72	.25	
A47	West.	Corning	L	3-65	≤10-71	.25	
A48	West.	Corning	L	3-65	Cur.	.125	
A49	West.	Corning	L	3-65	Cur.	.25	
A50	West.	Corning	L	6-64	4-73	.25	
A51	West.	Corning	T	3-61	Cur.	.25	
A52	West.	Corning	T	12-63	Cur.	.125	
A53	West.	Corn./A.H.	T				Similar to A52 but no Ford logo Similar to A53 but has 1/8" flutes
A54	West.	Corn./A.H.	T				
A55	Tung-Sol	Corning	H	≤2-66	≥2-72	.125	
A56	Tung-Sol	Corning	H	≤9-69	Cur.	.125	
A57	Tung-Sol	Corning	L	1-63	5-68	.125	
A58	Tung-Sol	Corning	L	≤1-70	3-73	.125	
A59	Tung-Sol	Corning	L	12-66	Cur.	.125	
A60	Tung-Sol	Corning	T	5-73		.125	
A61	GE	GE	H	≤7-68		.125	
A62	GE	GE	L			.125	
A63	GE	GE	L			.125	
A64	GE	GE	T			.125	
A65	Lucas	Lucas	T			.25	
A66	Lucas	Lucas	T			.25	
A67	Koito	Iwaki	H	4-72	Cur.	.25	
A68	Koito	Iwaki	L	10-73	Cur.	.25	
A69	Koito	Iwaki	L			.25	
A70	Koito	Iwaki	T			.125	
A71	Stanley	Iwaki	H	10-73	Cur.	.25	
A72	Stanley	Iwaki	L	10-74	Cur.	.25	
A73	Stanley	Iwaki	L	10-74	Cur.	.125	
A74	Toshiba	Showa	T	10-74	Cur.	.25	

^a "H" = high beam, "L" = low beam, and "T" = twin beam lamp.

^b "Cur." means this pattern still in production as of November 1974.

^c Minimum spacing, in inches, between vertical flutes.

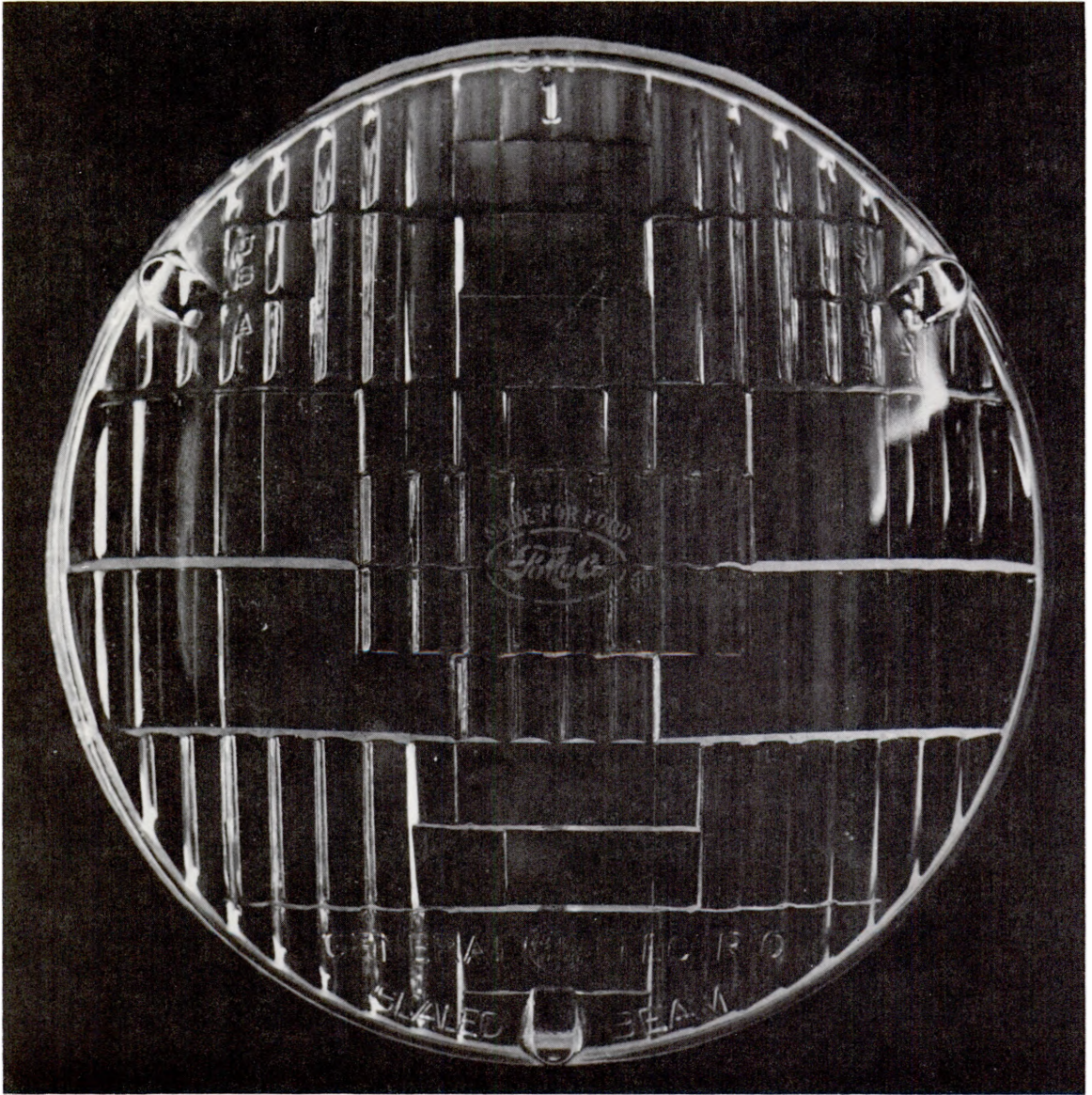

FIGURE A1. *GE, Type 1, for Ford Vehicles.*

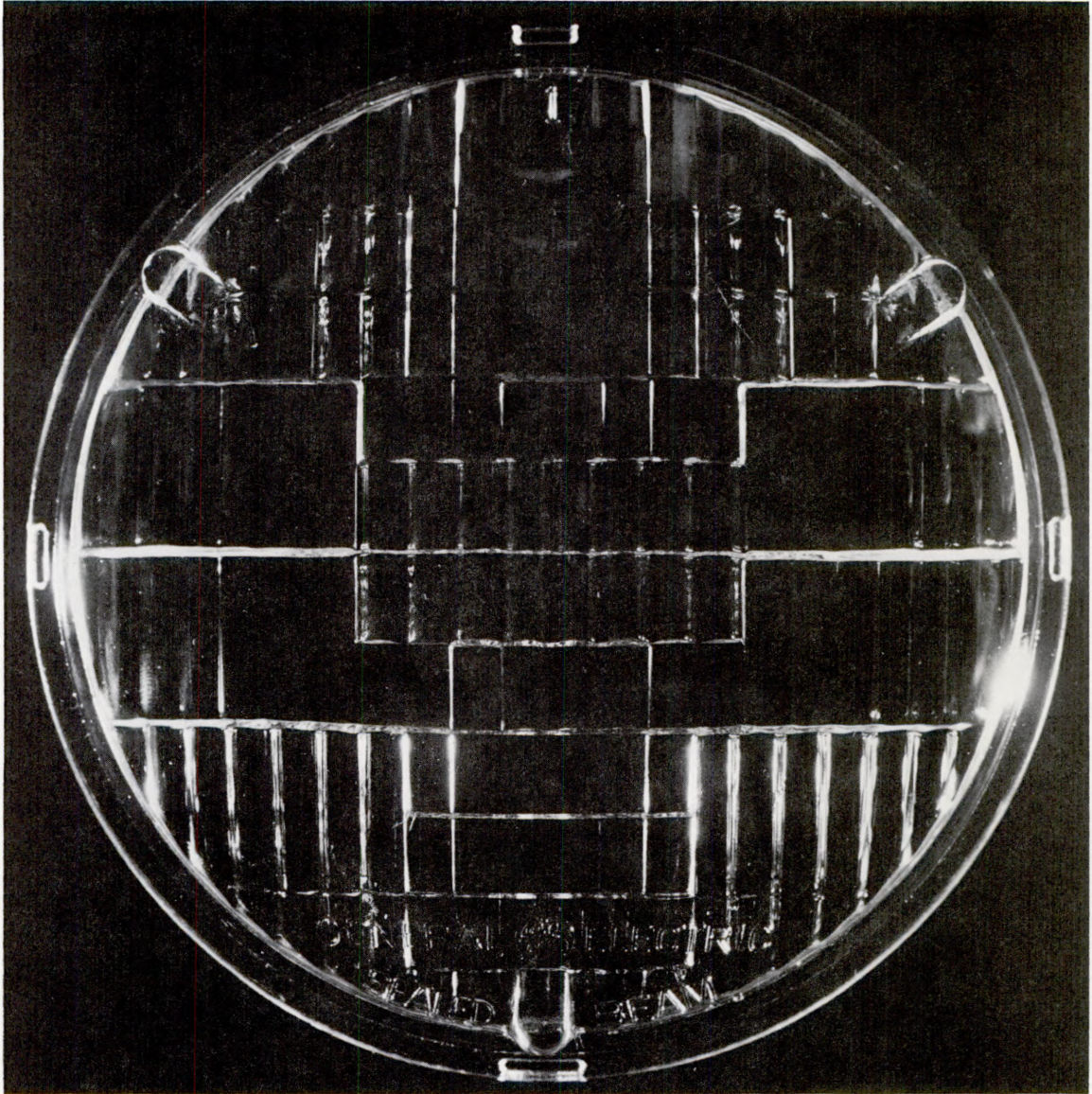

FIGURE A2. *GE, Type 1.*

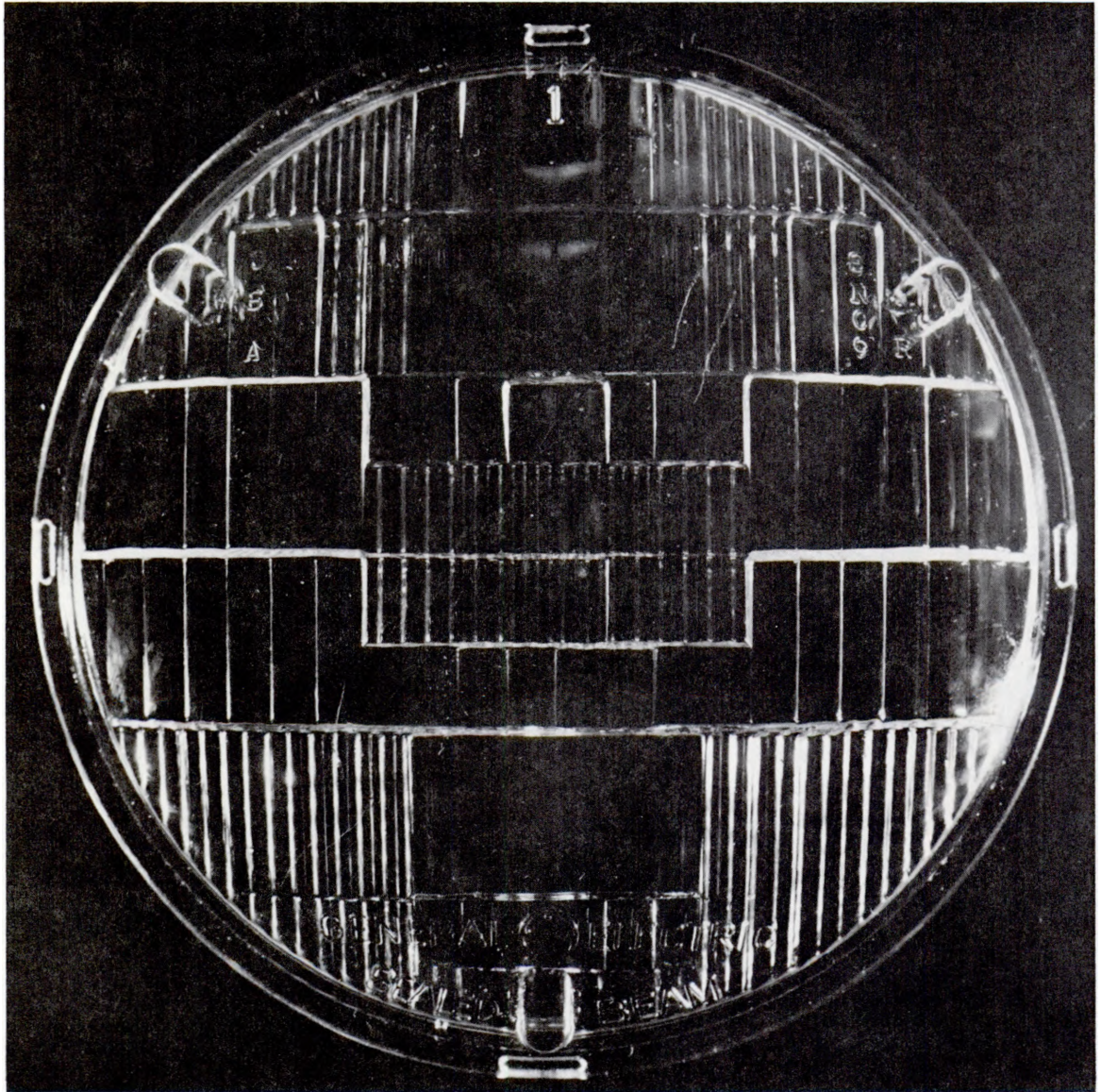

FIGURE A3. *GE, Type 1.*

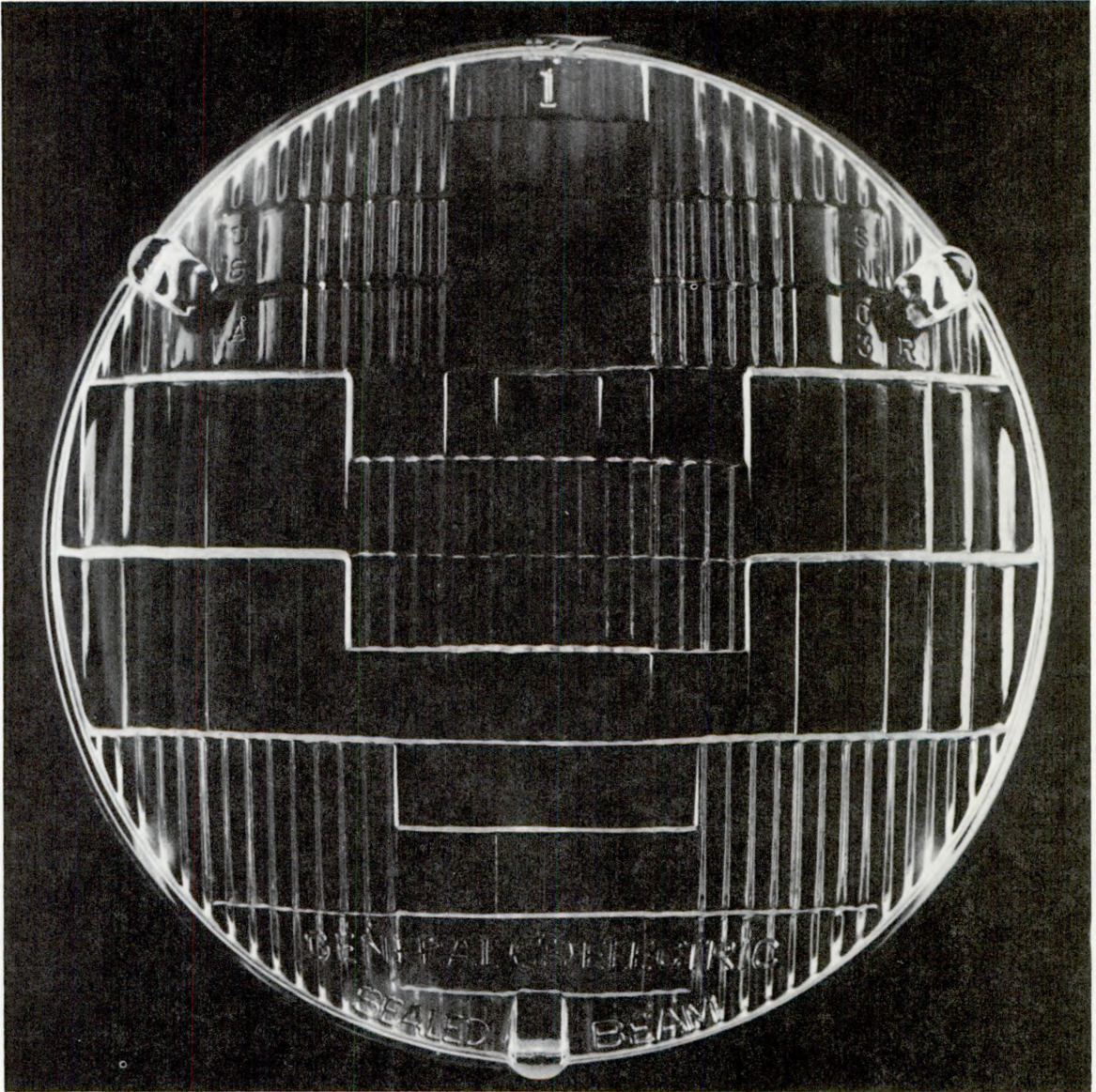

FIGURE A4. *GE, Type 1.*

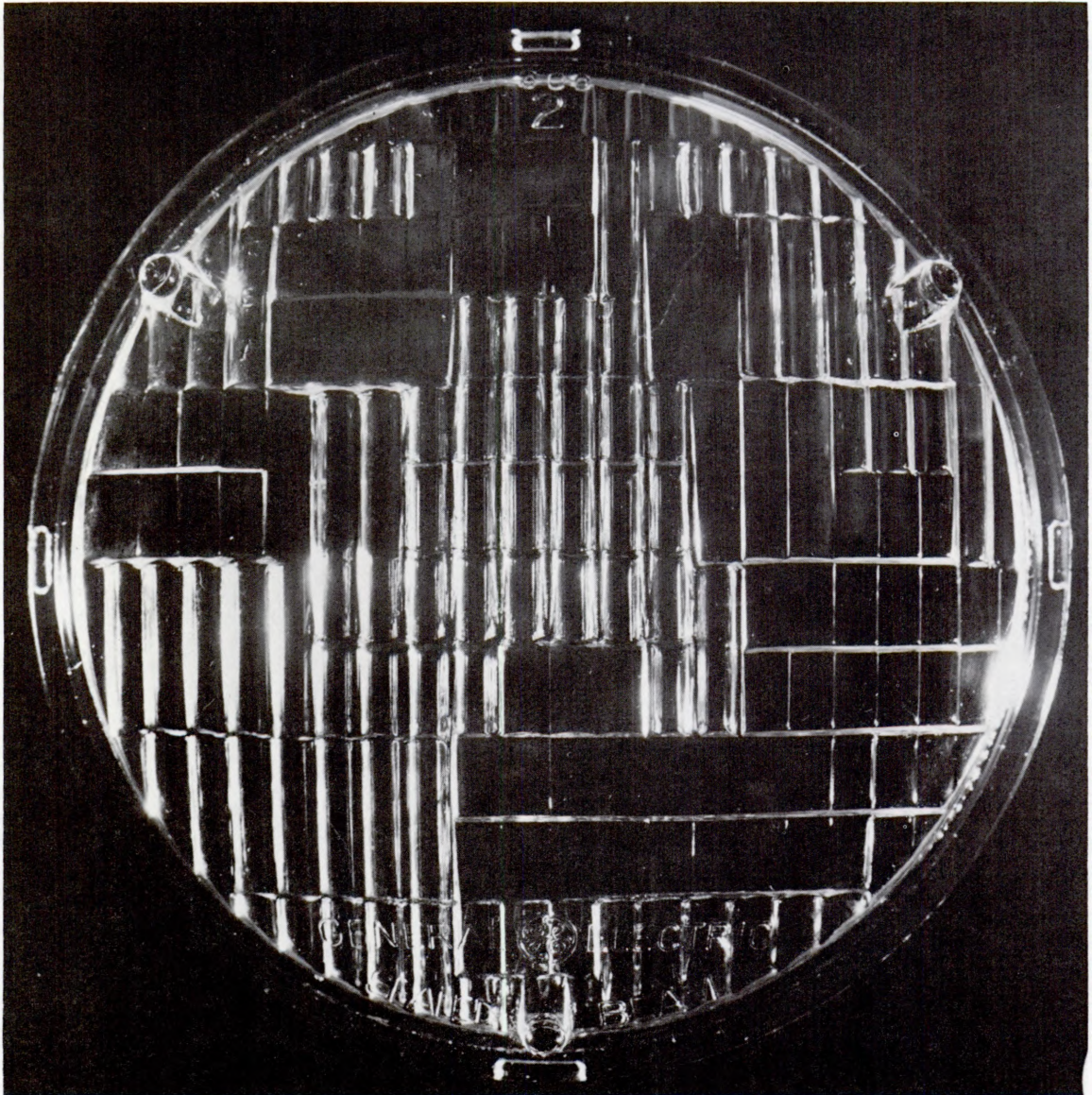

FIGURE A5. GE, Type 2.

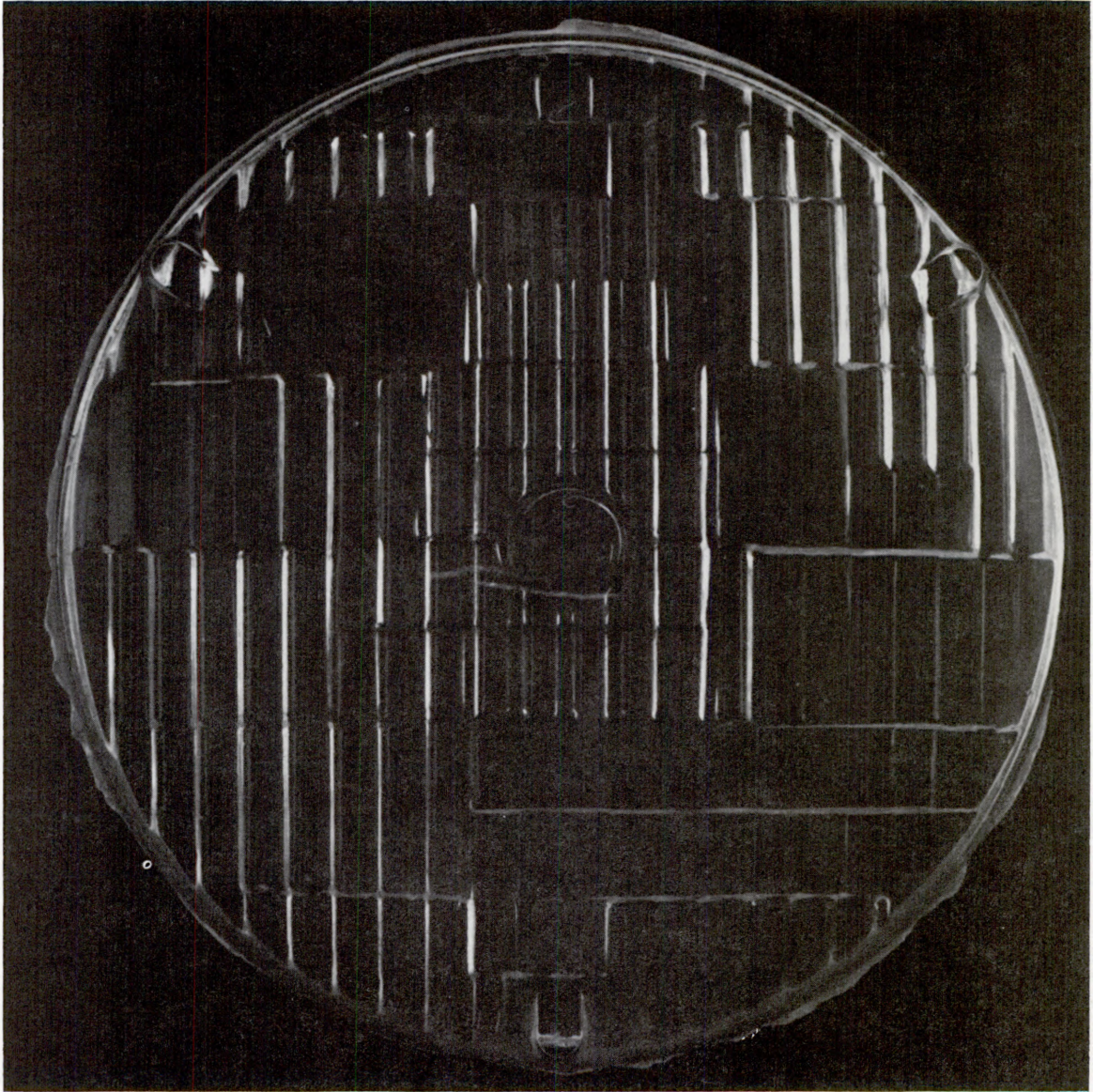

FIGURE A6. *GE, Type 2.*

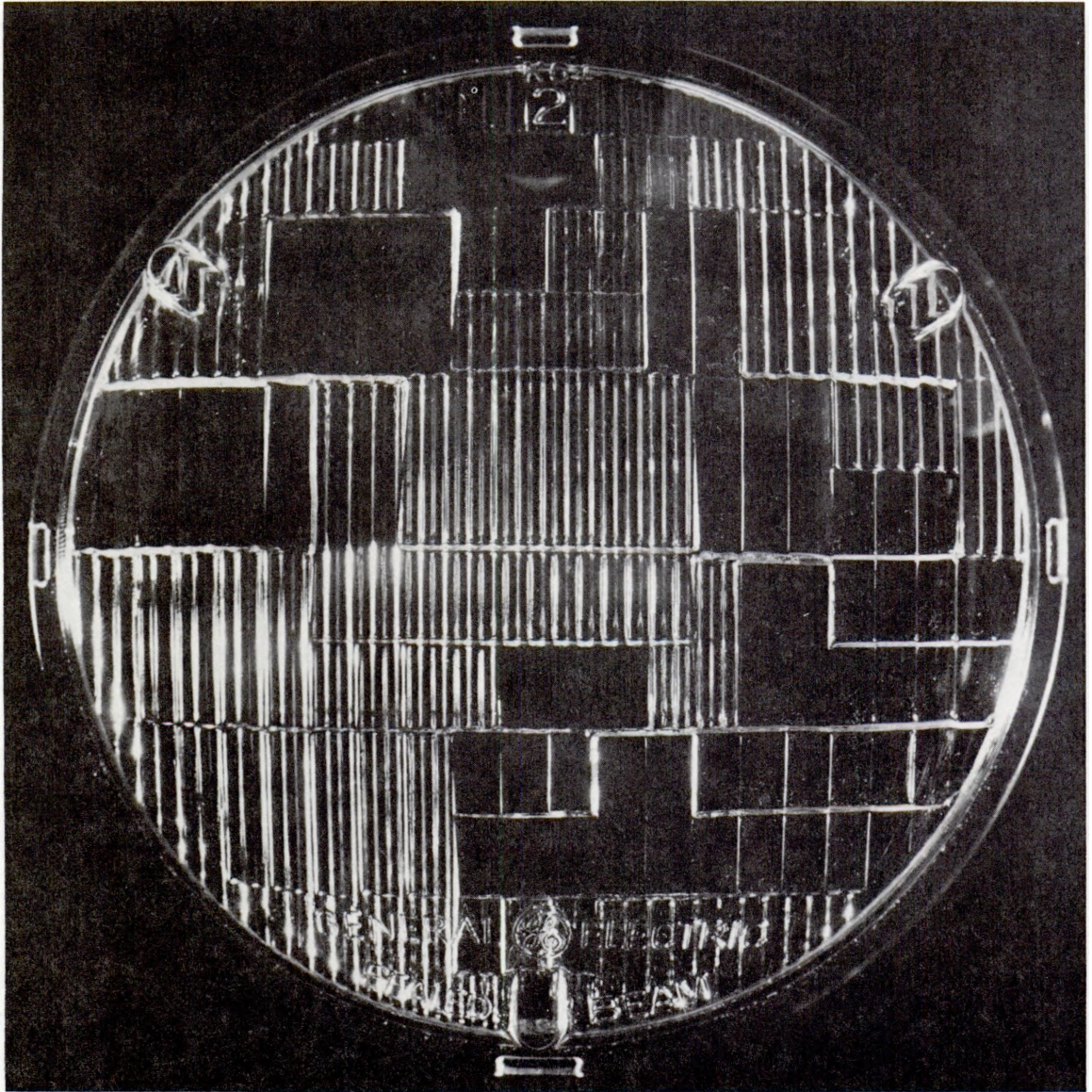

FIGURE A7. GE, Type 2.

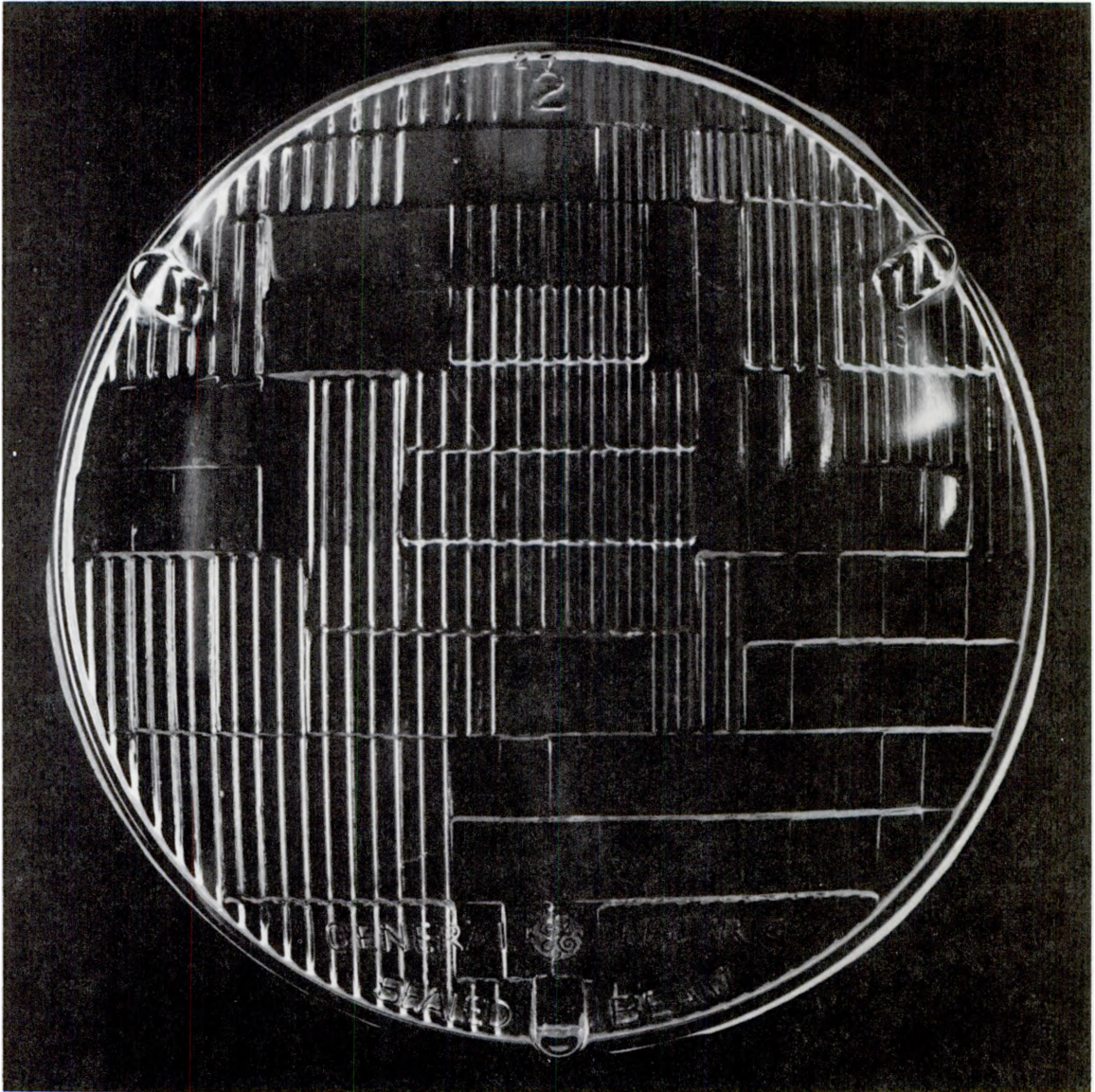

FIGURE A8. GE, Type 2.

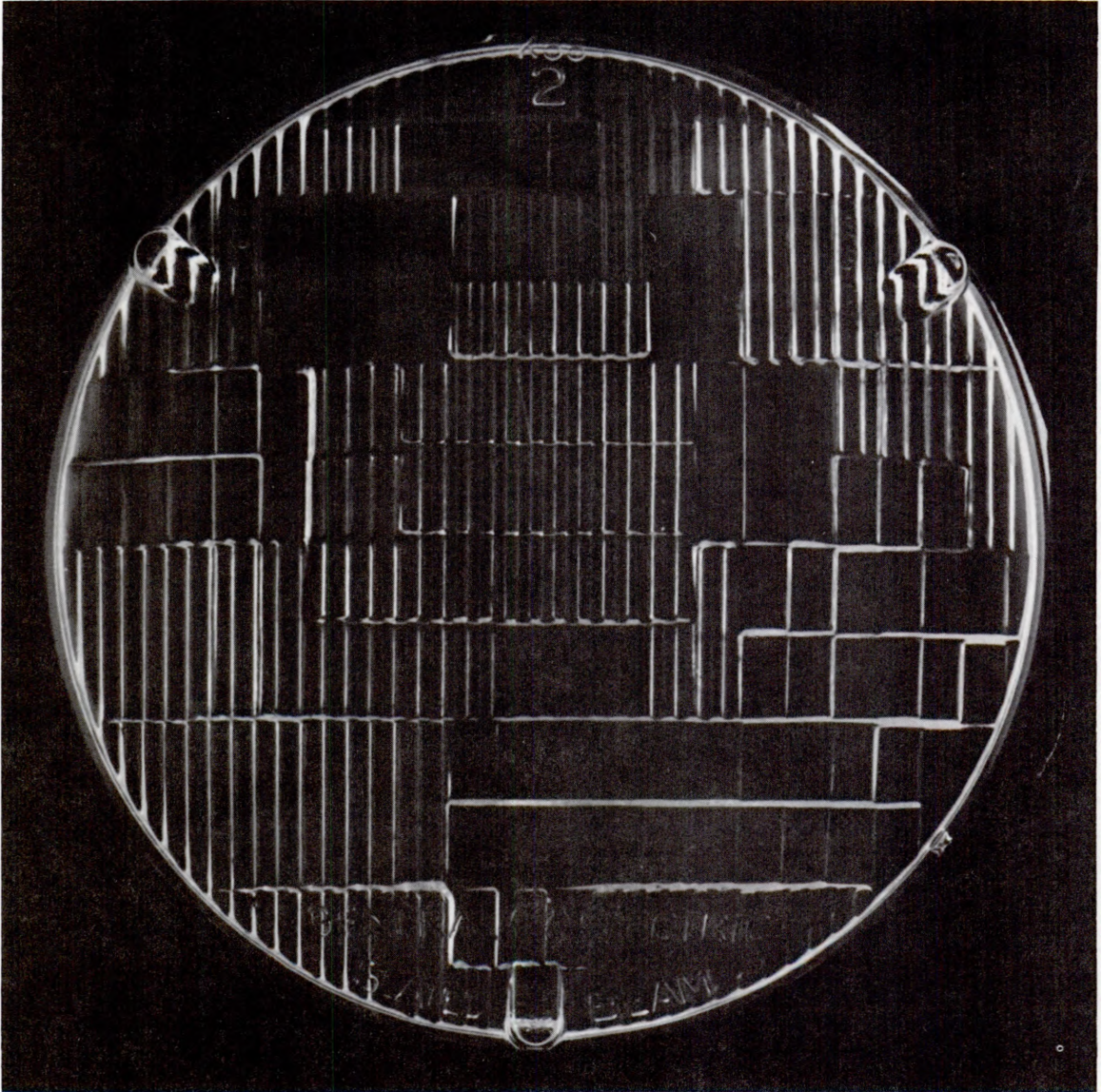

FIGURE A9. *GE, Type 2.*

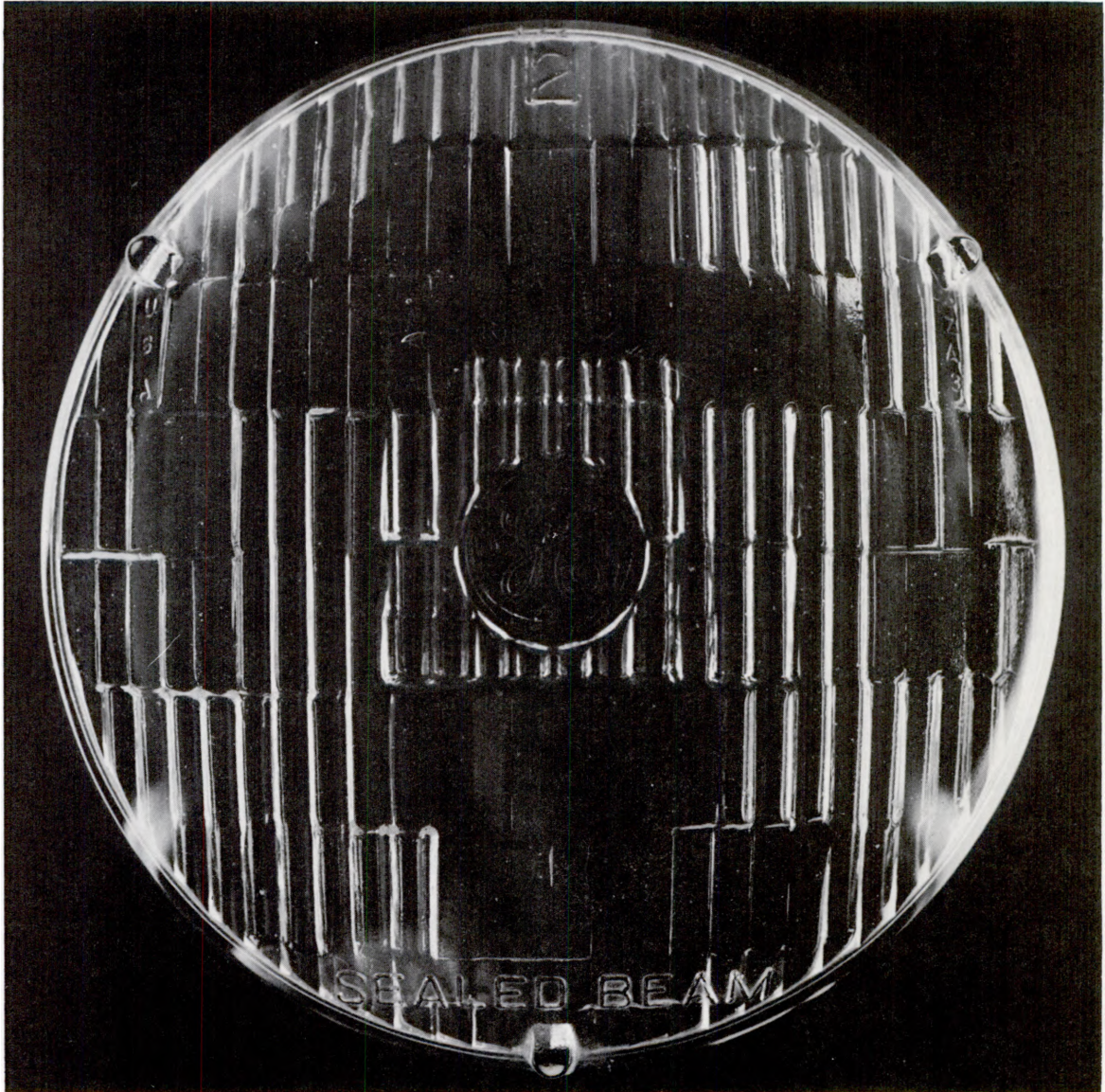

FIGURE A10. *GE, Type 2, Twin-Beam.*

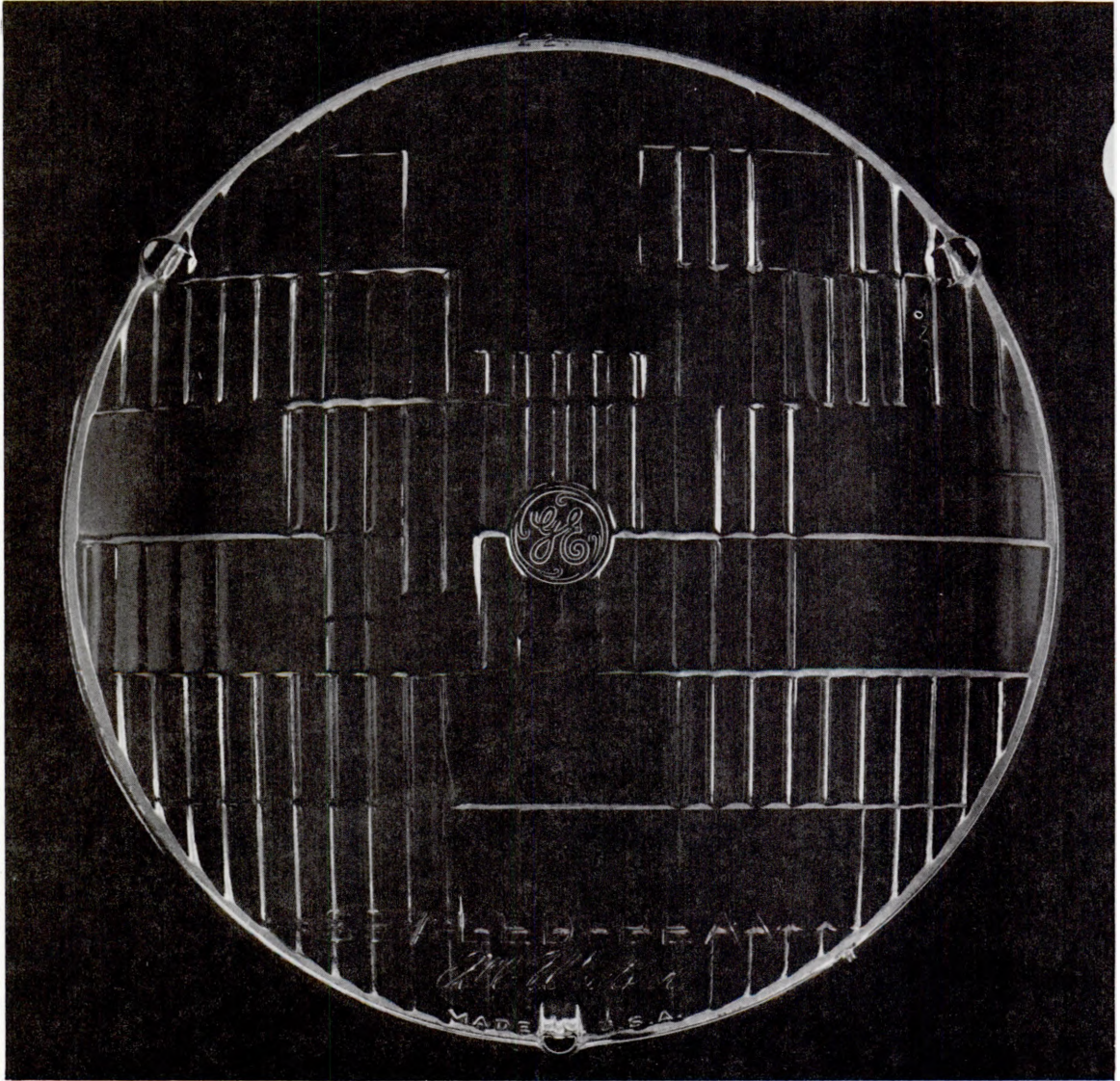

FIGURE A11. *GE, Type 2, Twin-Beam.*

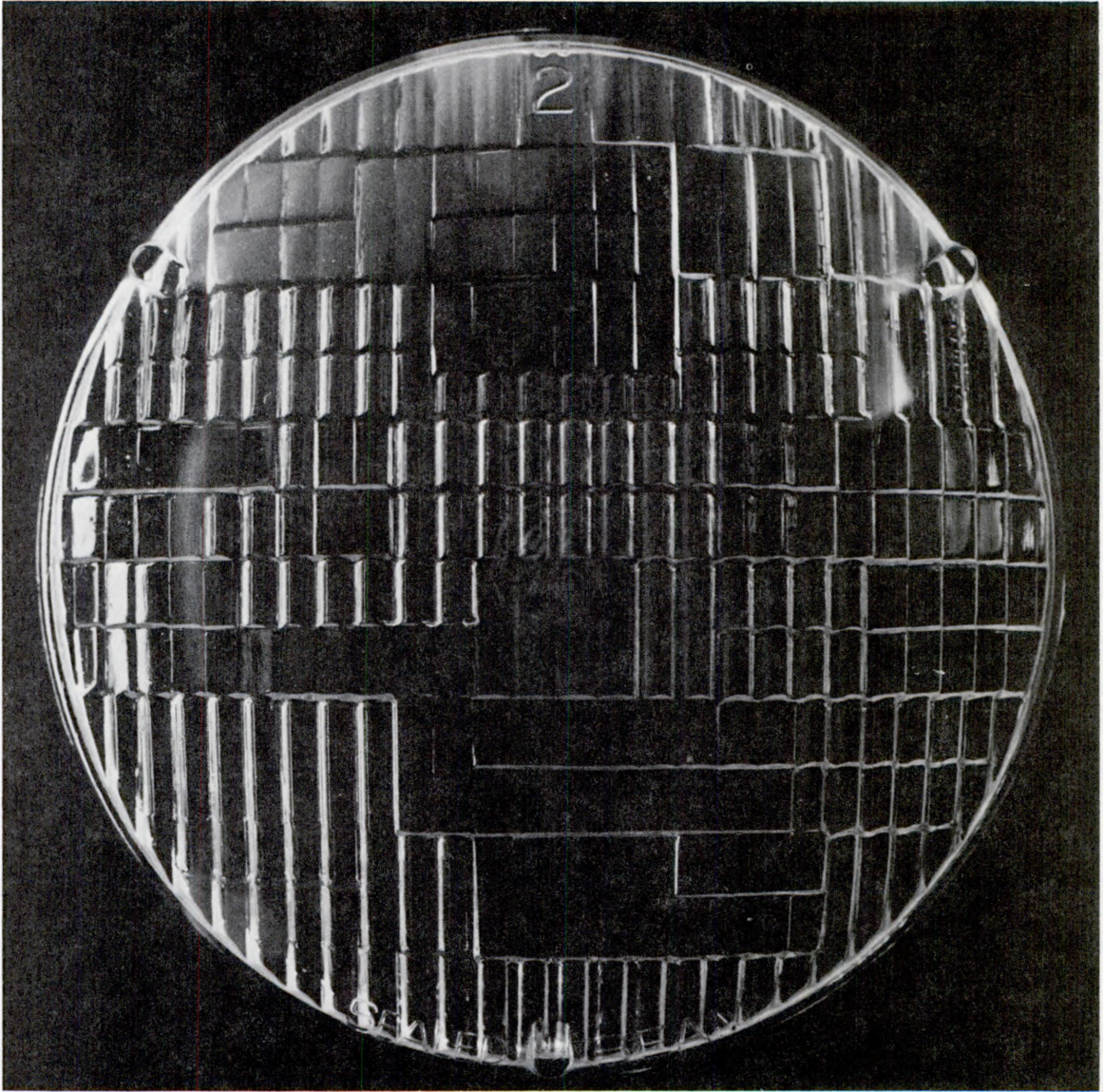

FIGURE A12. *GE, Type 2, Twin-Beam.*

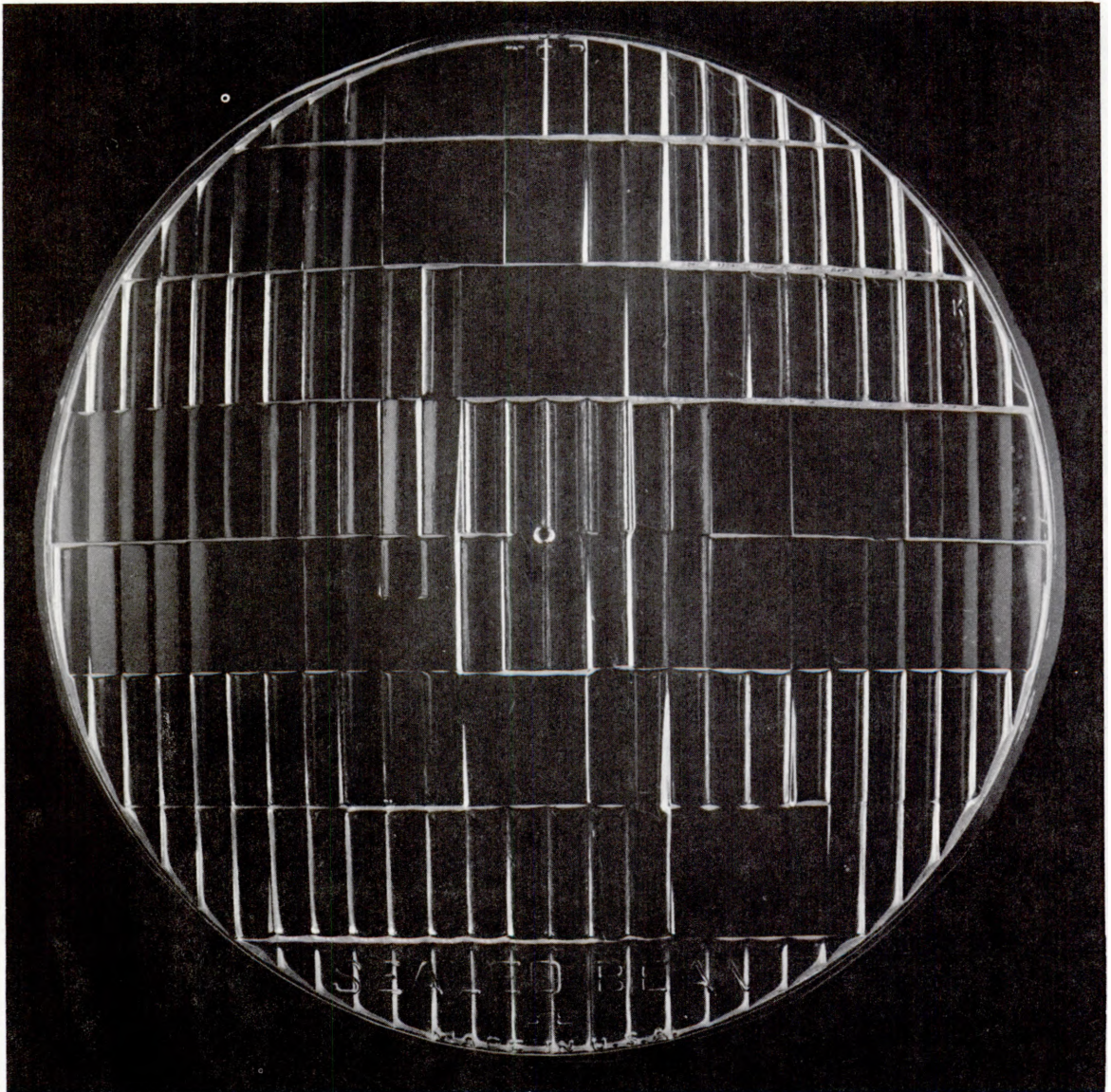

FIGURE A13. *GE, Type 2, Twin-Beam.*

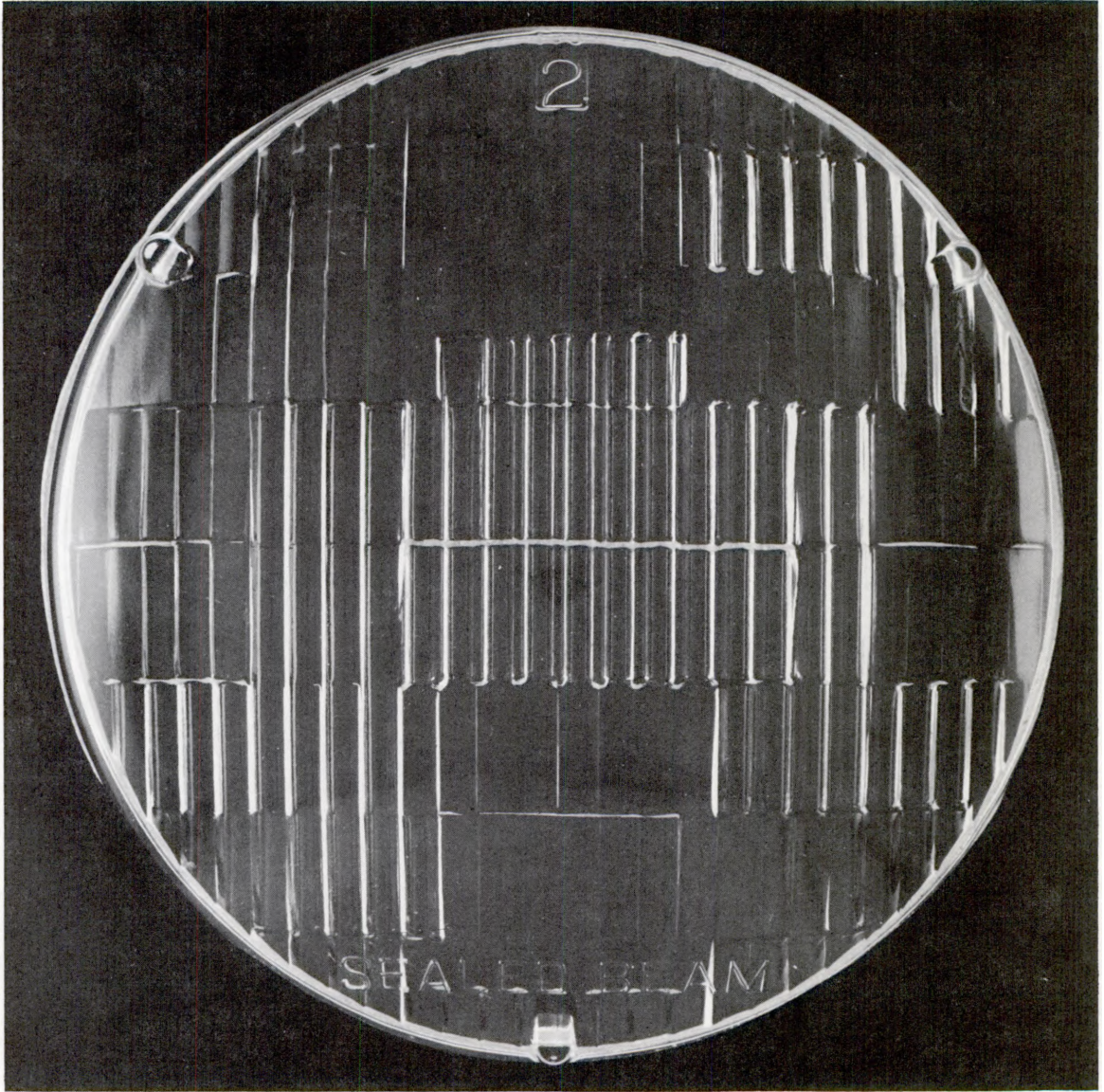

FIGURE A14. GE, Type 2, Twin-Beam.

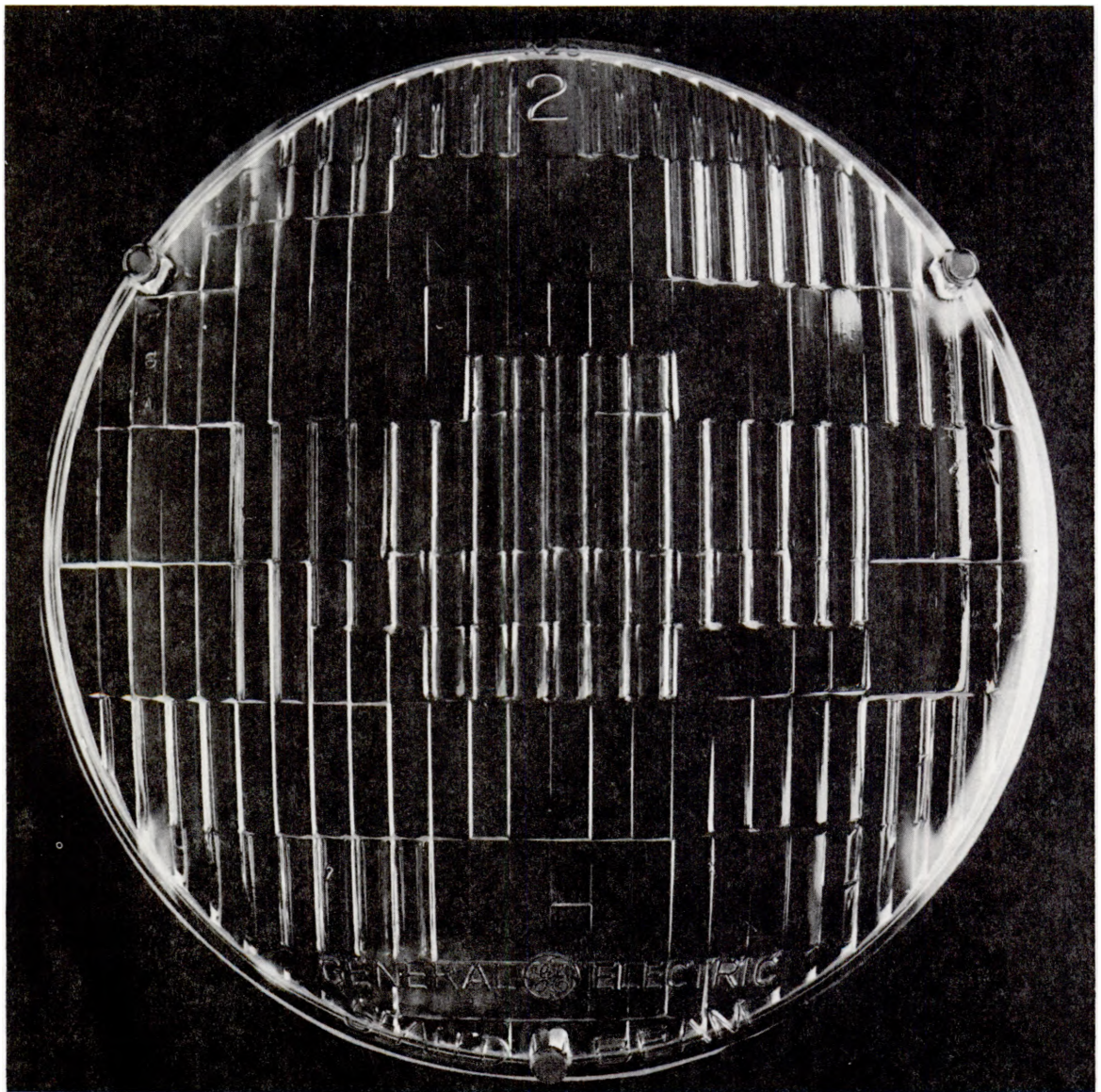

FIGURE A15. *GE, Type 2, Twin-Beam.*

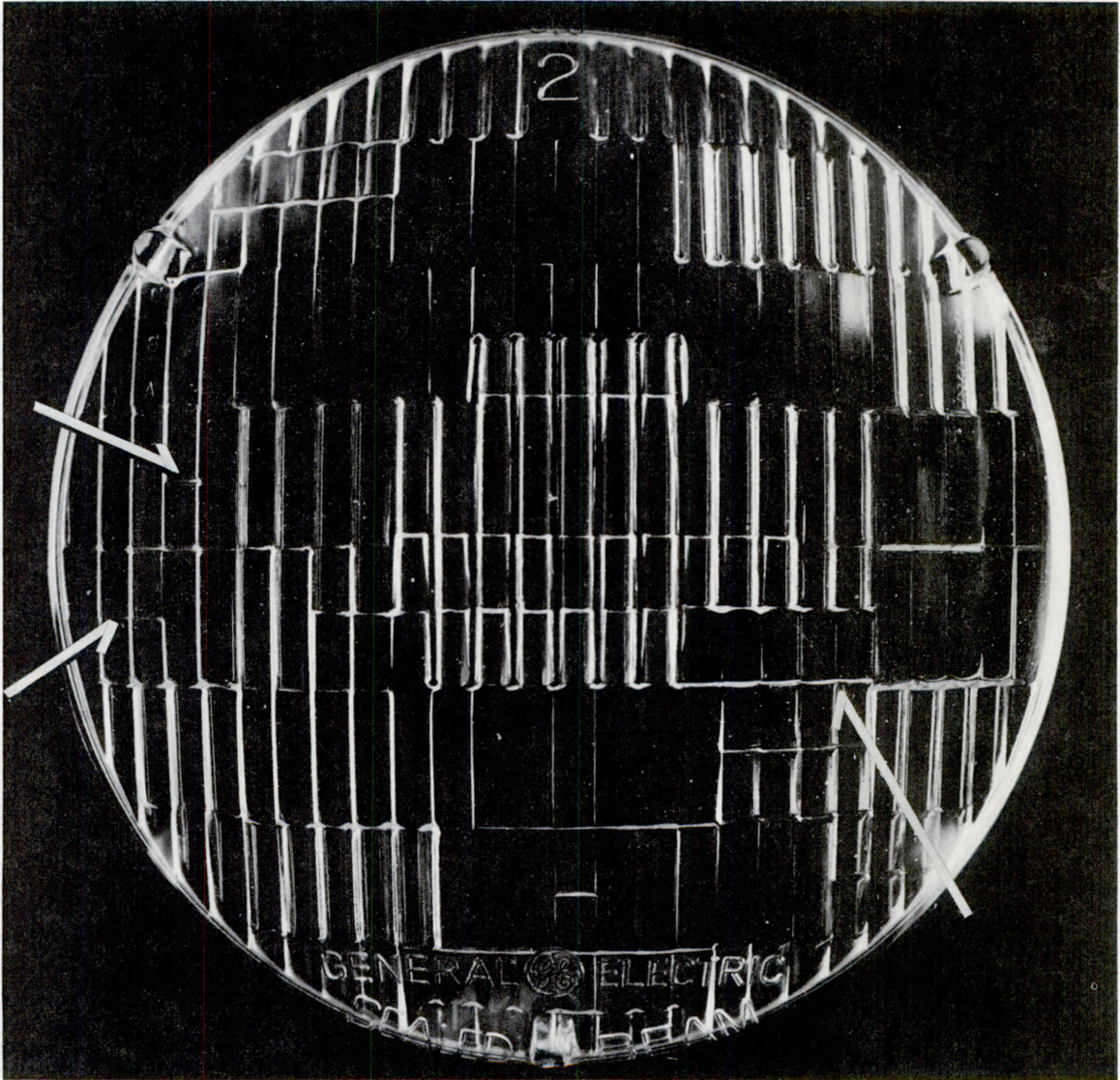

FIGURE A16. GE, Type 2, Twin-Beam.

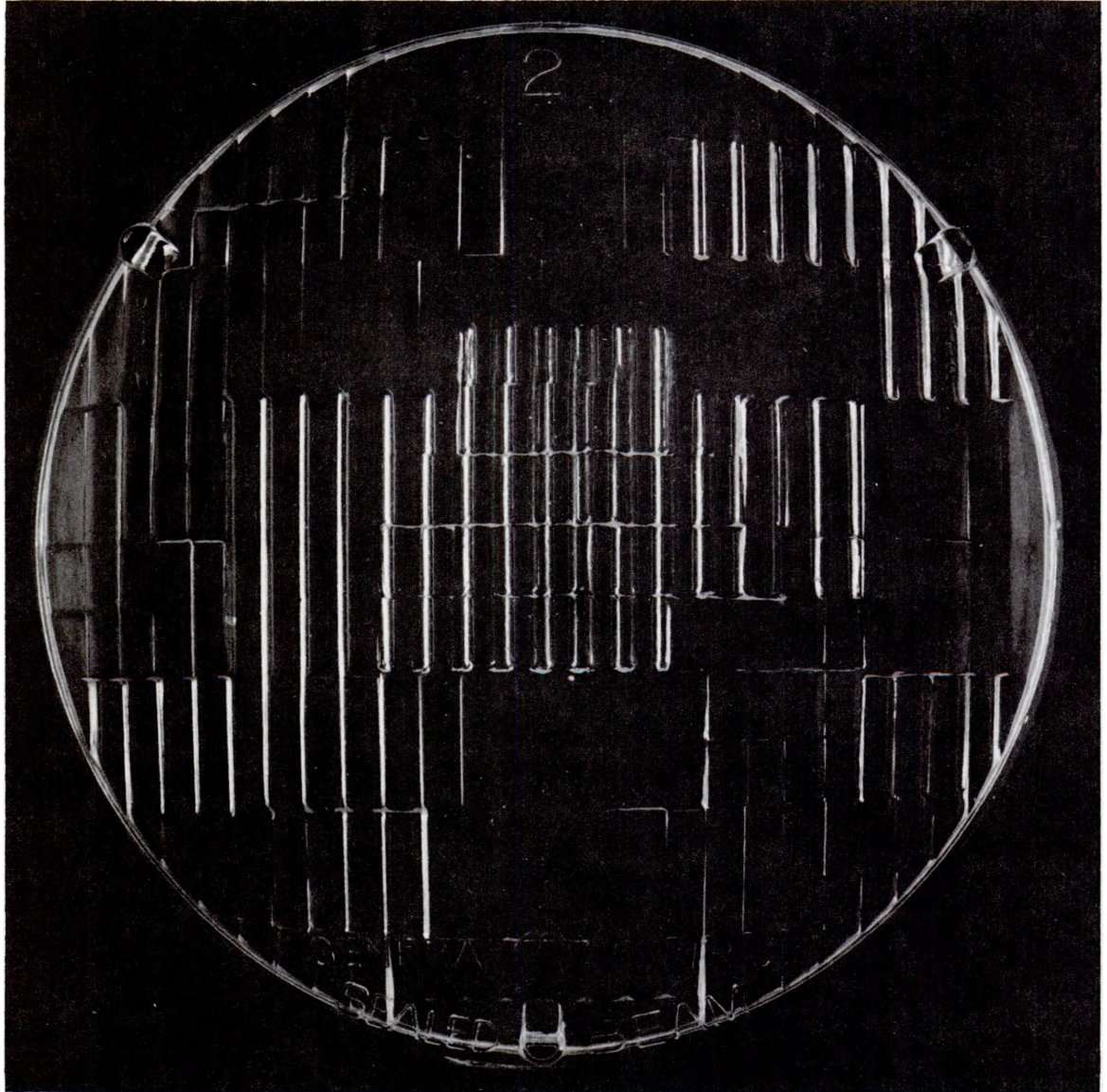

FIGURE A17. *GE, Type 2, Twin-Beam.*

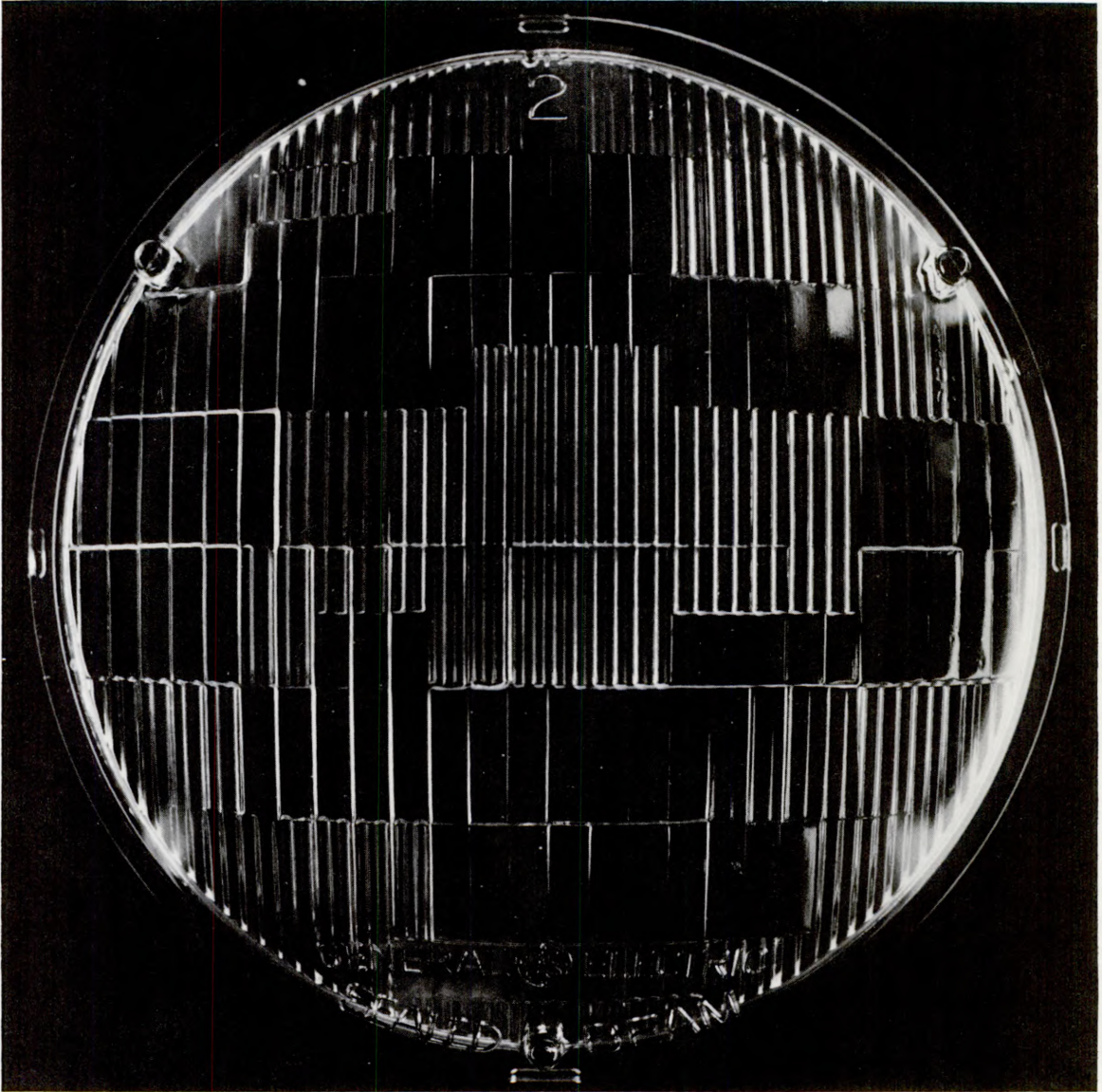

FIGURE A18. *GE, Type 2, Twin-Beam.*

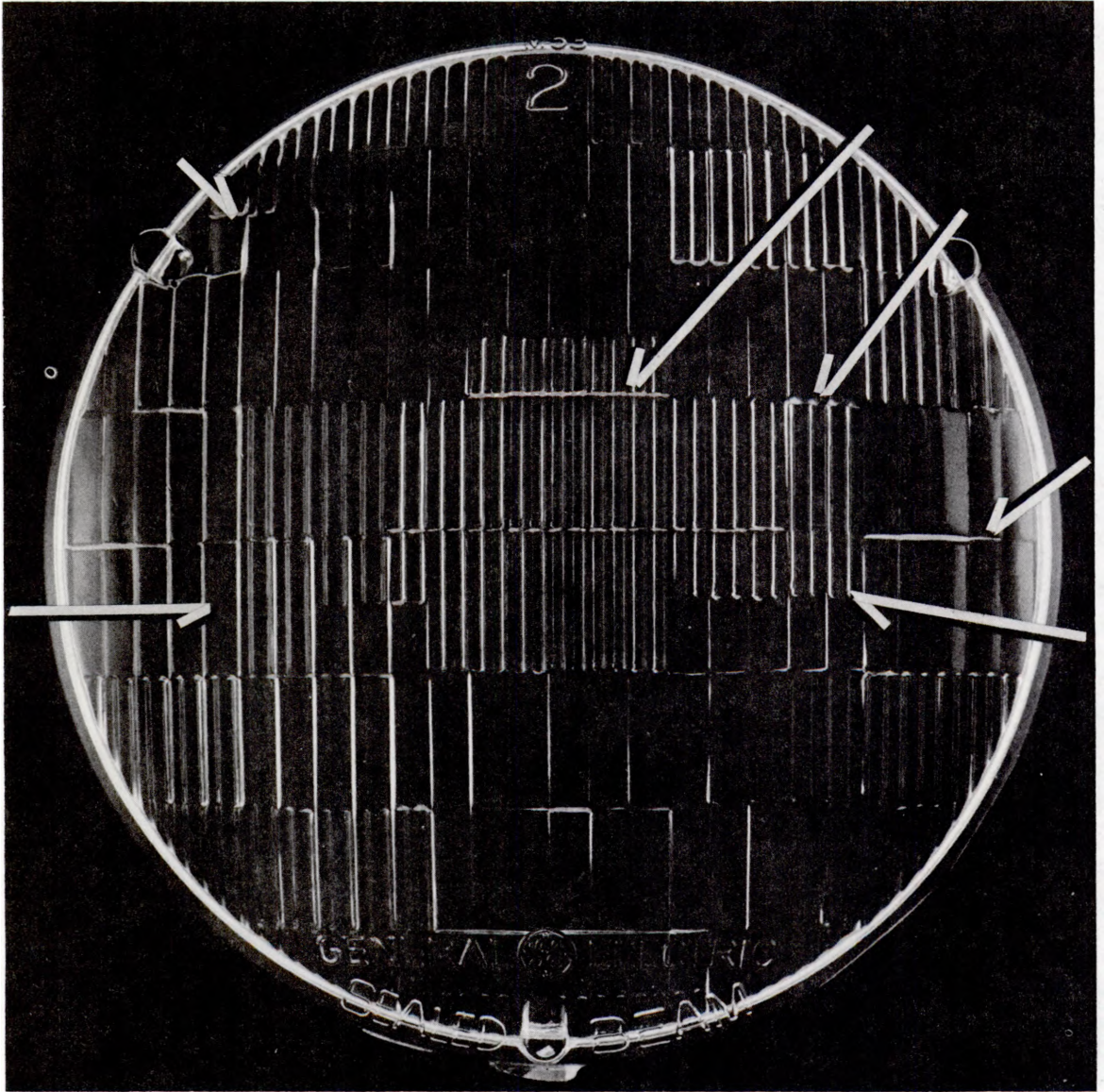

FIGURE A19. GE, Type 2, Twin-Beam.

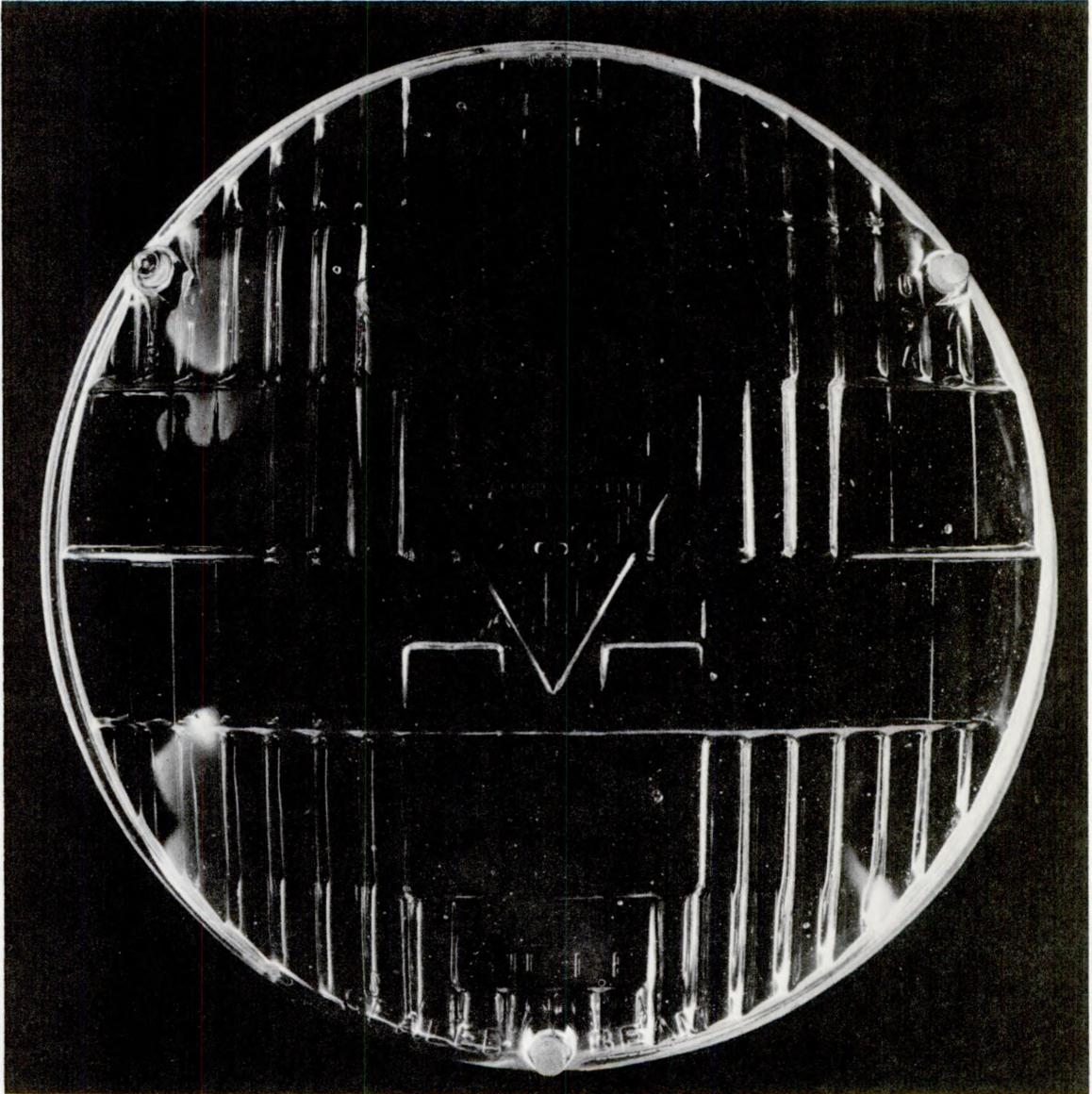

FIGURE A20. *Guide, Type 1.*

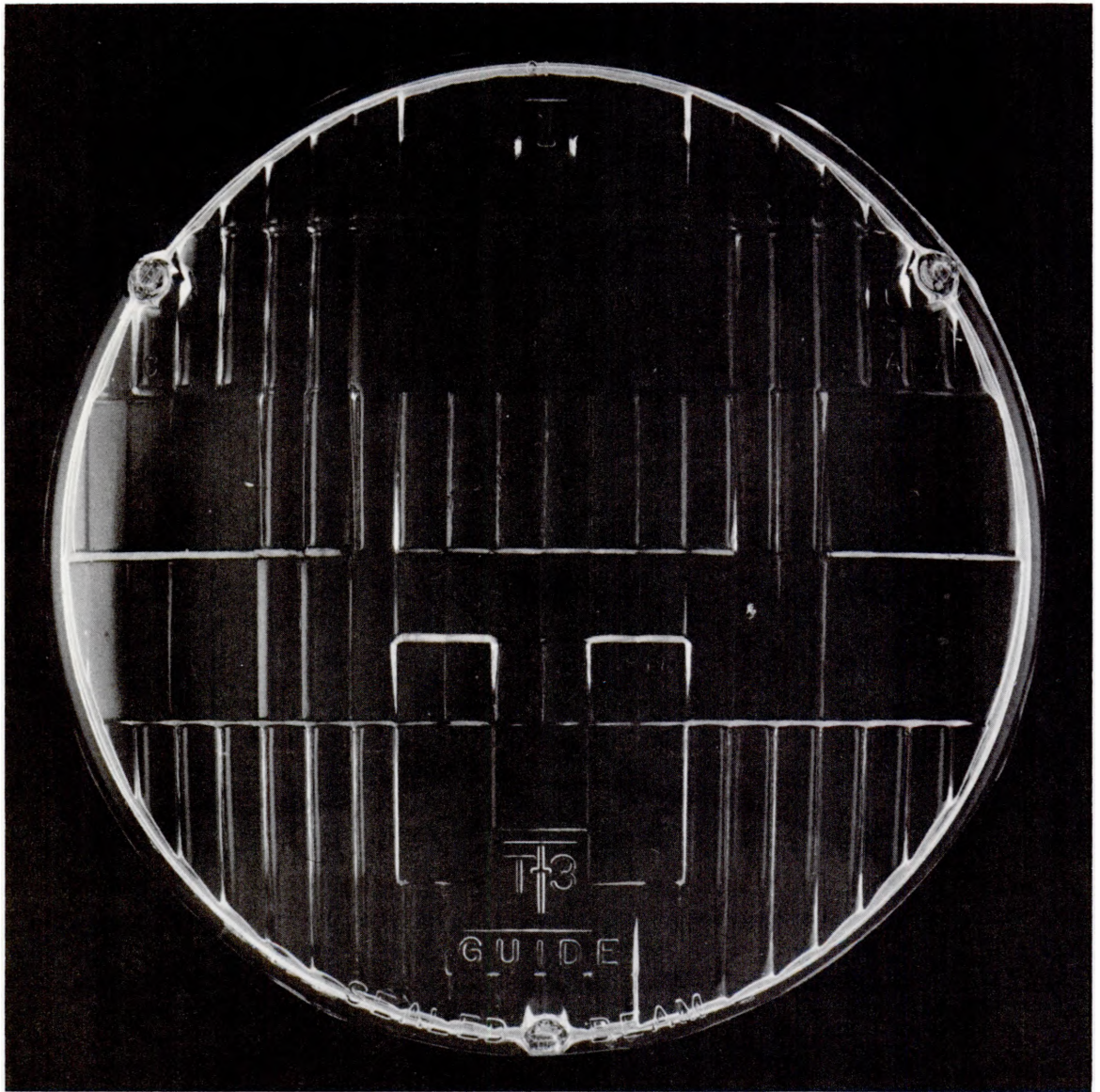

FIGURE A21. *Guide, Type 1.*

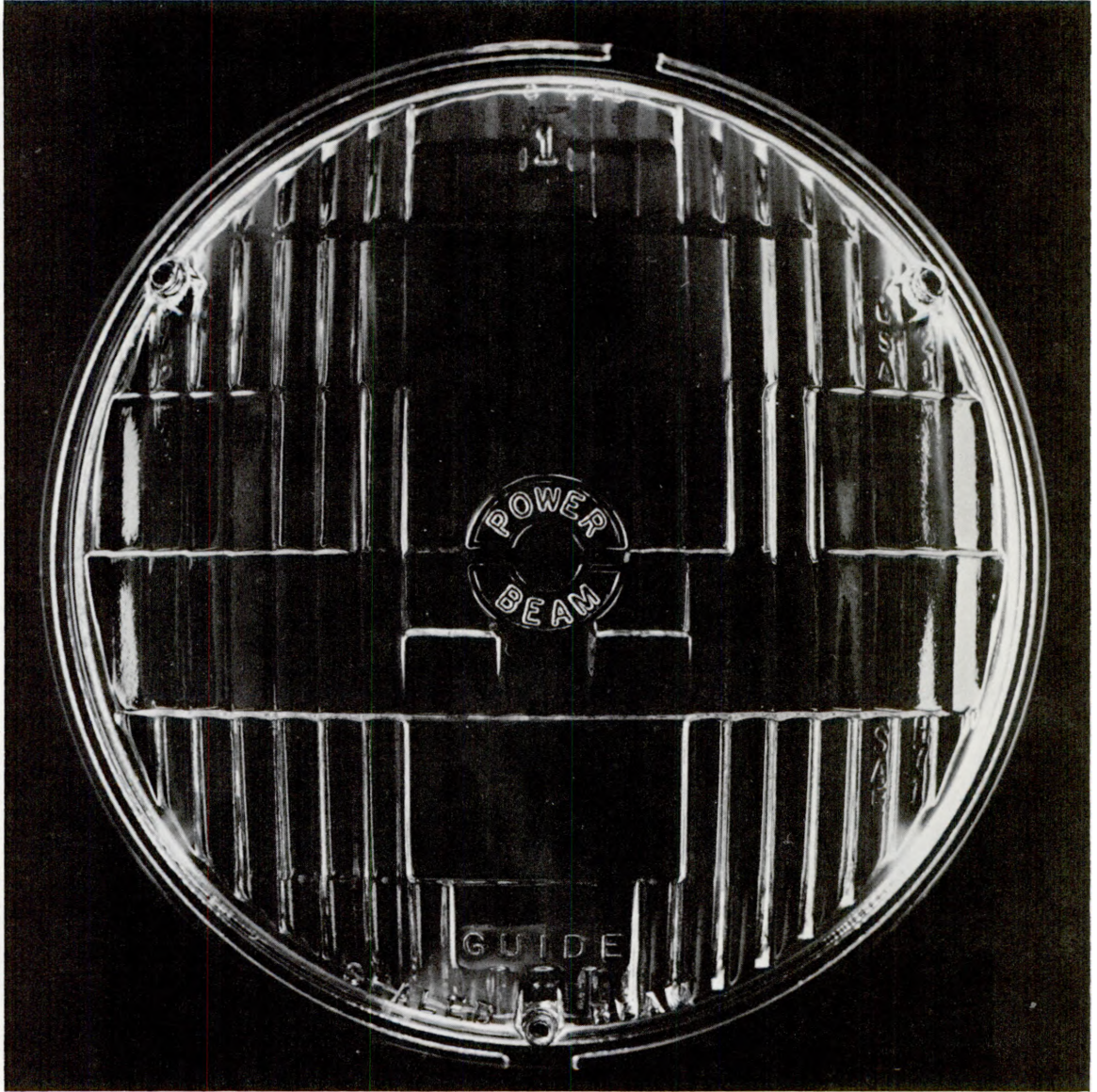

FIGURE A22. *Guide, Type 1.*

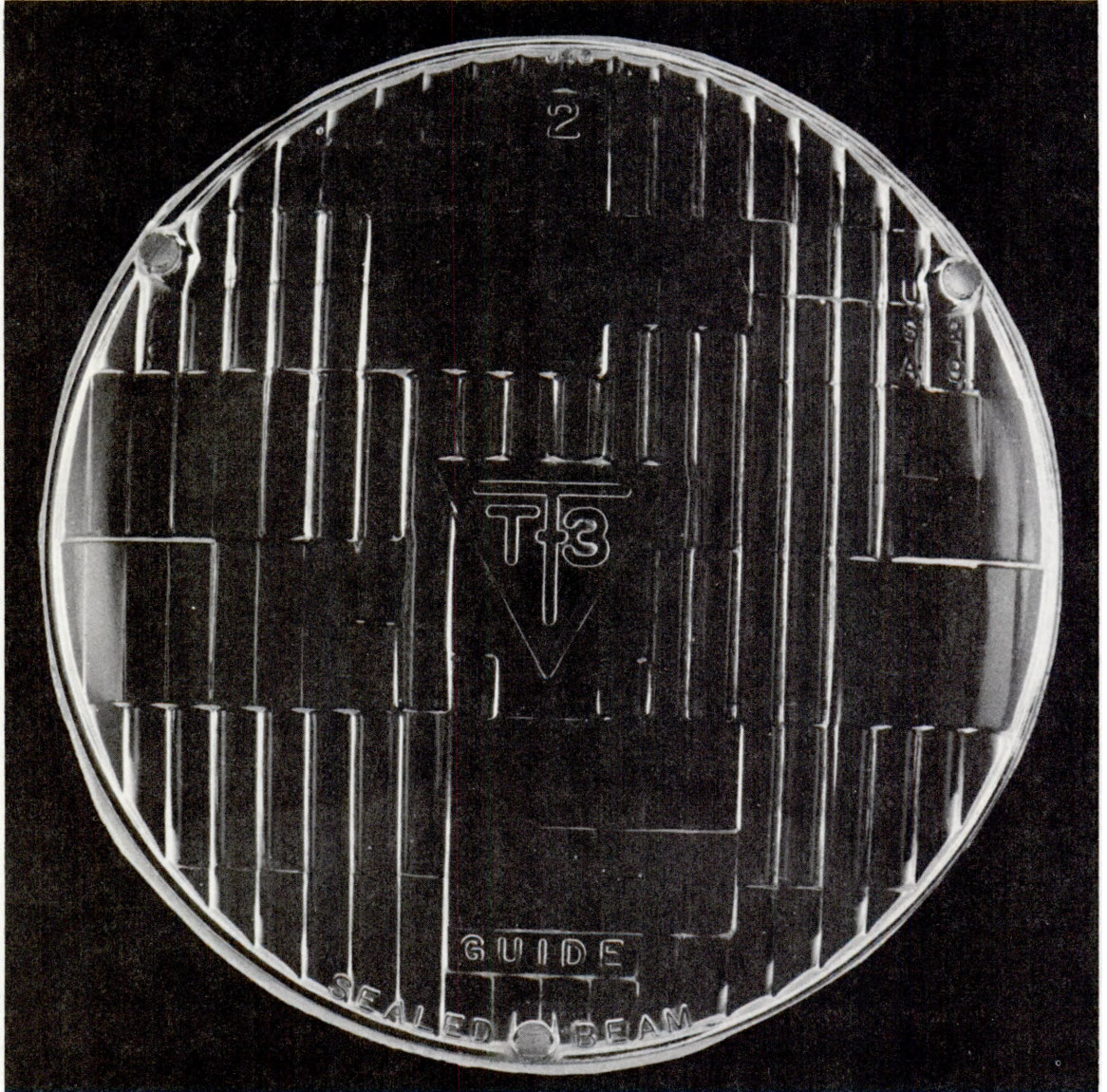

FIGURE A23. *Guide, Type 2.*

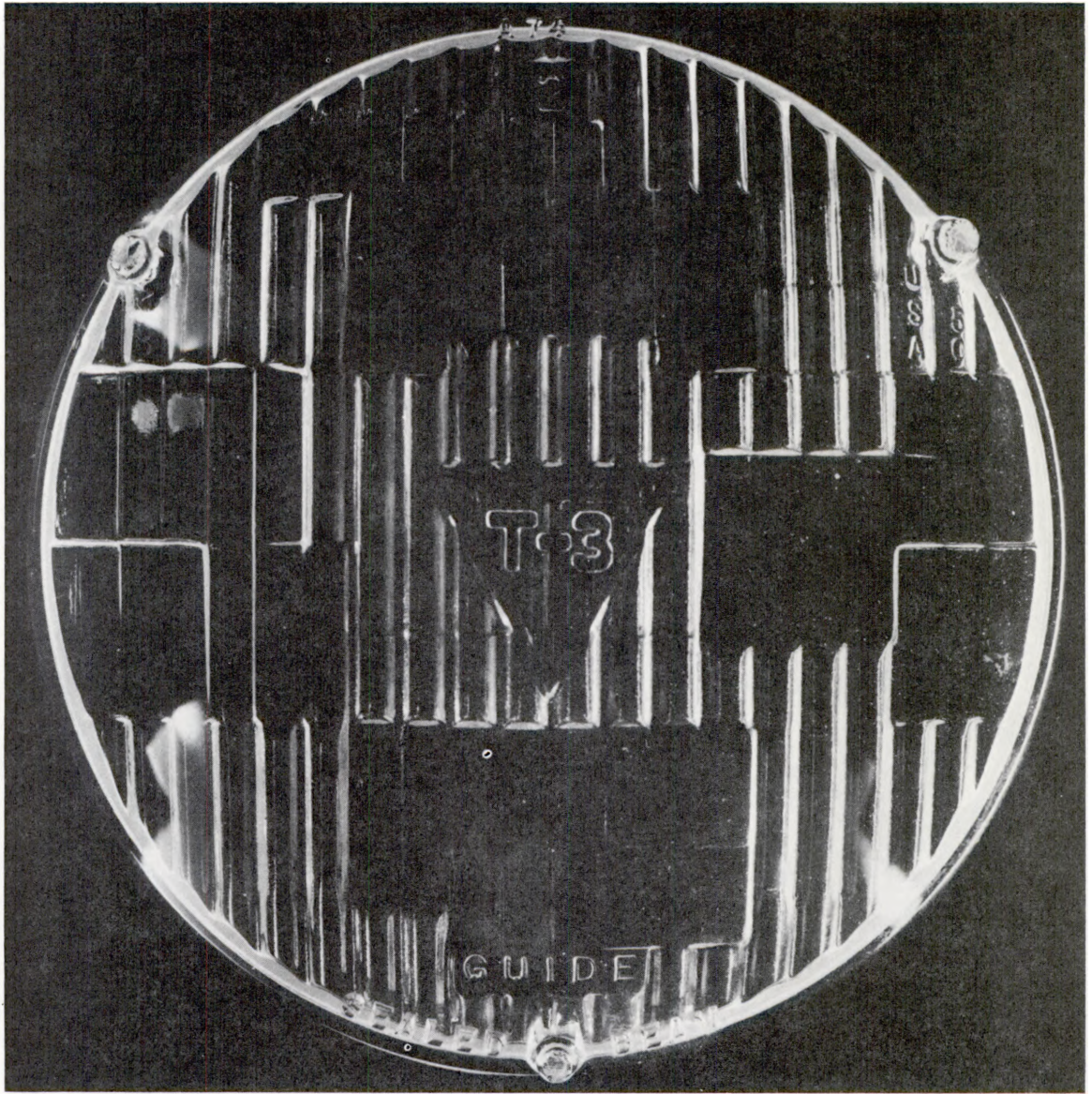

FIGURE A24. *Guide, Type 2.*

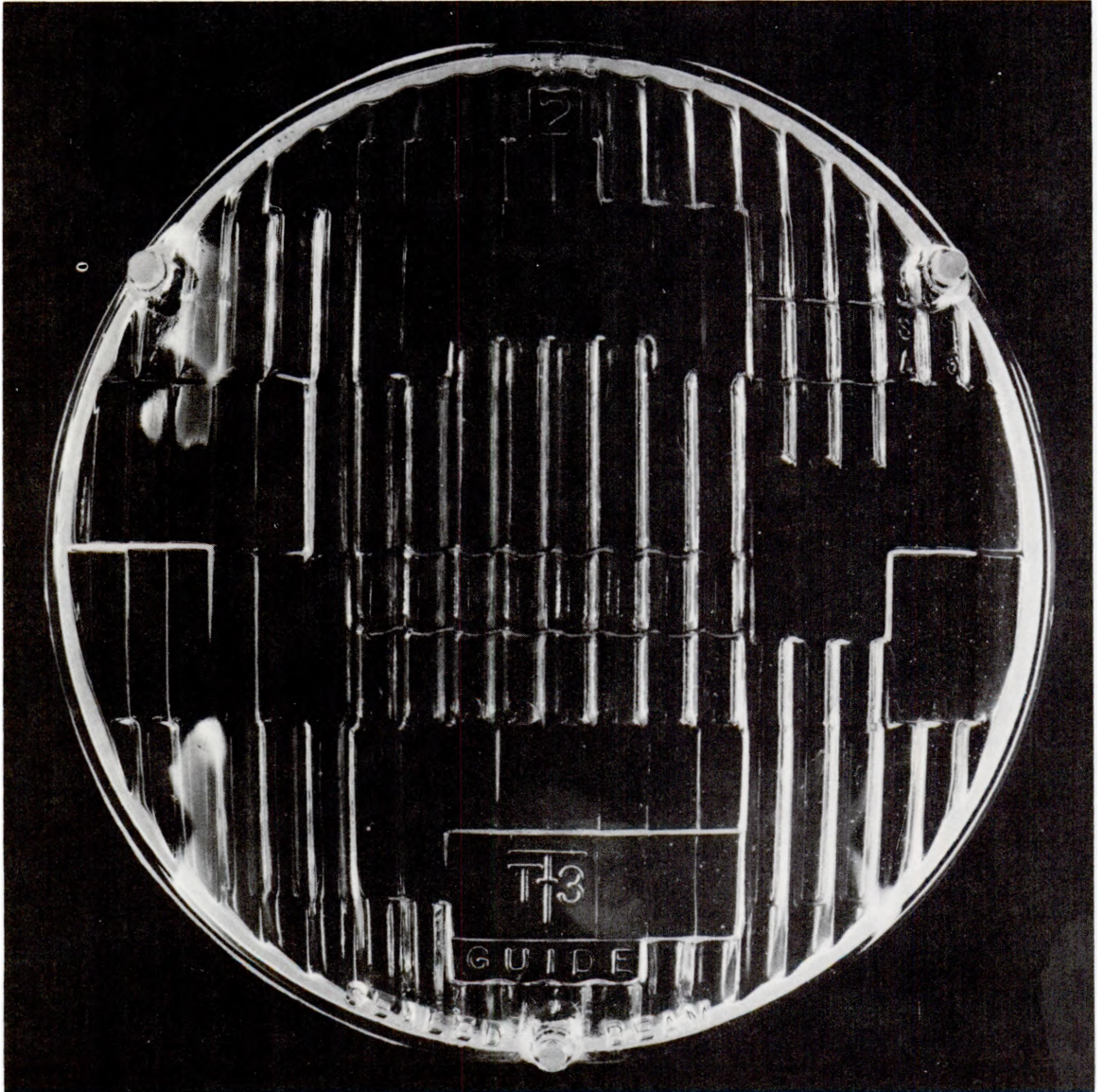

FIGURE A25. *Guide, Type 2.*

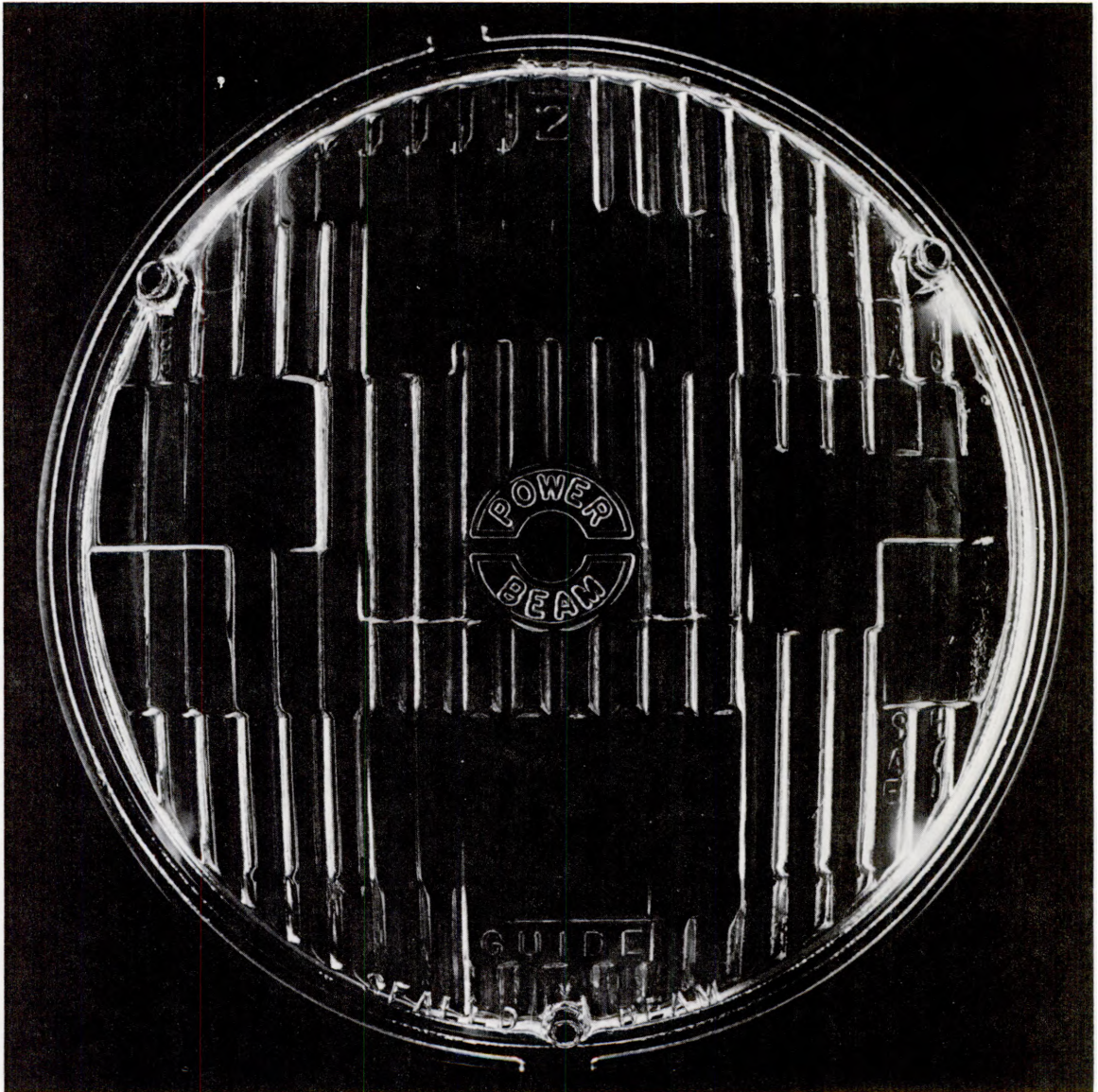

FIGURE A26. *Guide, Type 2.*

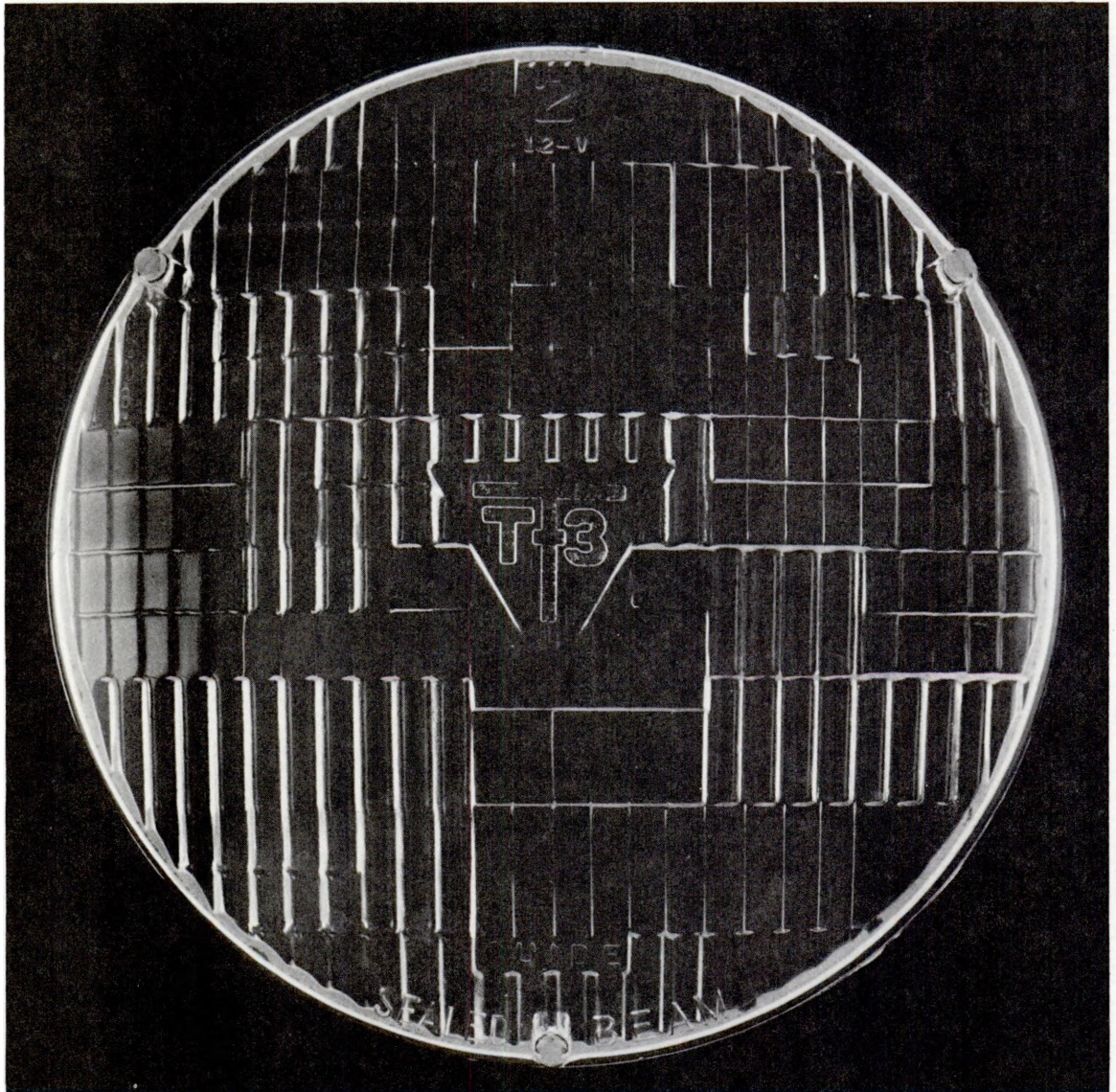

FIGURE A27. *Guide, Type 2, Twin-Beam.*

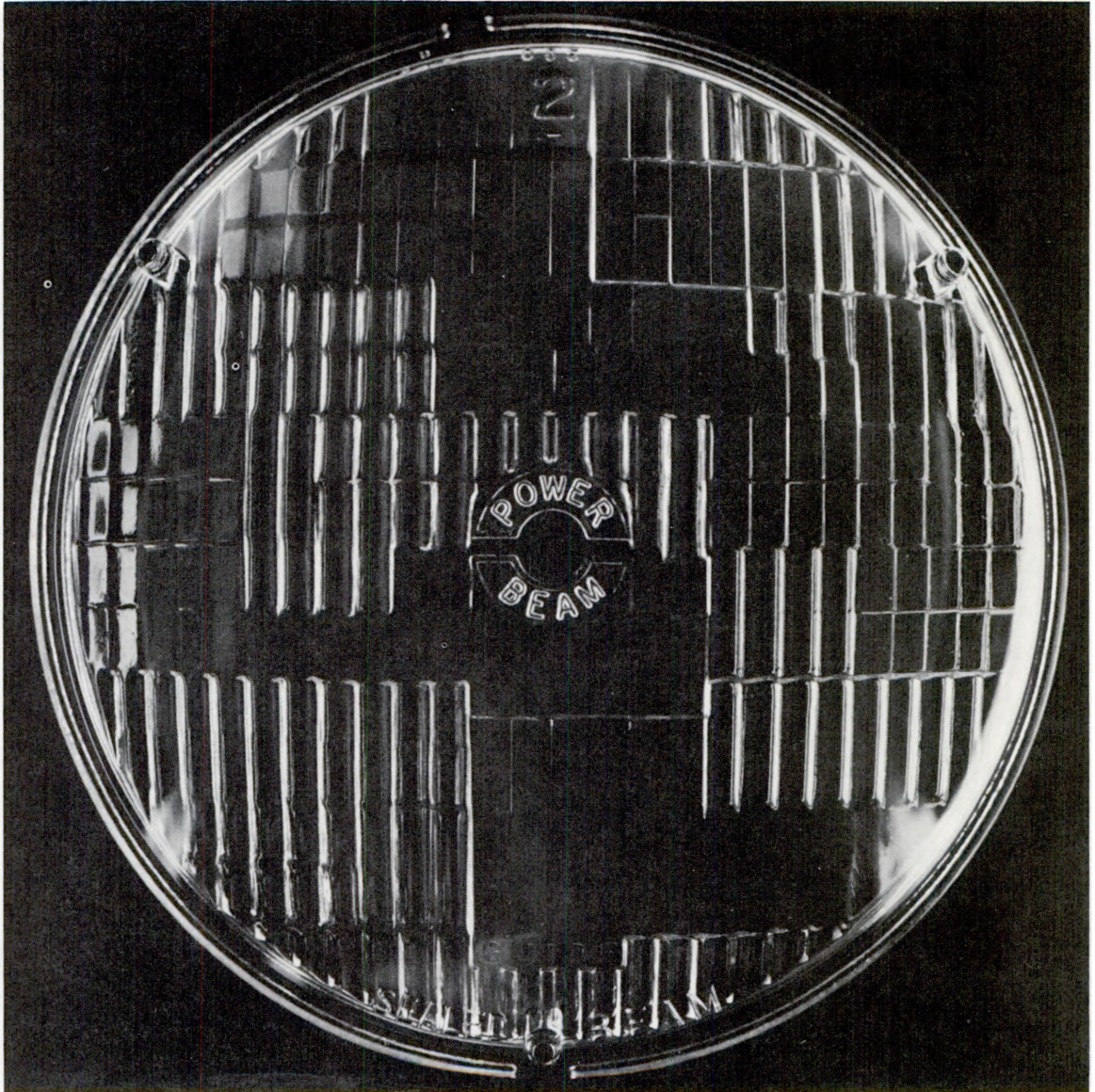

FIGURE A28. *Guide, Type 2, Twin-Beam.*

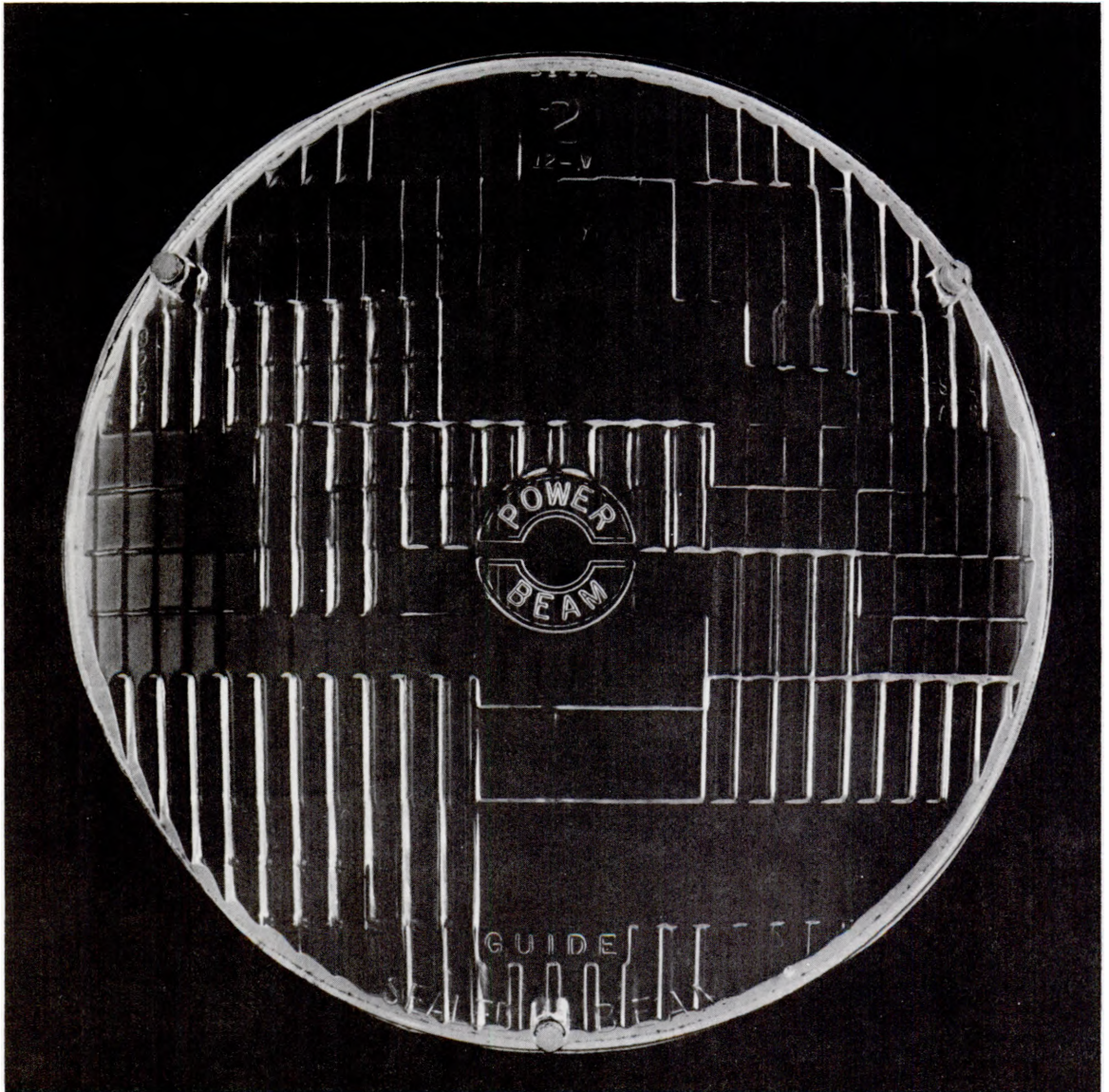

FIGURE A29. *Guide, Type 2, Twin-Beam.*

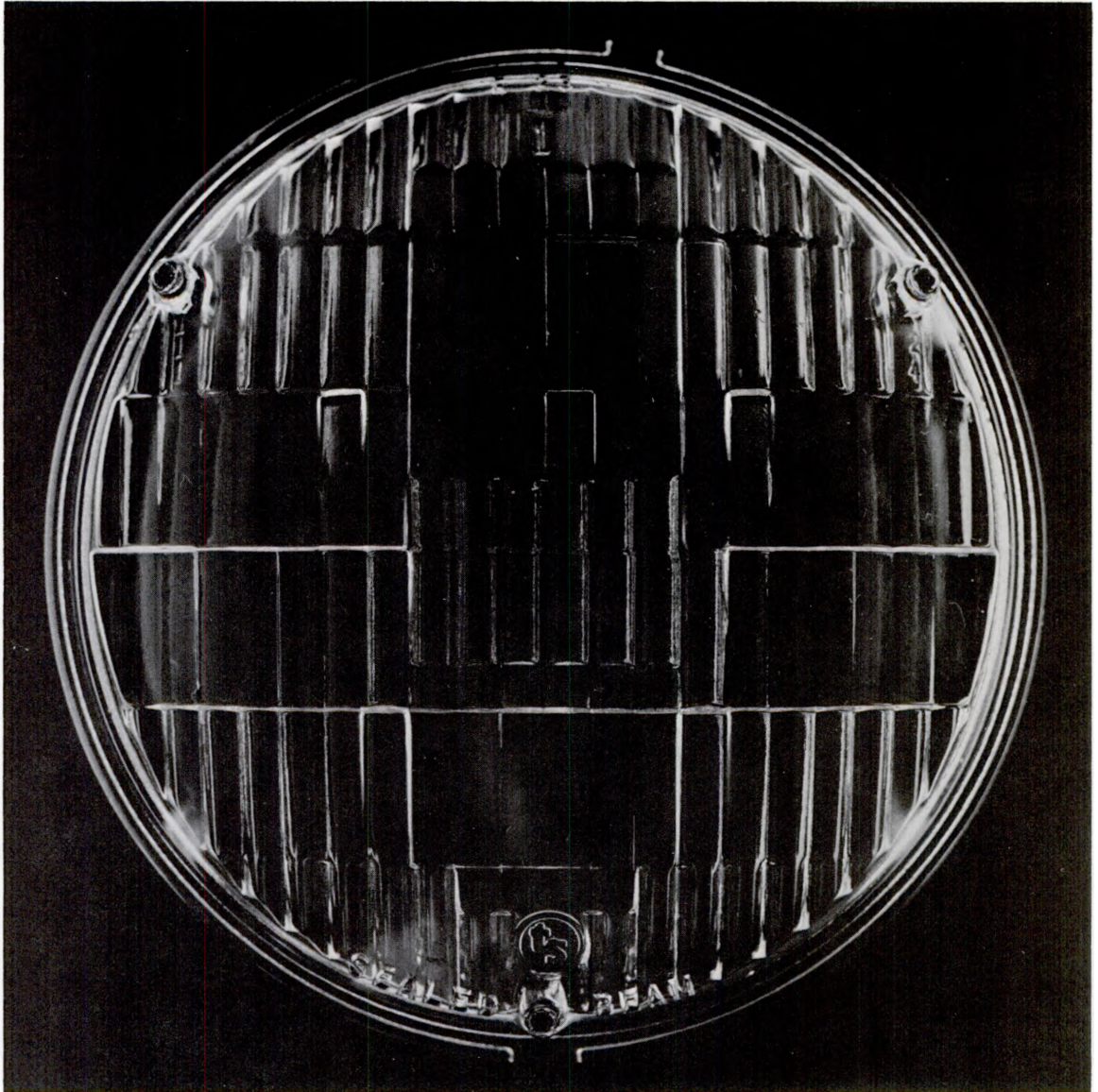

FIGURE A30. *Tung-Sol, Type 1.*

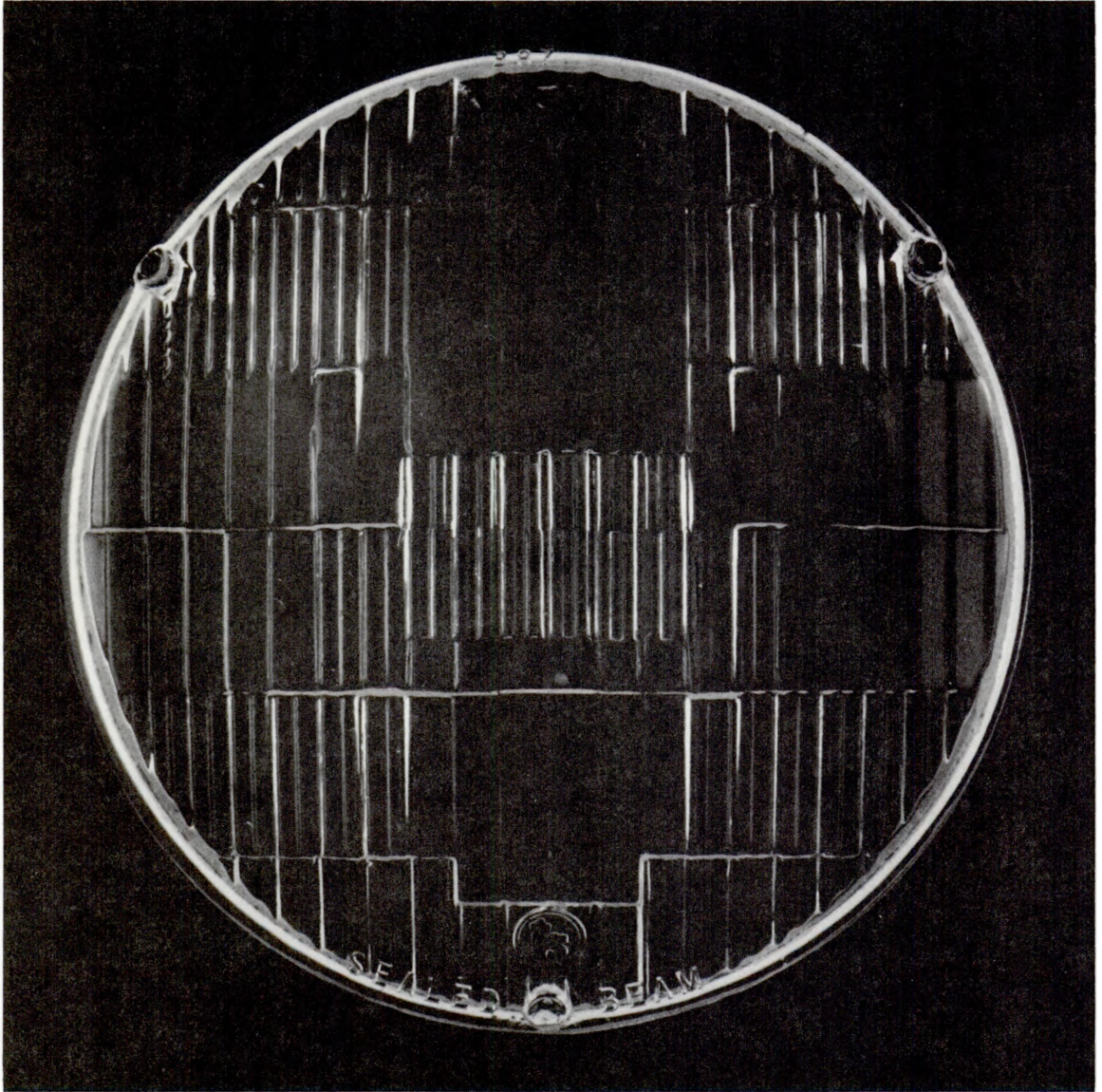

FIGURE A31. *Tung-Sol, Type 1.*

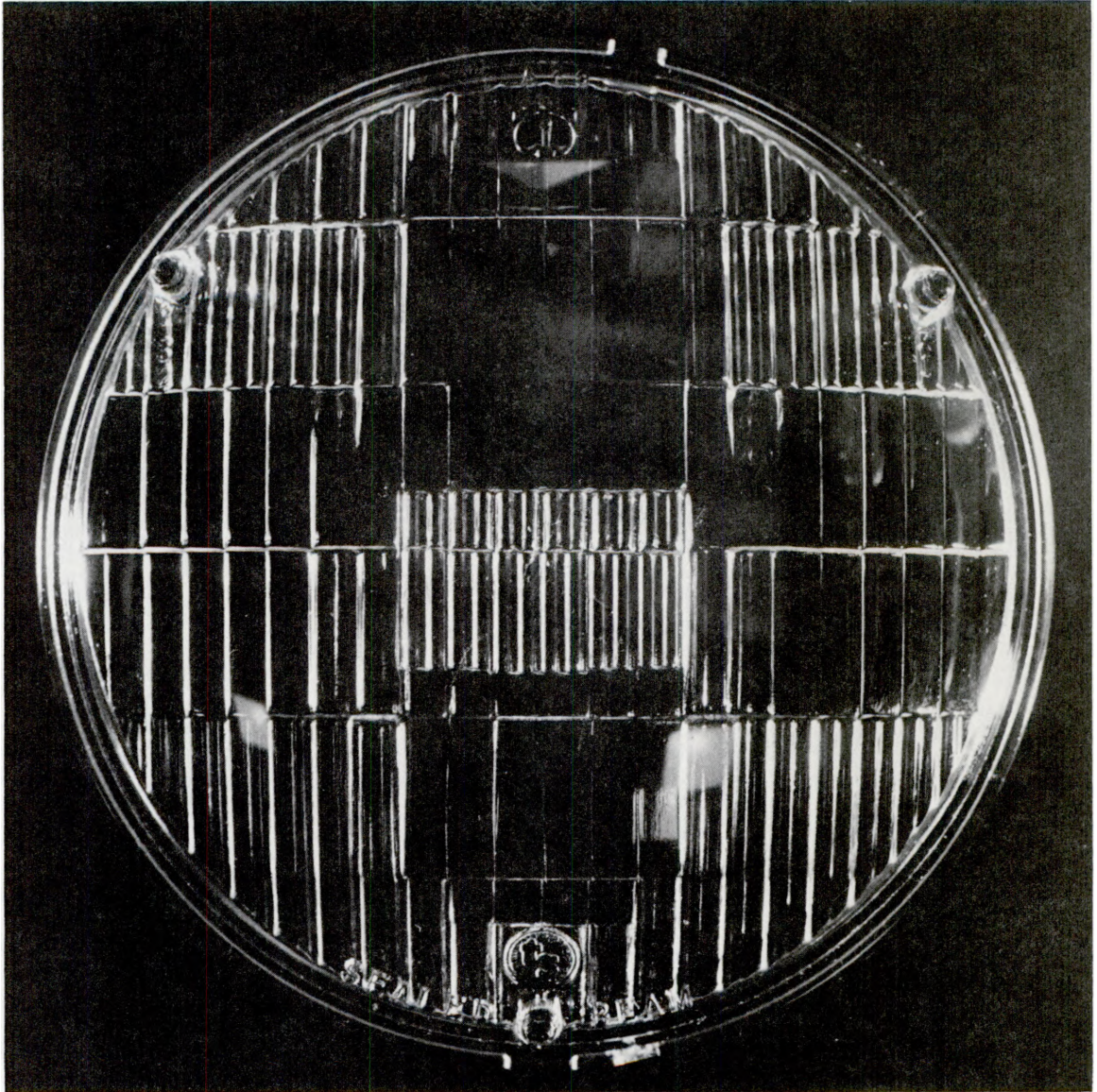

FIGURE A32. *Tung-Sol, Type 1.*

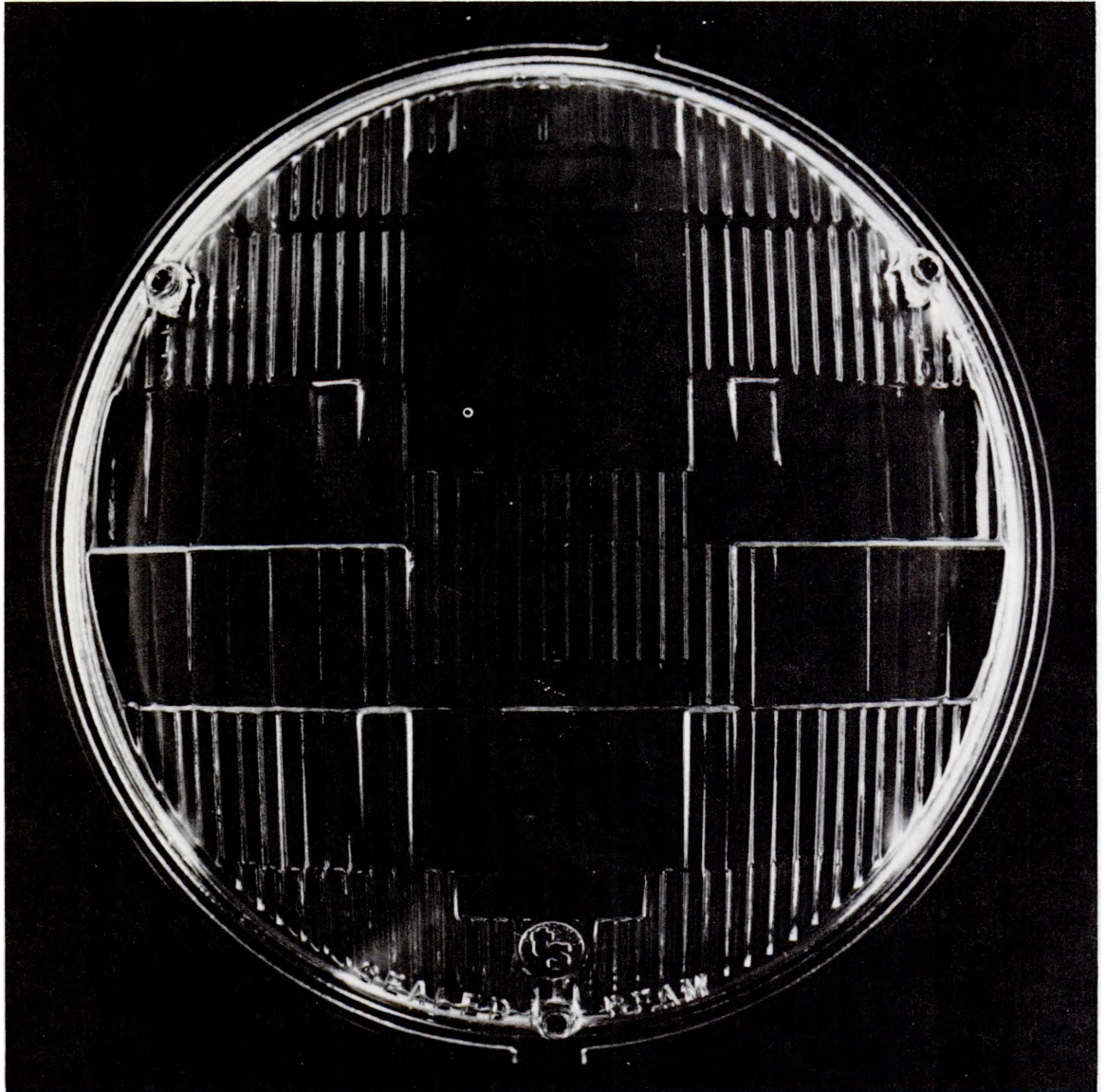

FIGURE A33. *Tung-Sol, Type 1.*

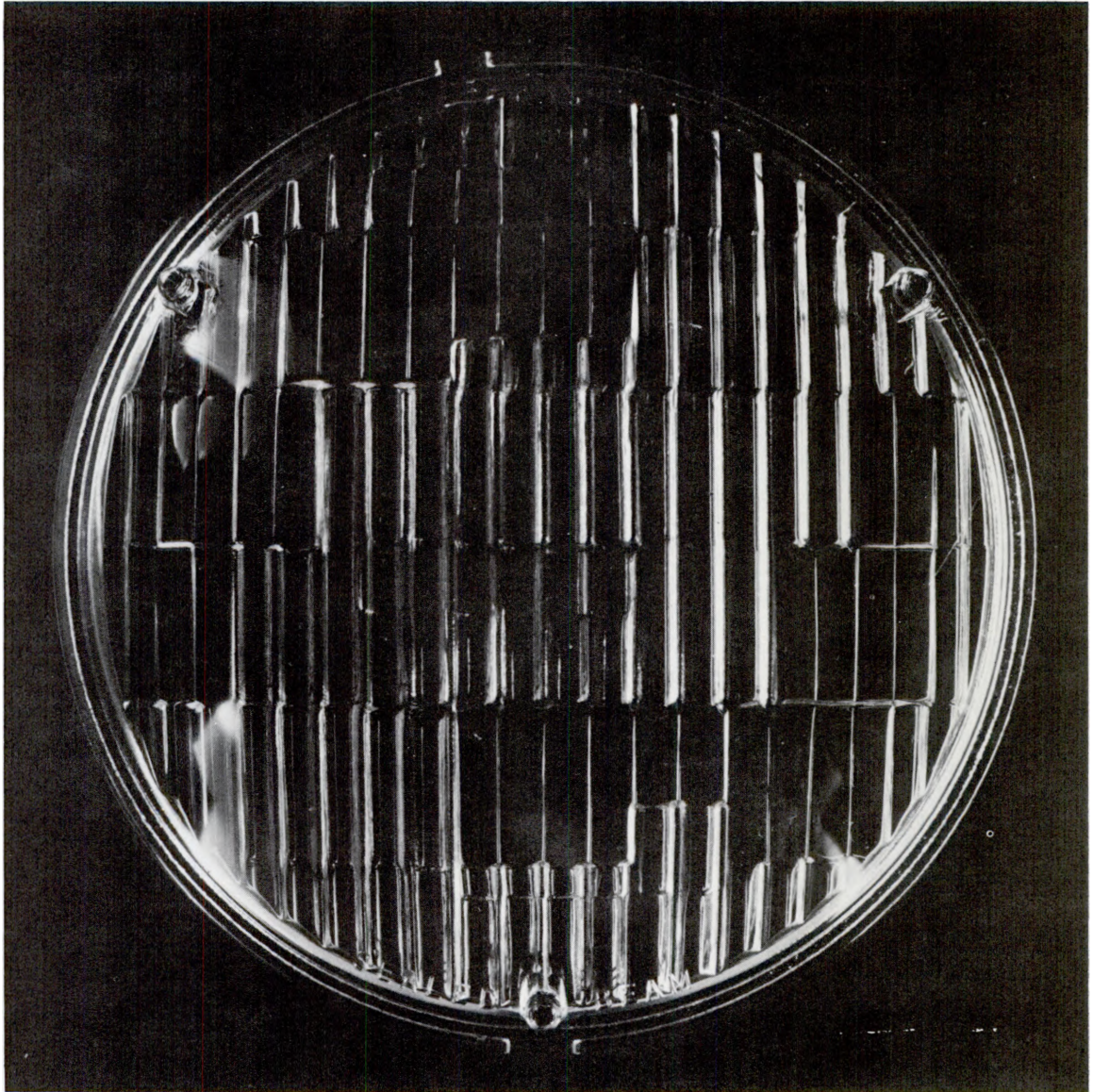

FIGURE A34. *Tung-Sol, Type 2.*

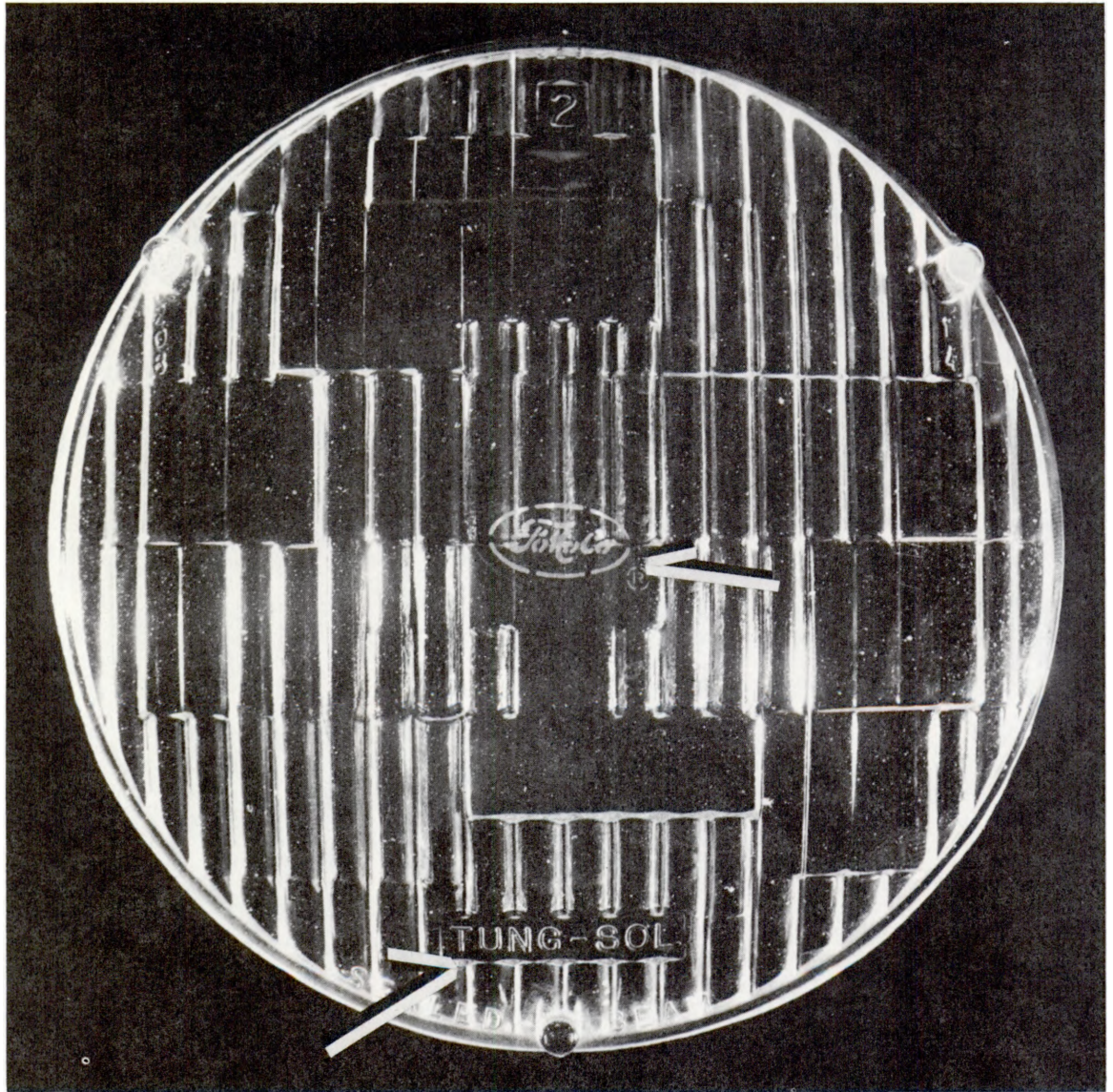

FIGURE A35. *Tung-Sol, Type 2.*

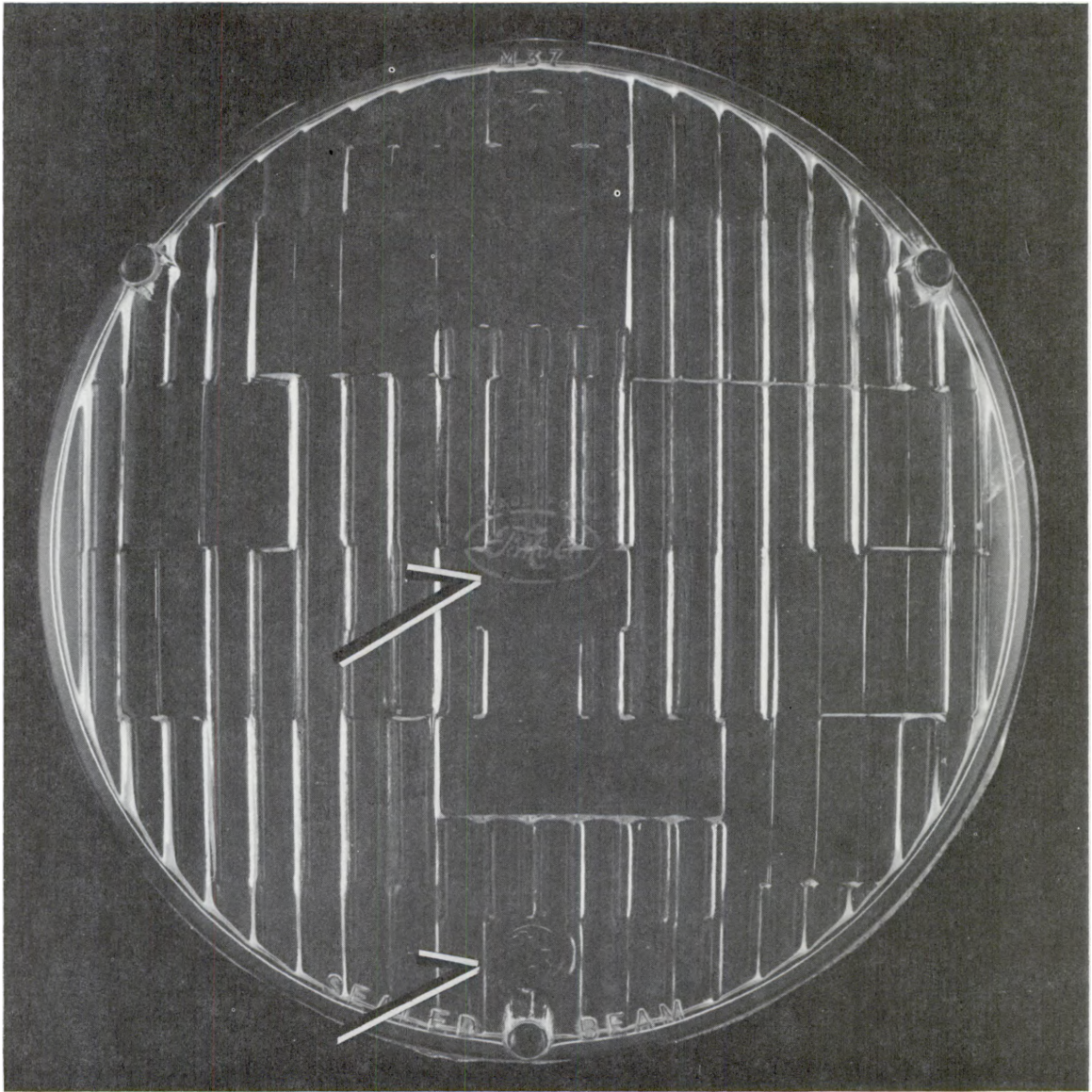

FIGURE A36. *Tung-Sol, Type 2.*

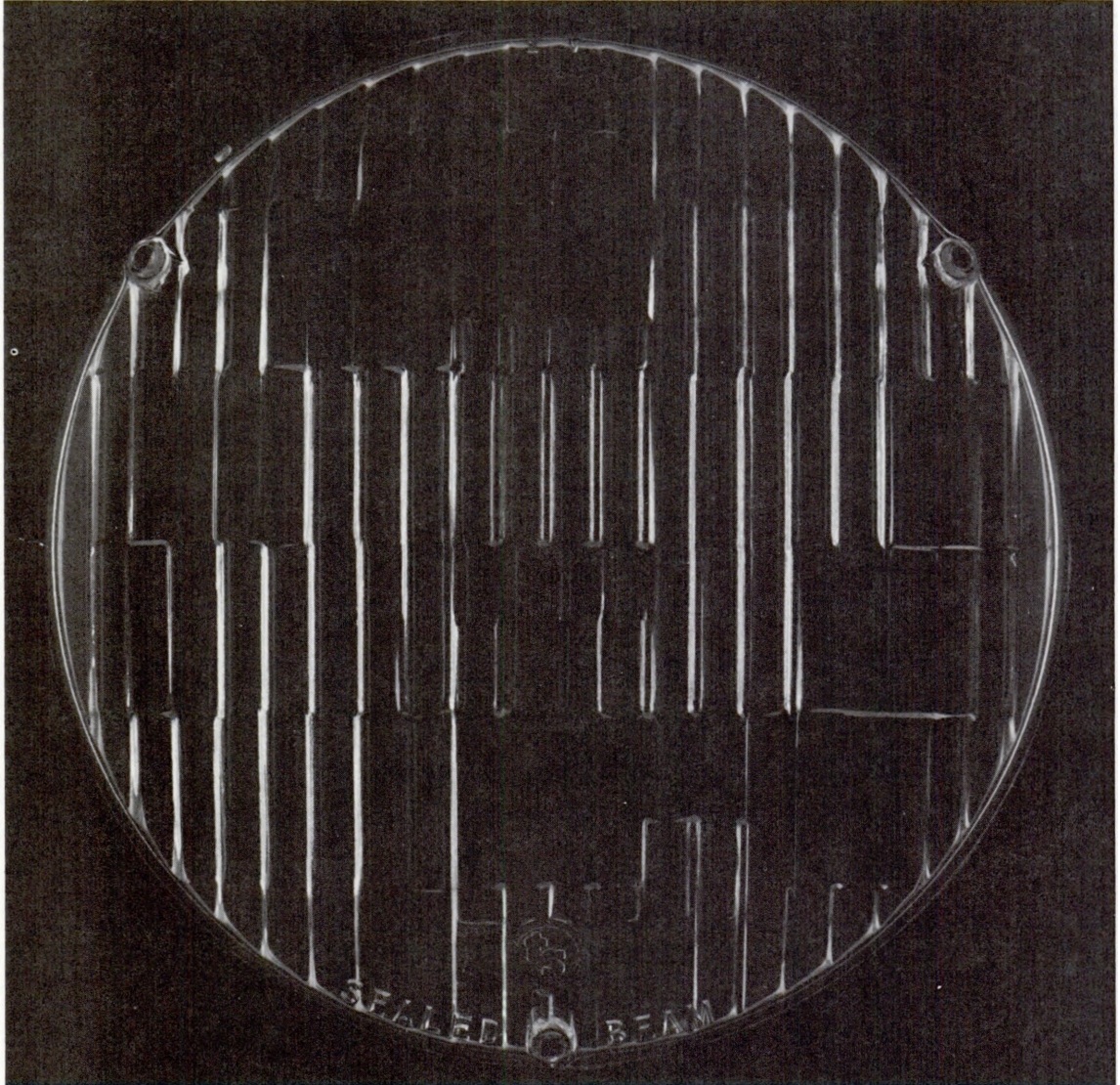

FIGURE A37. *Tung-Sol, Type 2.*

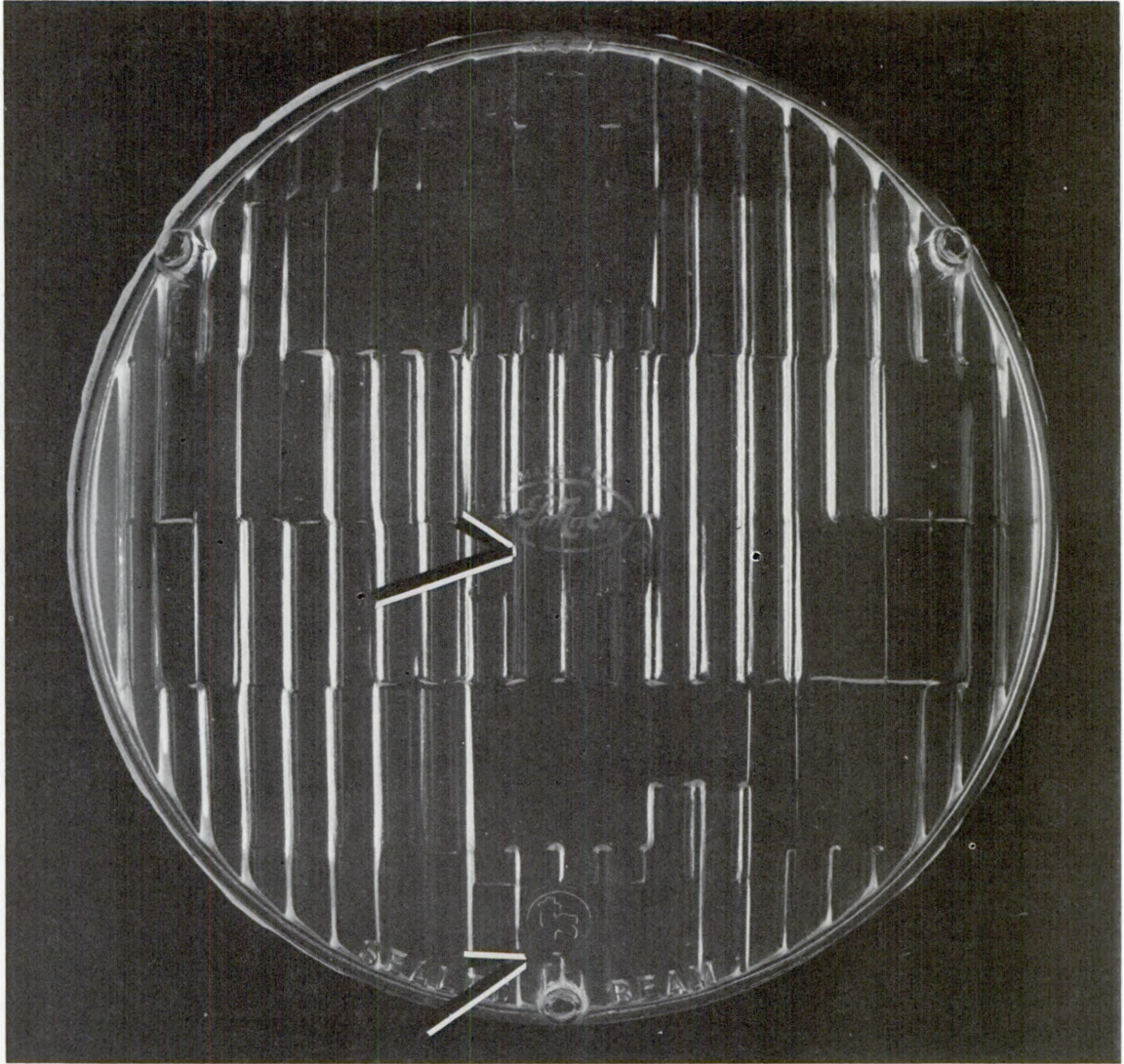

FIGURE A38. *Tung-Sol, Type 2.*

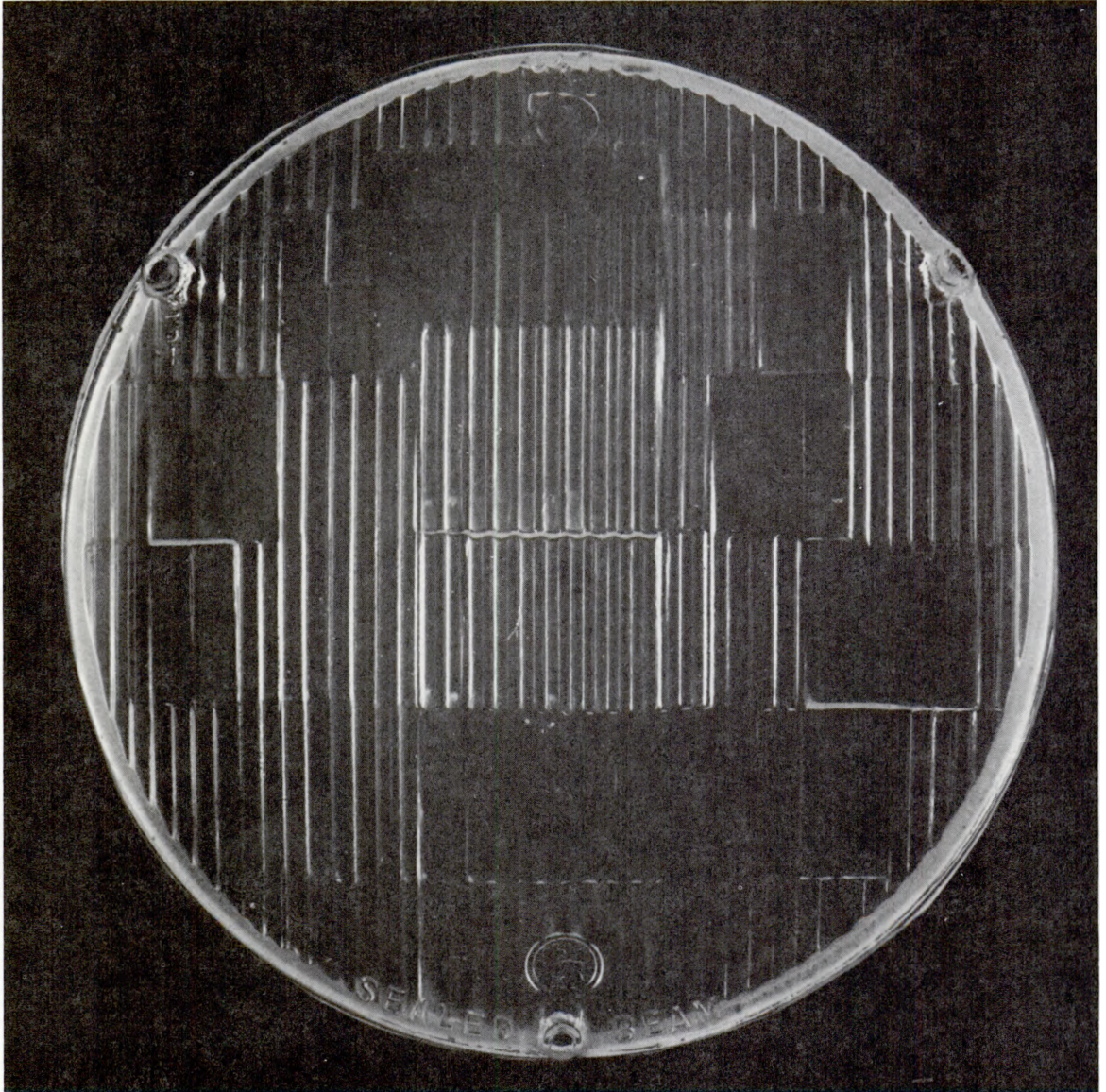

FIGURE A39. *Tung-Sol, Type 2.*

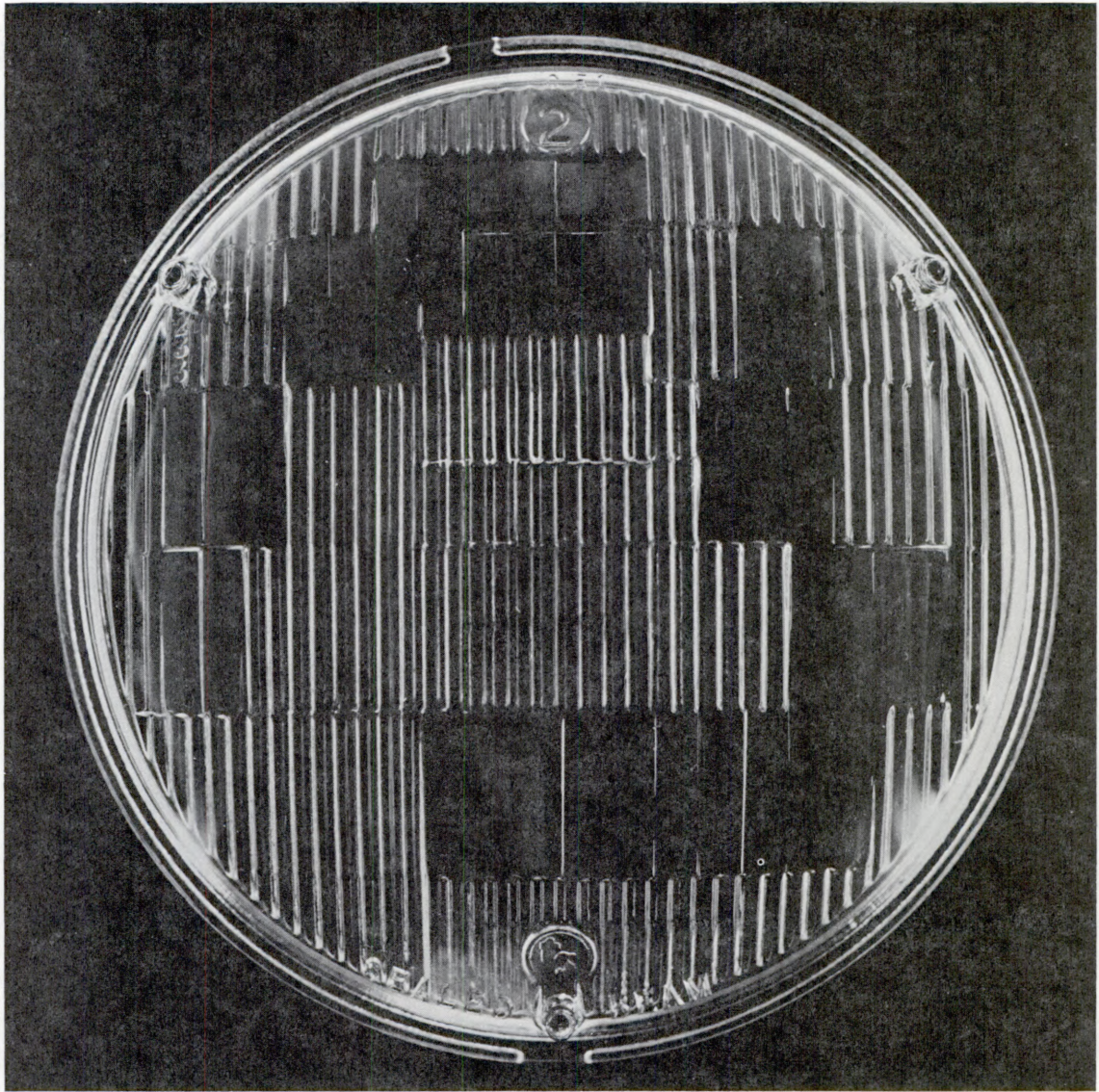

FIGURE A40. *Tung-Sol, Type 2.*

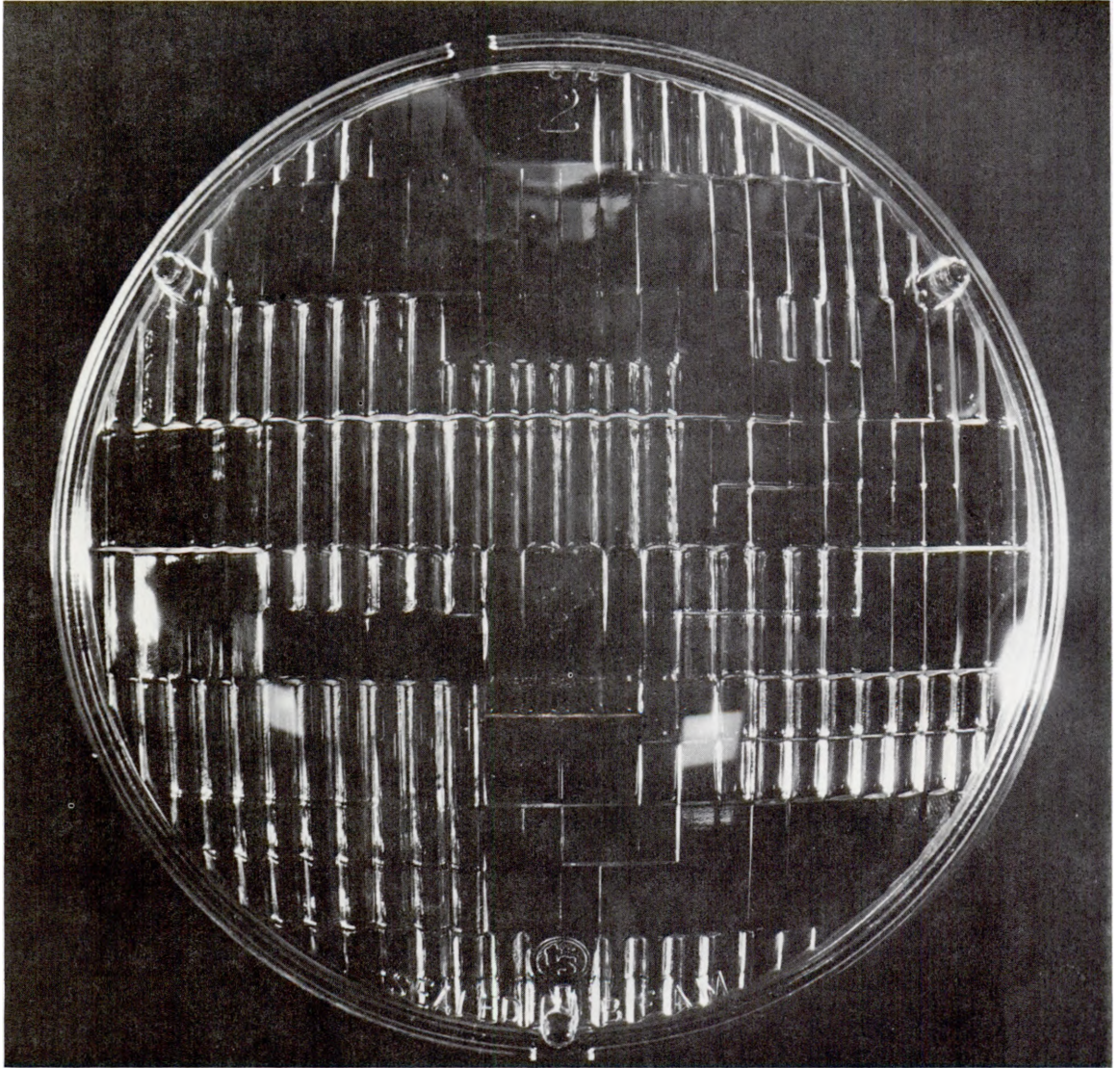

FIGURE A41. *Tung-Sol, Type 2, Twin-Beam.*

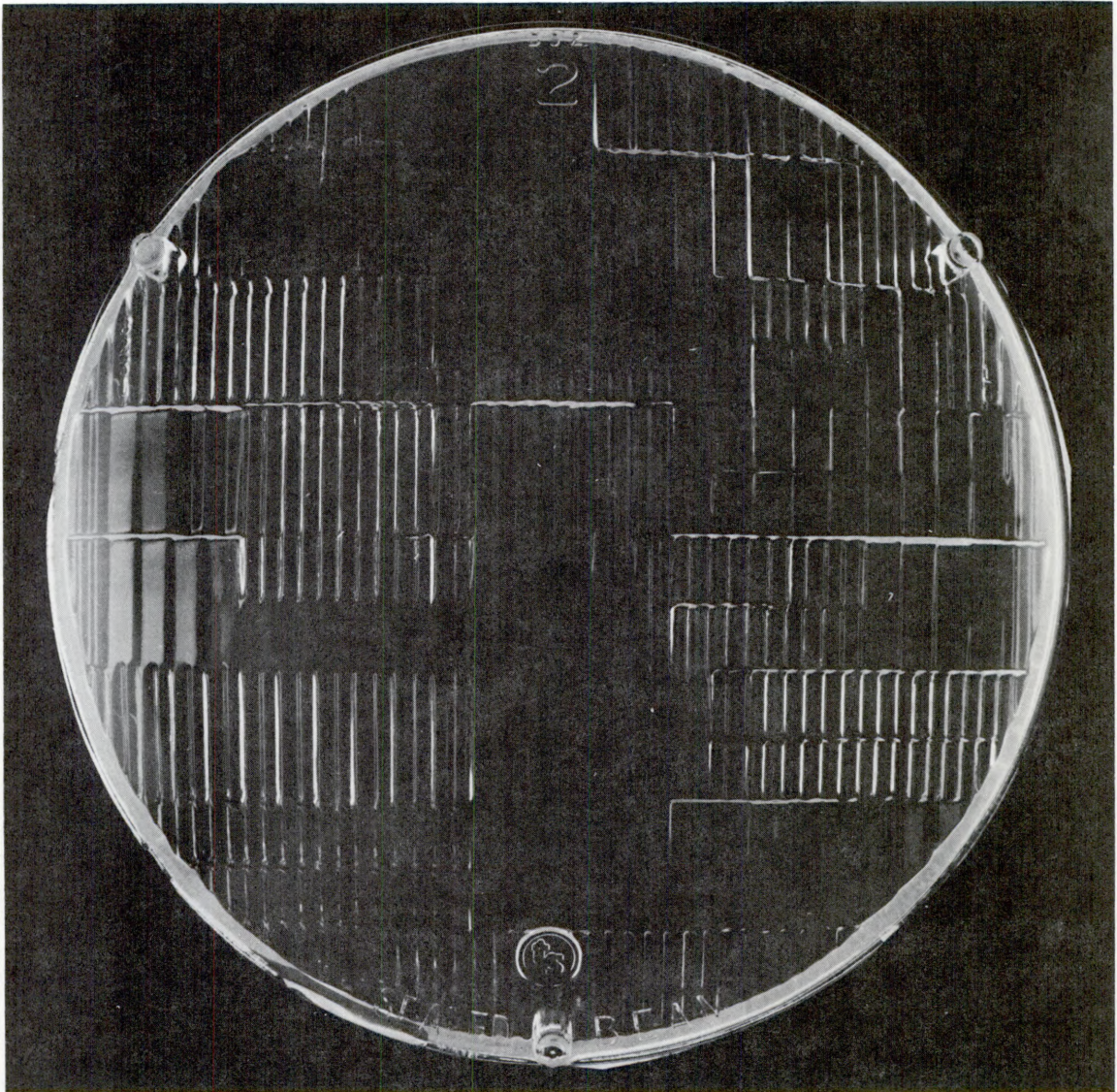

FIGURE A42. *Tung-Sol, Type 2, Twin-Beam.*

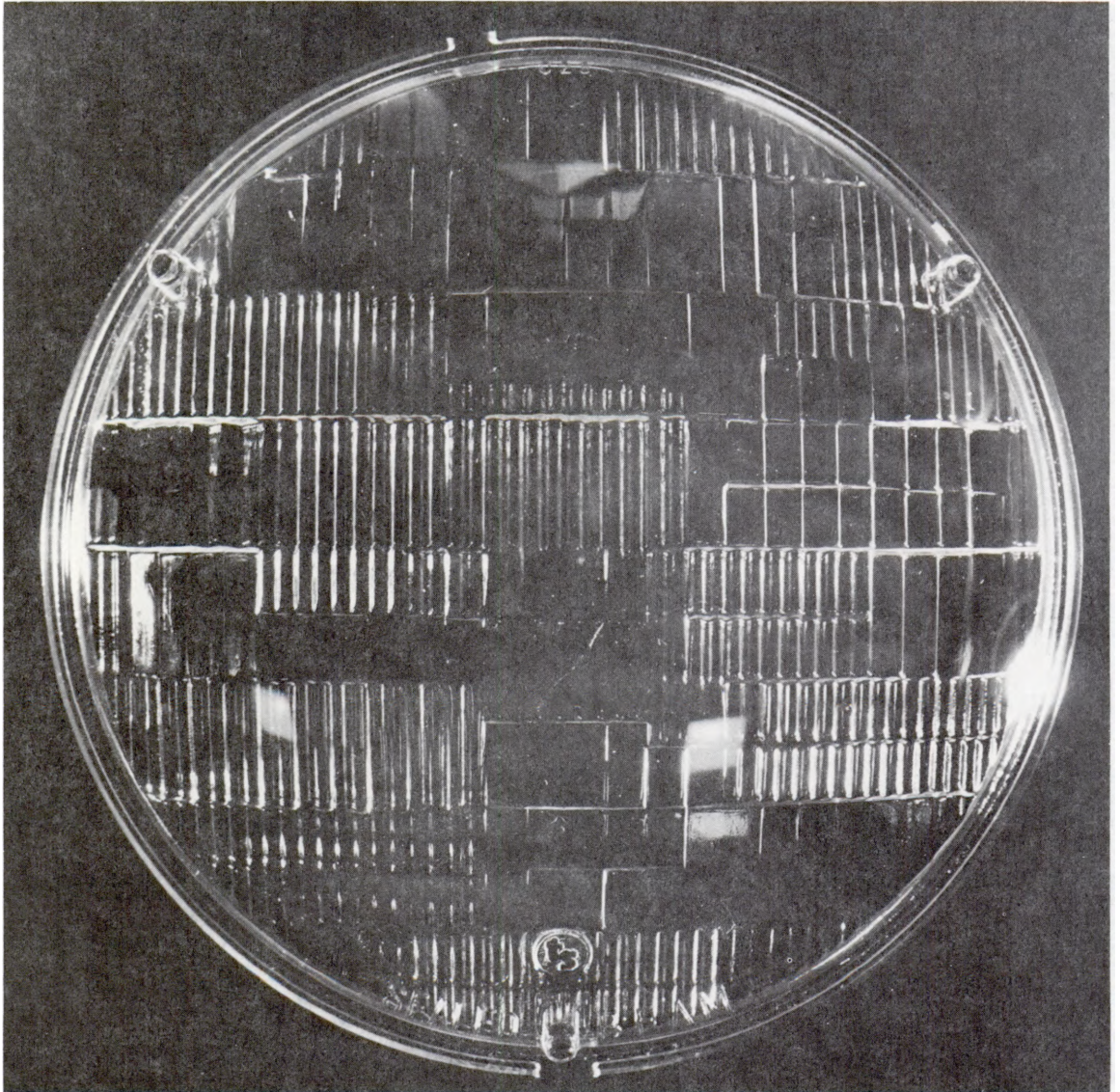

FIGURE A43. *Tung-Sol, Type 2, Twin-Beam.*

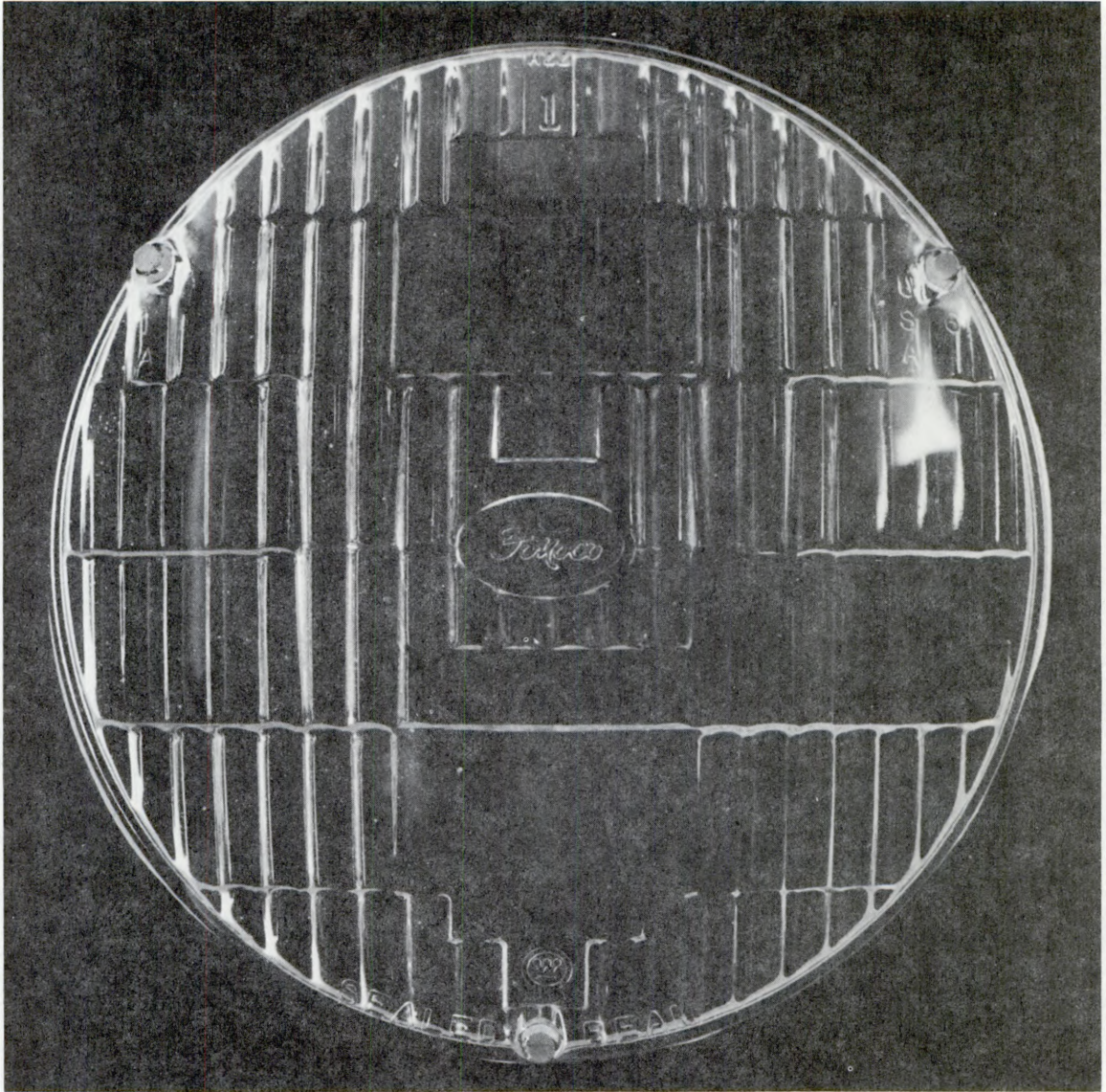

FIGURE A44. *Westinghouse, Type 1.*

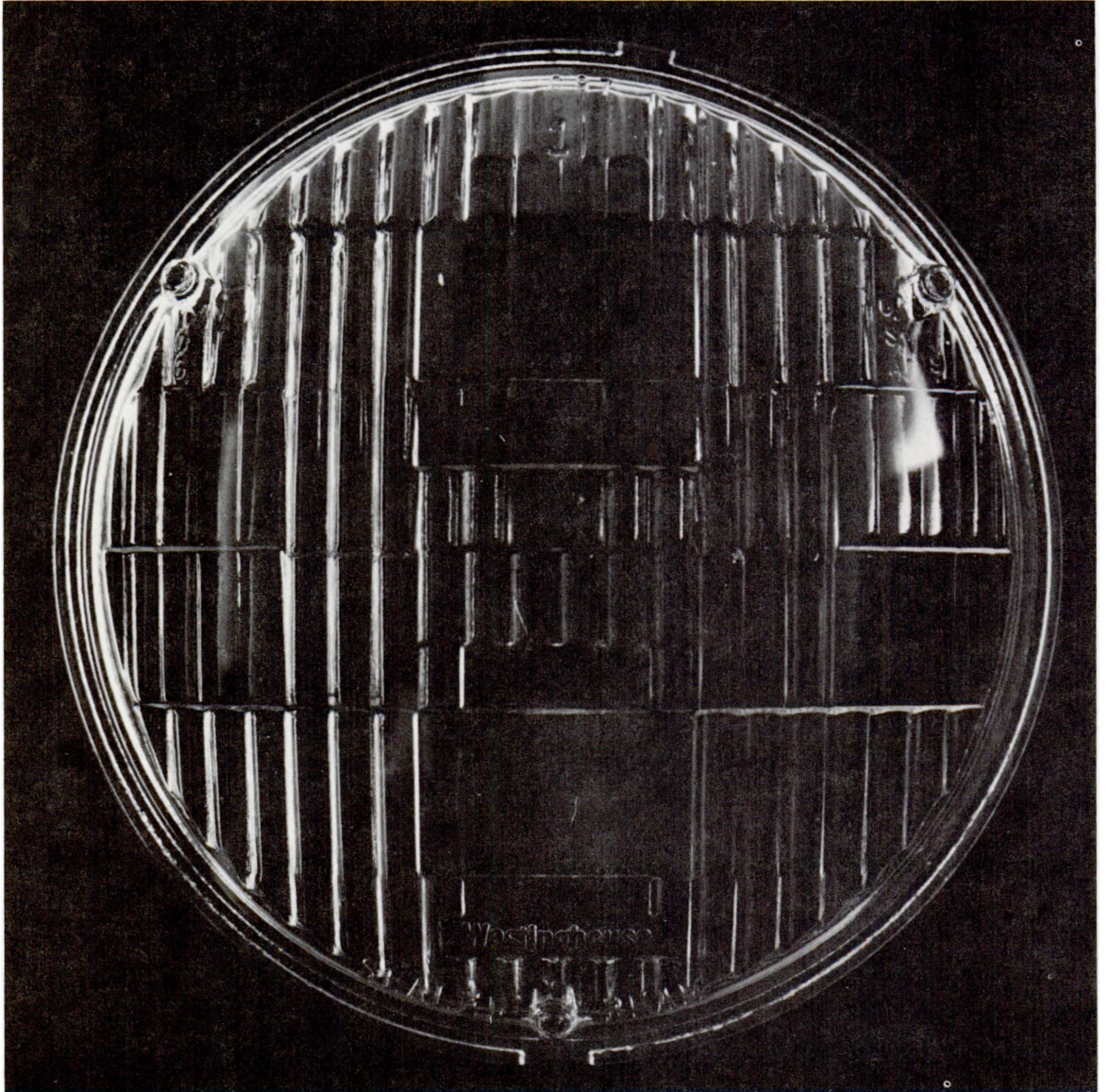

FIGURE A45. *Westinghouse, Type 1.*

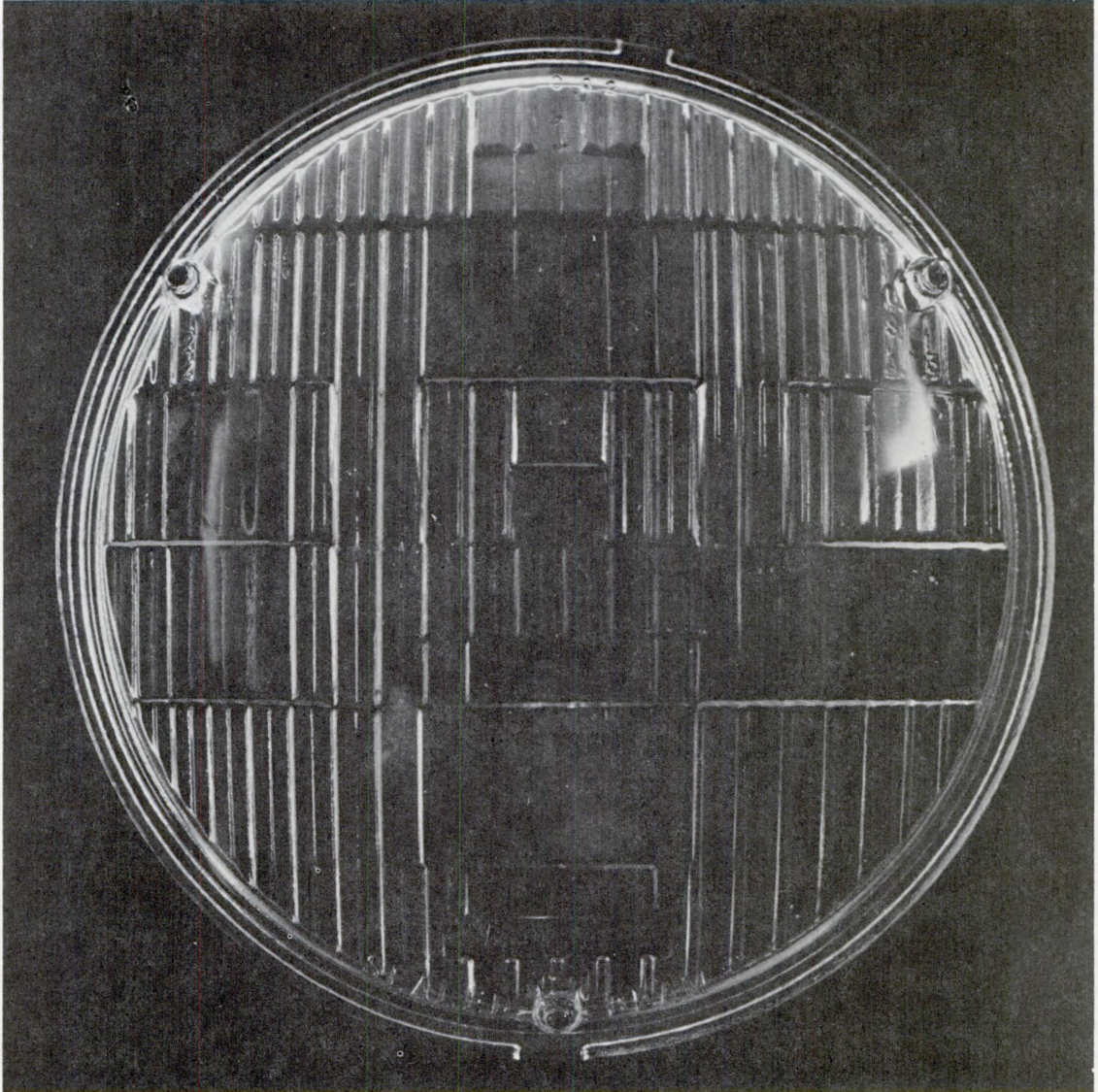

FIGURE A46. *Westinghouse, Type 1.*

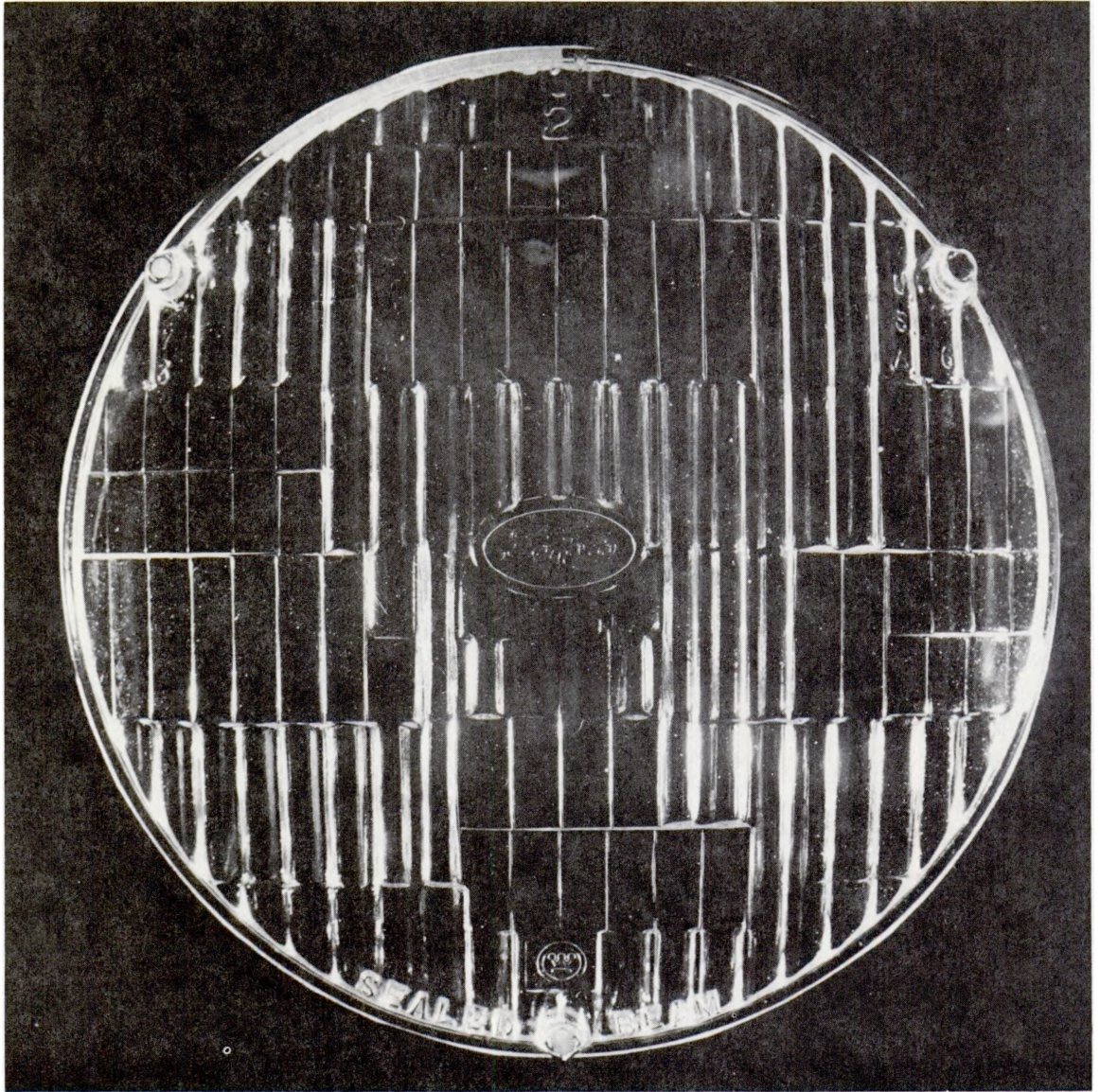

FIGURE A47. *Westinghouse, Type 2.*

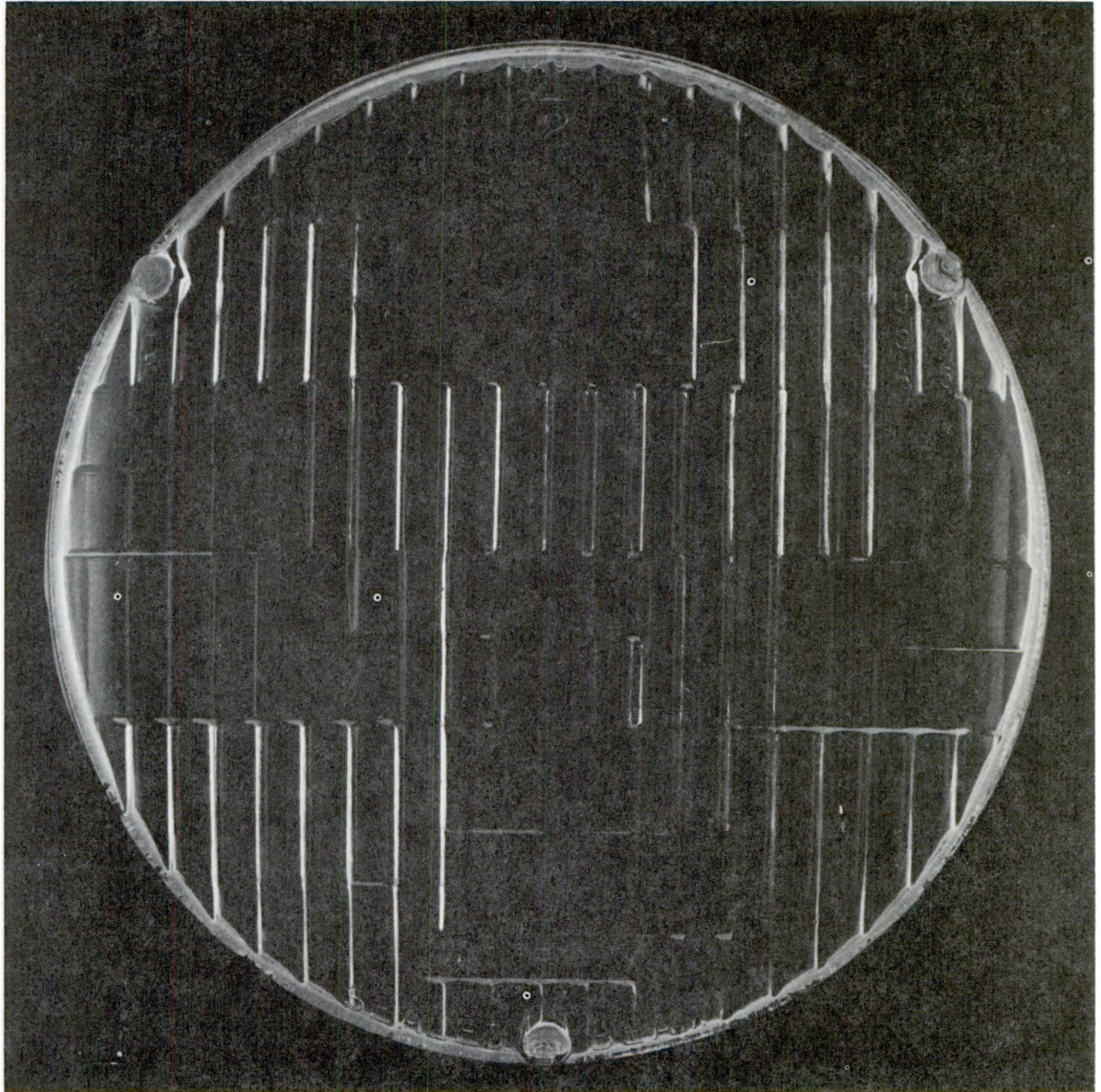

FIGURE A48. *Westinghouse, Type 2.*

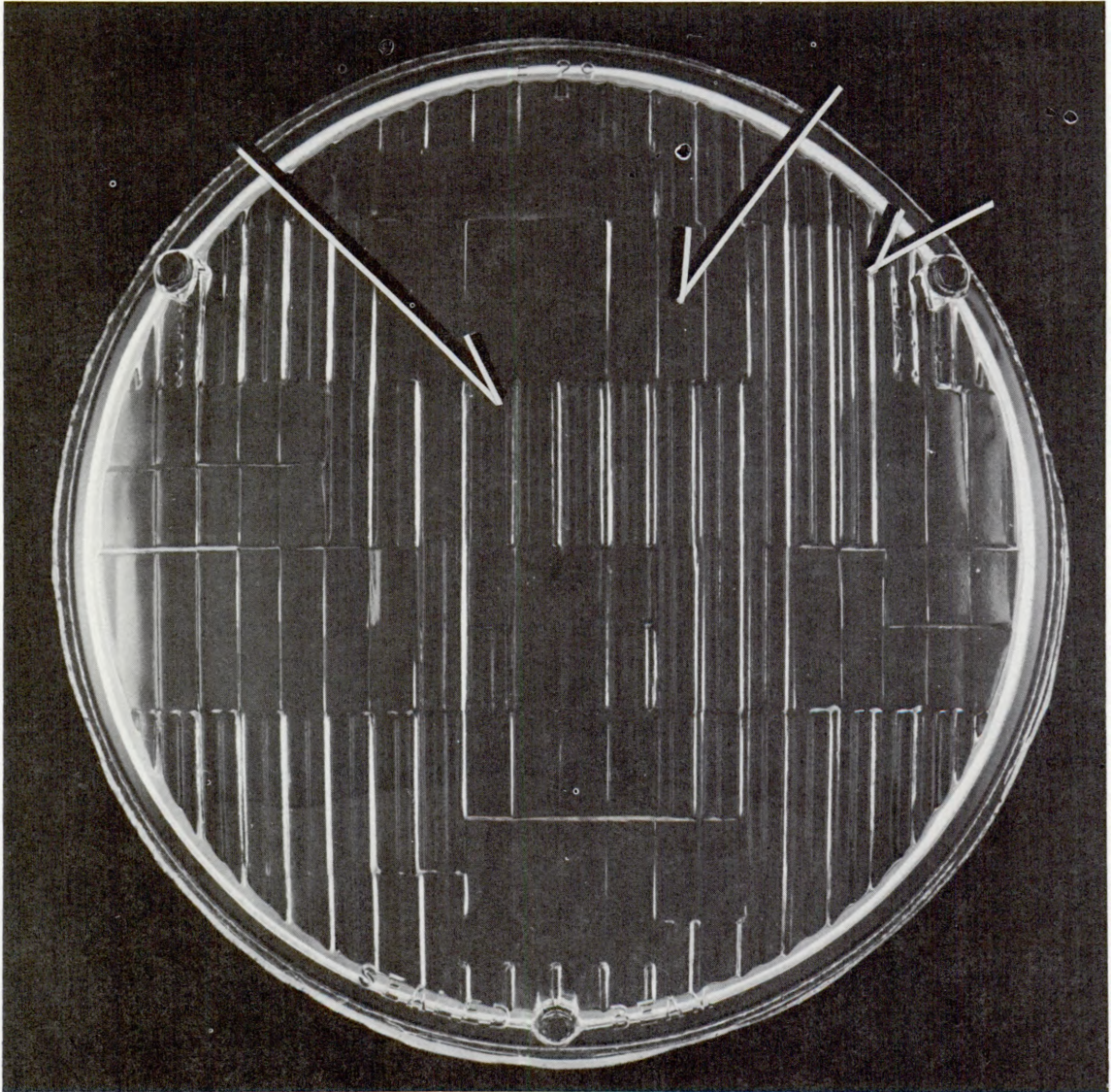

FIGURE A49. *Westinghouse, Type 2.*

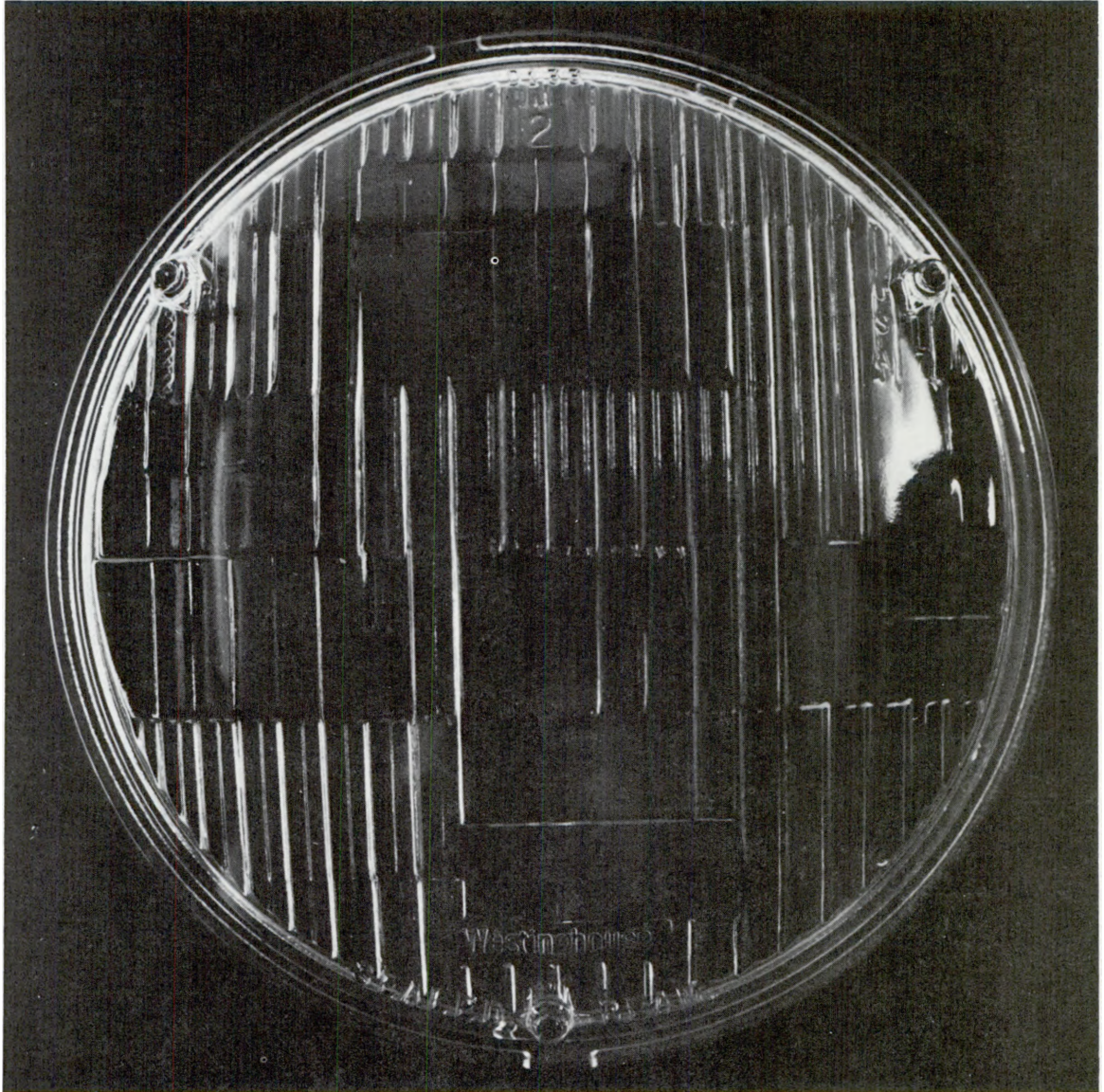

FIGURE A50. *Westinghouse, Type 2.*

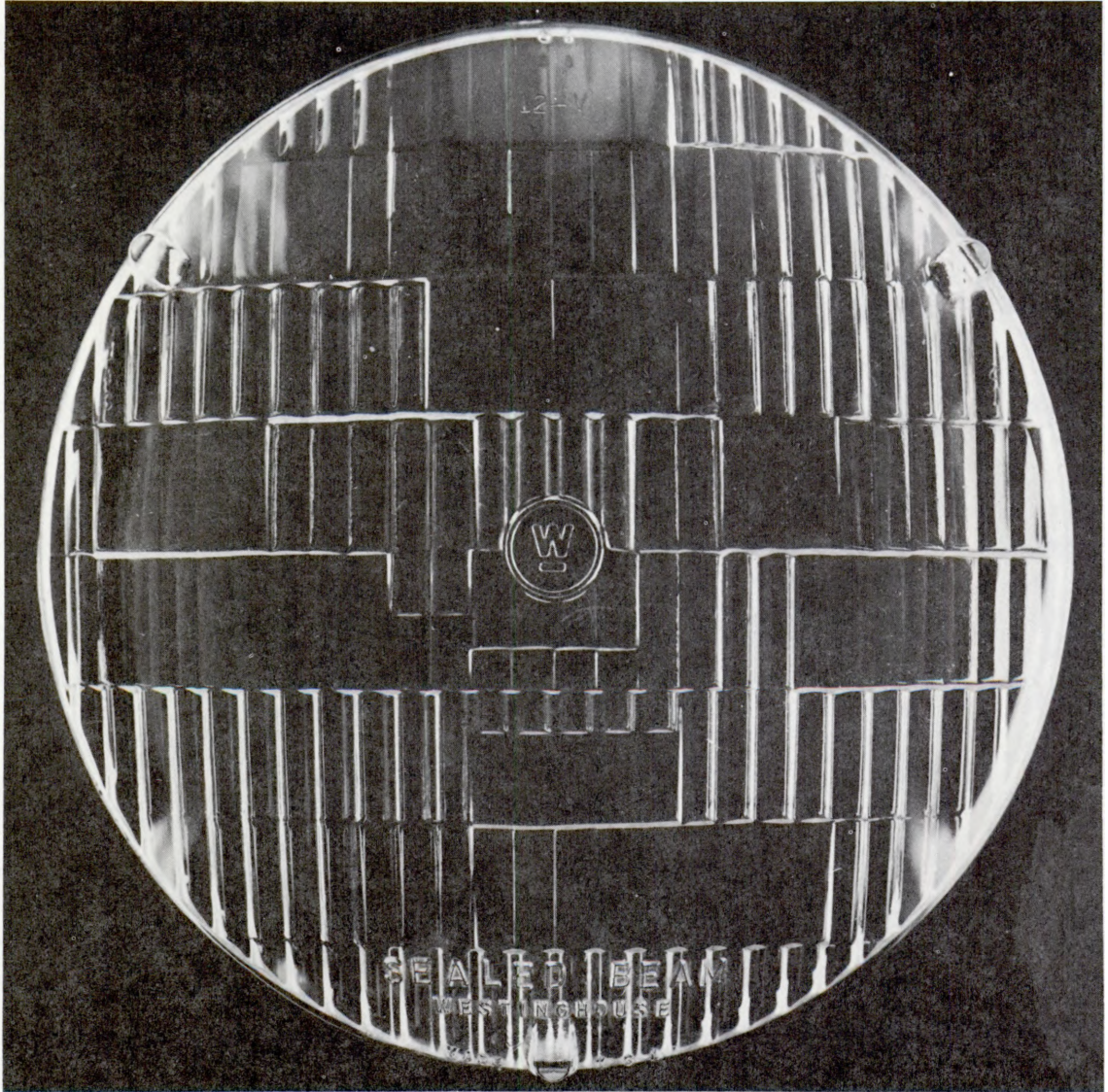

FIGURE A51. *Westinghouse, Type 2.*

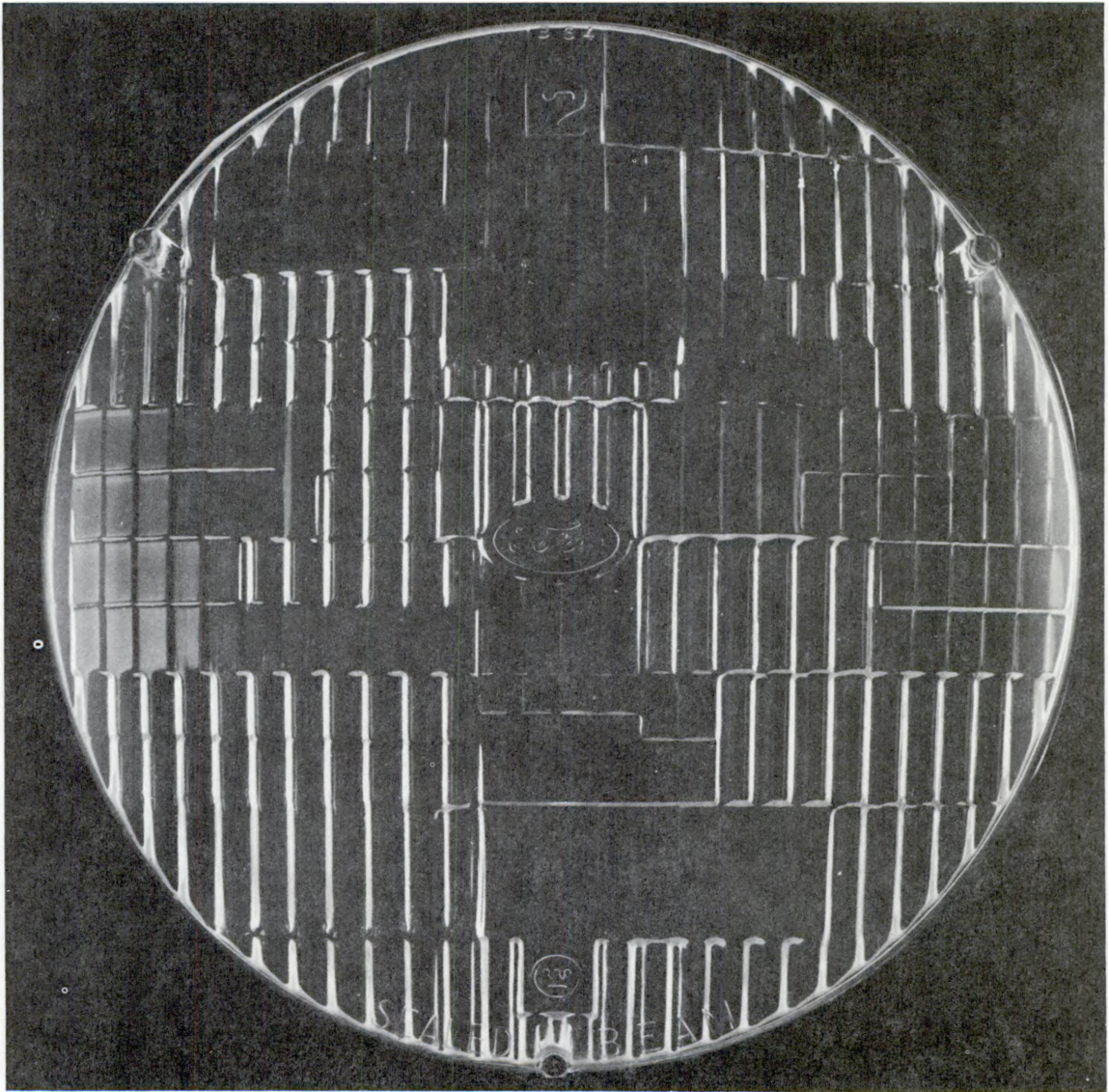

FIGURE A52. *Westinghouse, Type 2, Twin-Beam.*

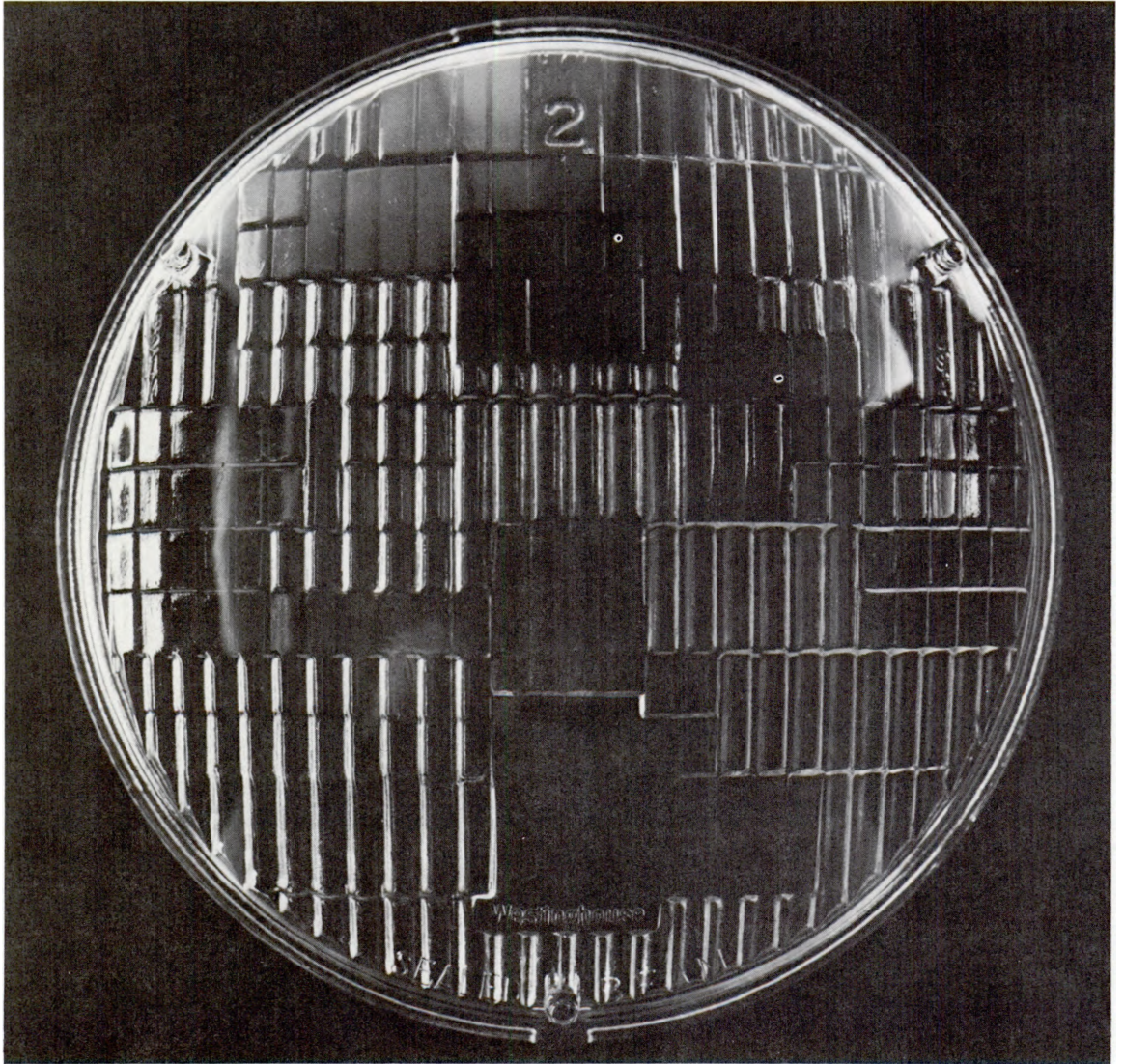

FIGURE A53. *Westinghouse, Type 2, Twin-Beam.*

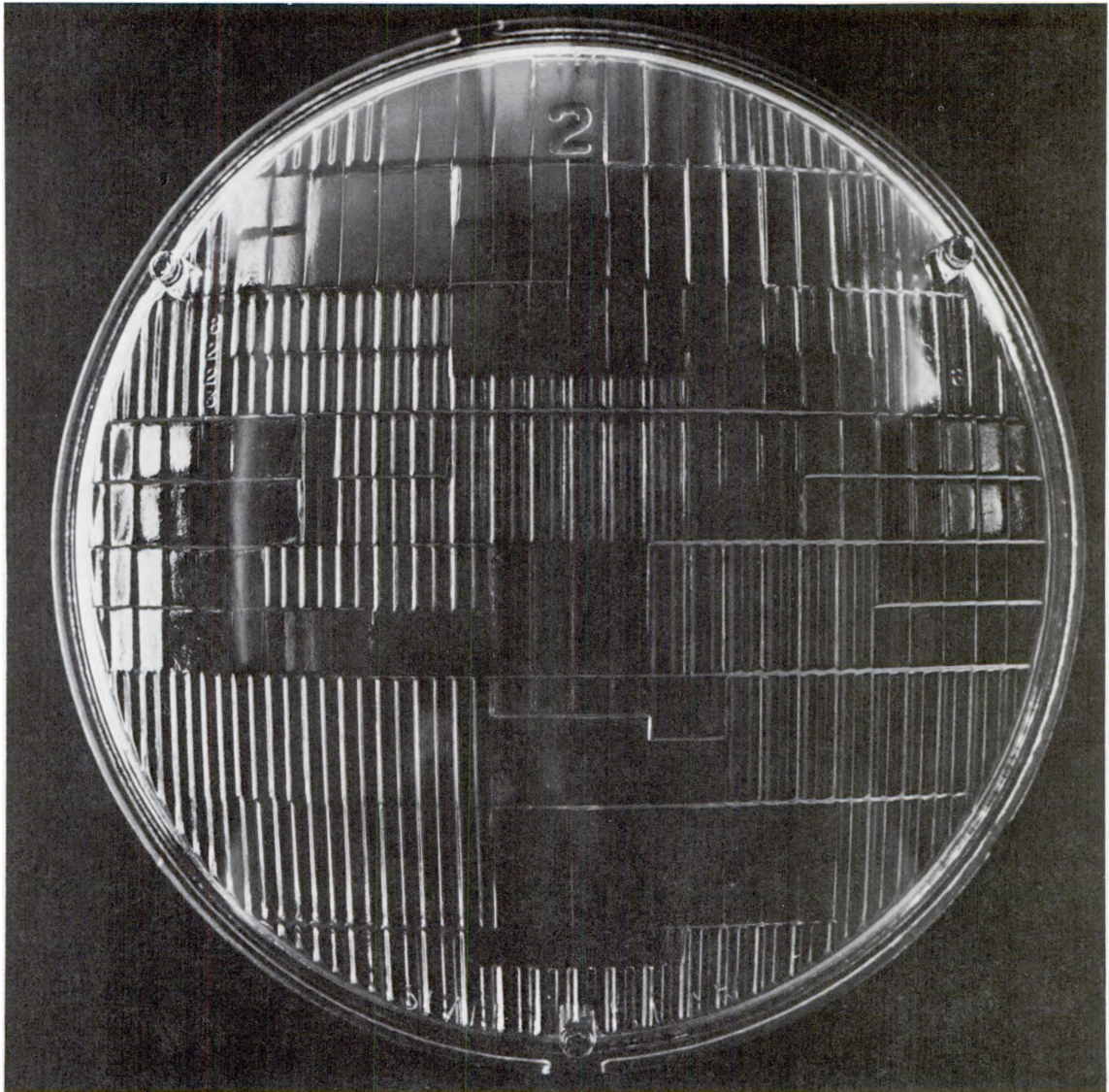

FIGURE A54. *Westinghouse, Type 2, Twin-Beam.*

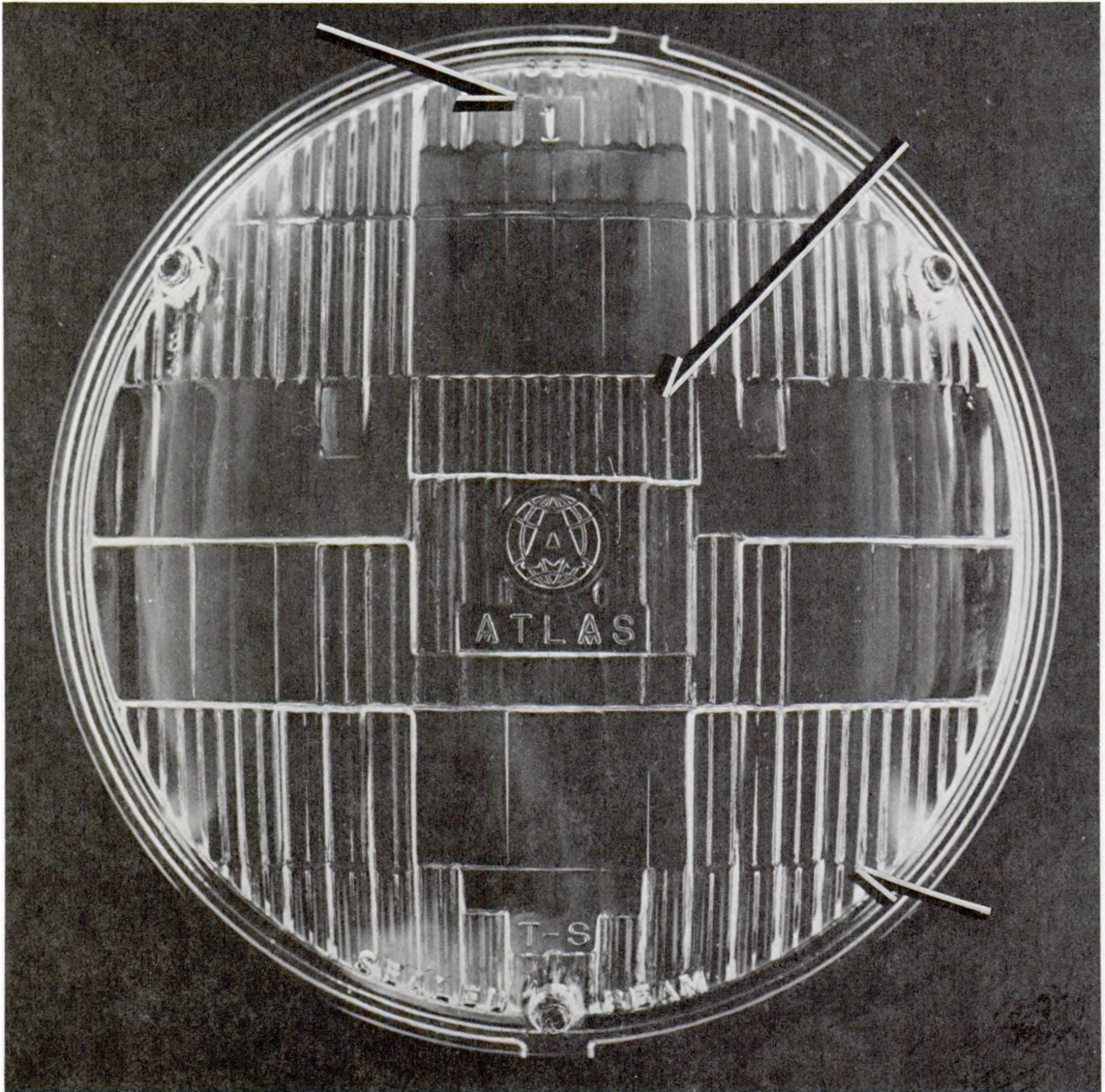

FIGURE A55. *Atlas/Tung-Sol, Type 1.*

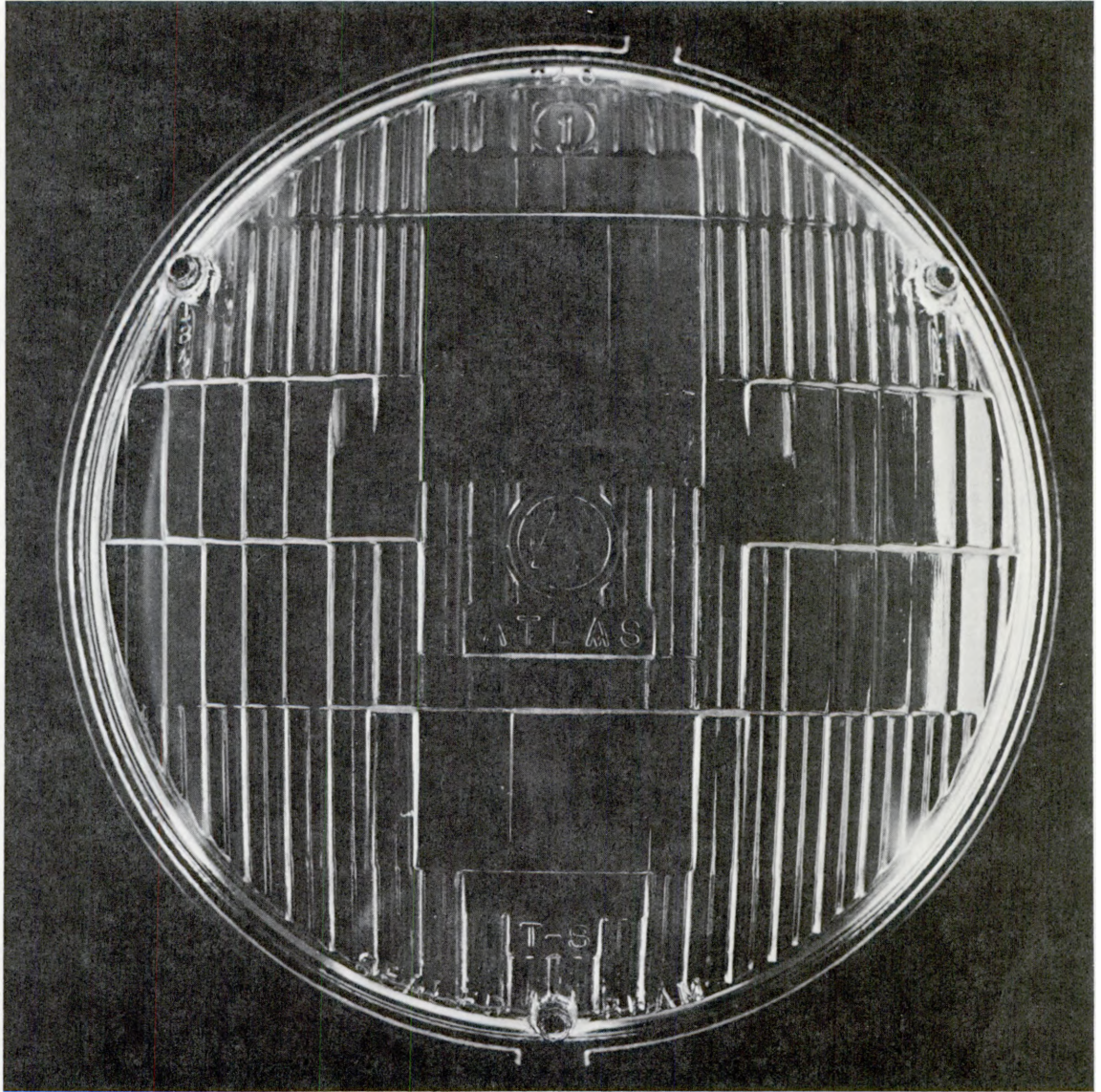

FIGURE A56. *Atlas/Tung-Sol, Type I.*

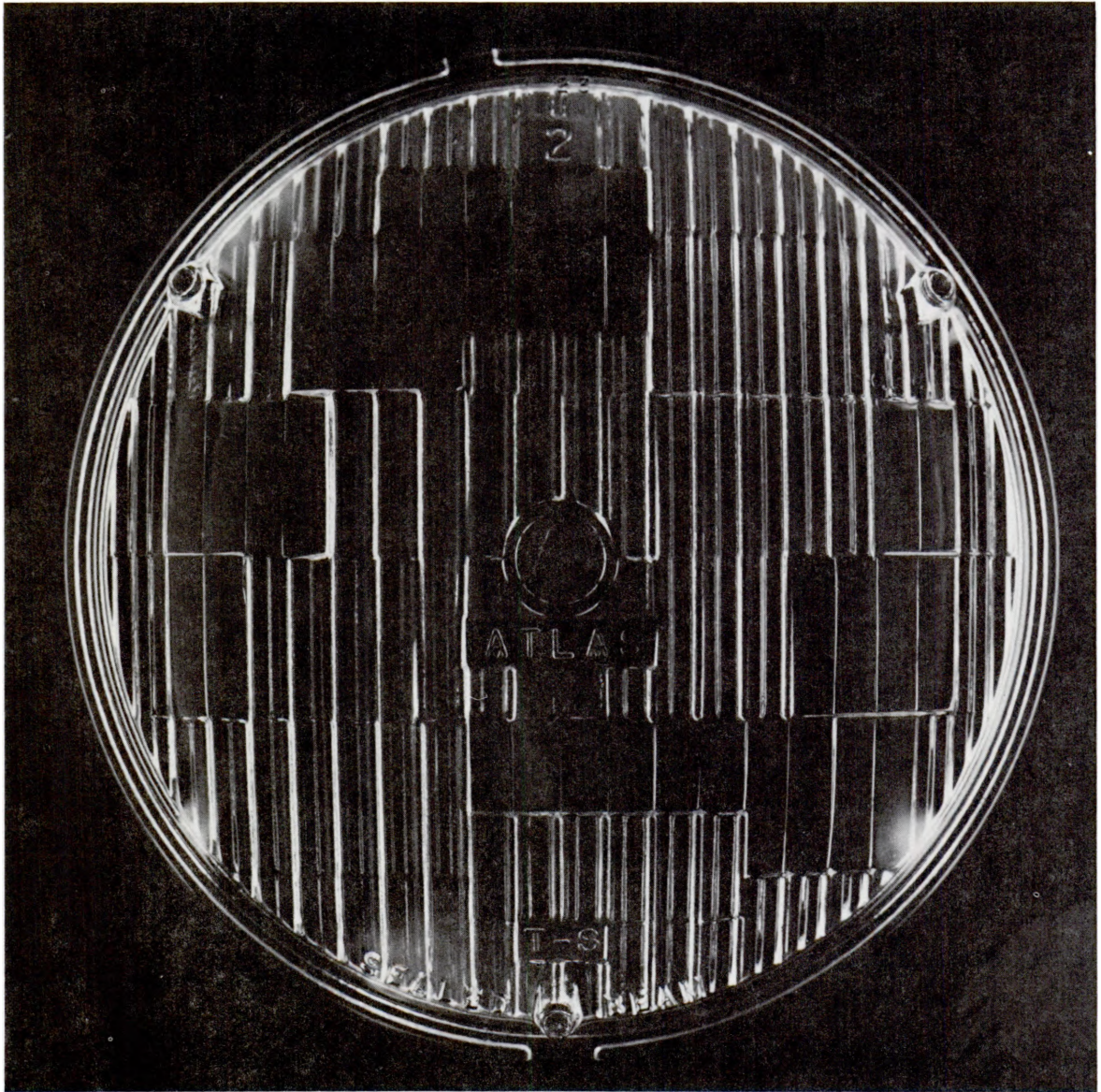

FIGURE A57. *Atlas/Tung-Sol, Type 2.*

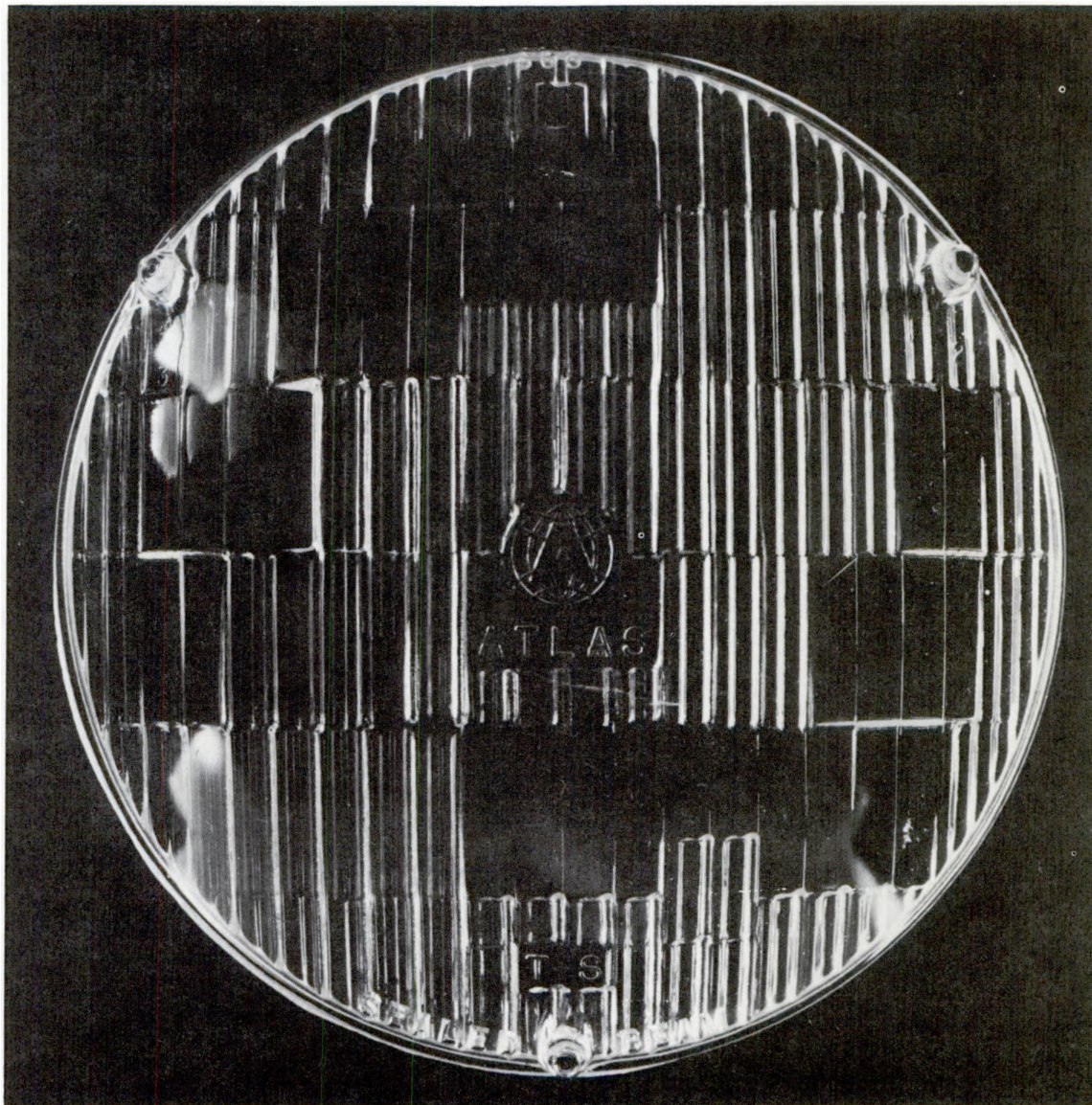

FIGURE A58. *Atlas/Tung-Sol, Type 2.*

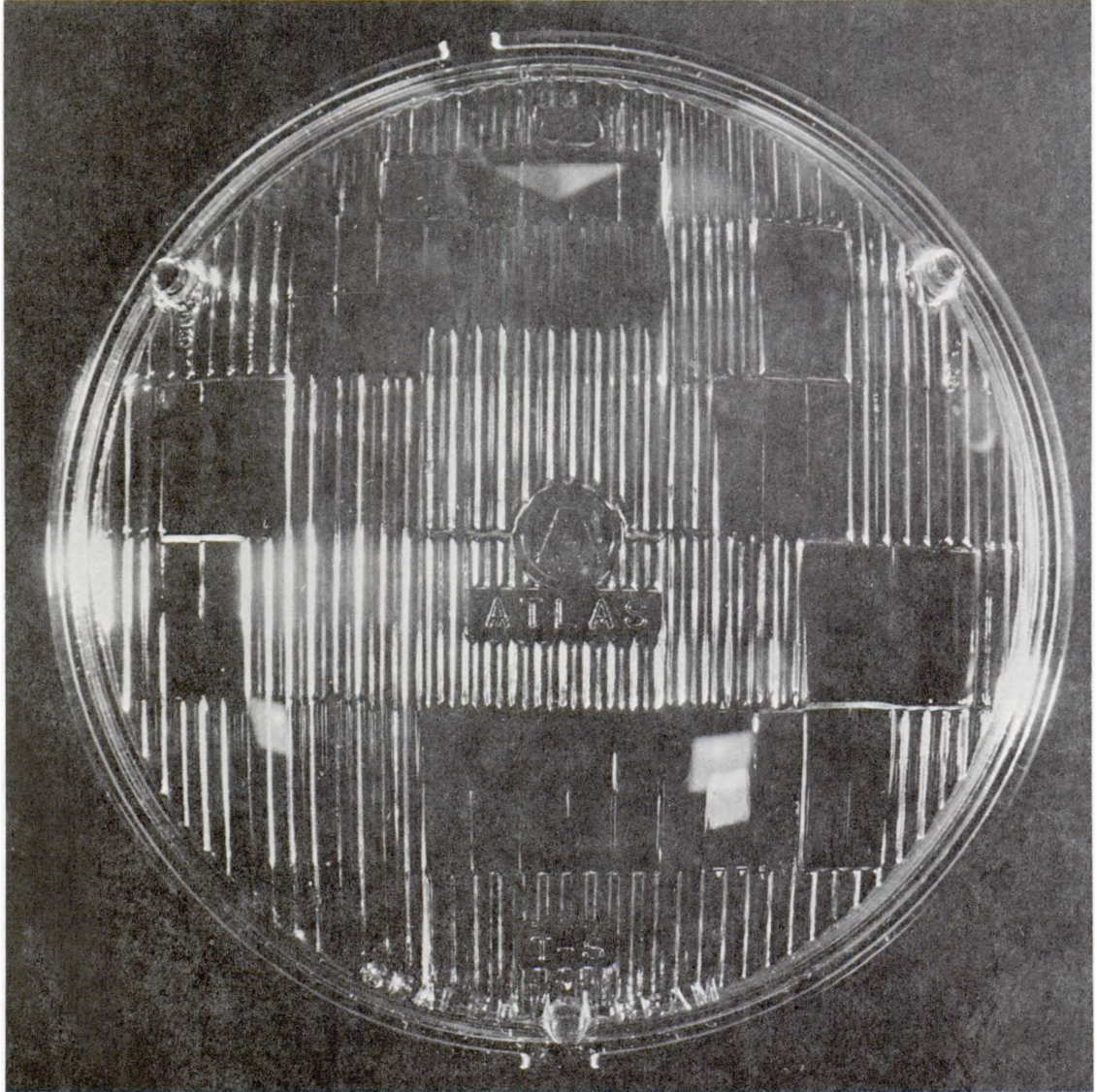

FIGURE A59. *Atlas/Tung-Sol, Type 2.*

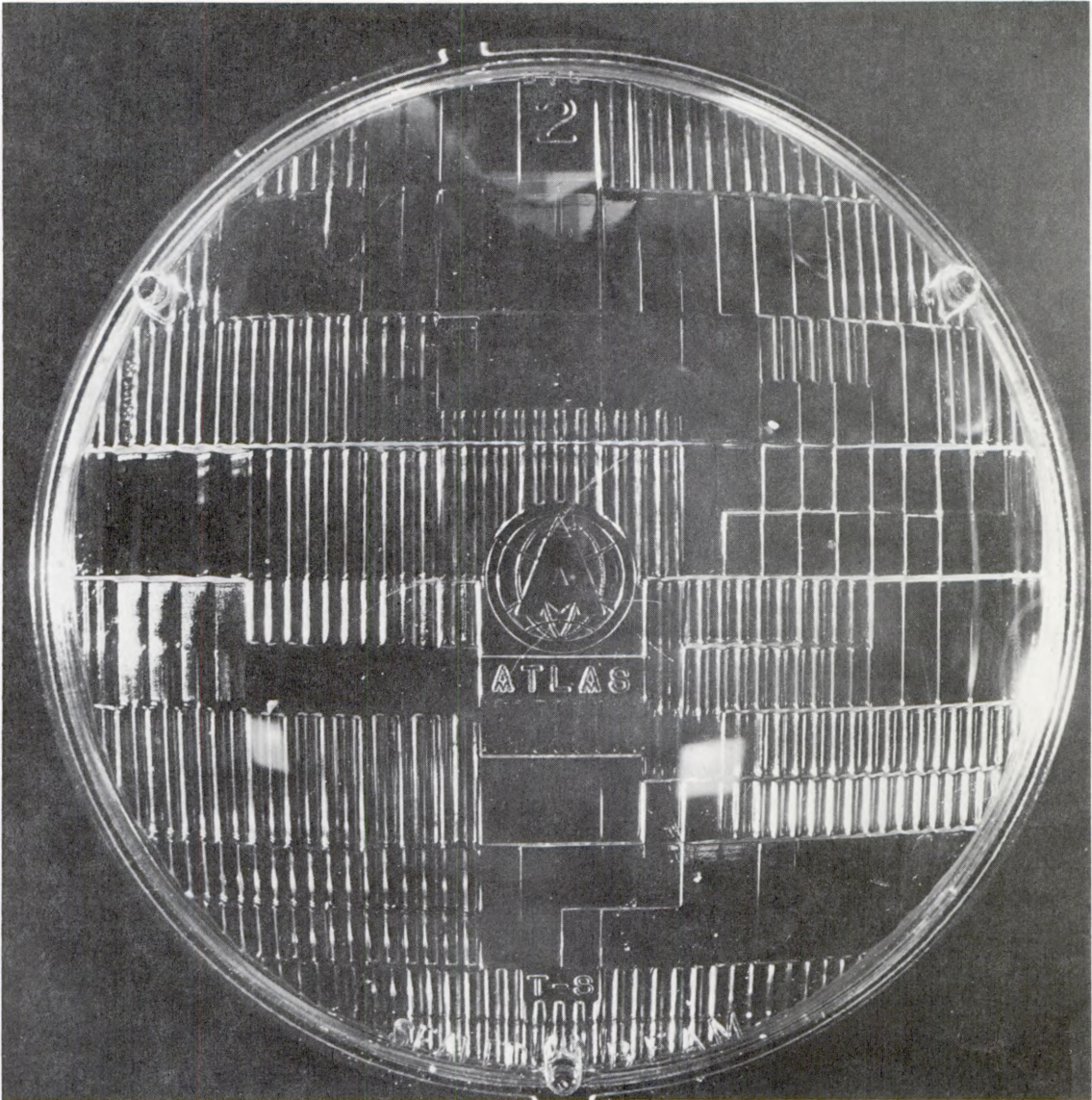

FIGURE A60. *Atlas/Tung-Sol, Type 2, Twin-Beam.*

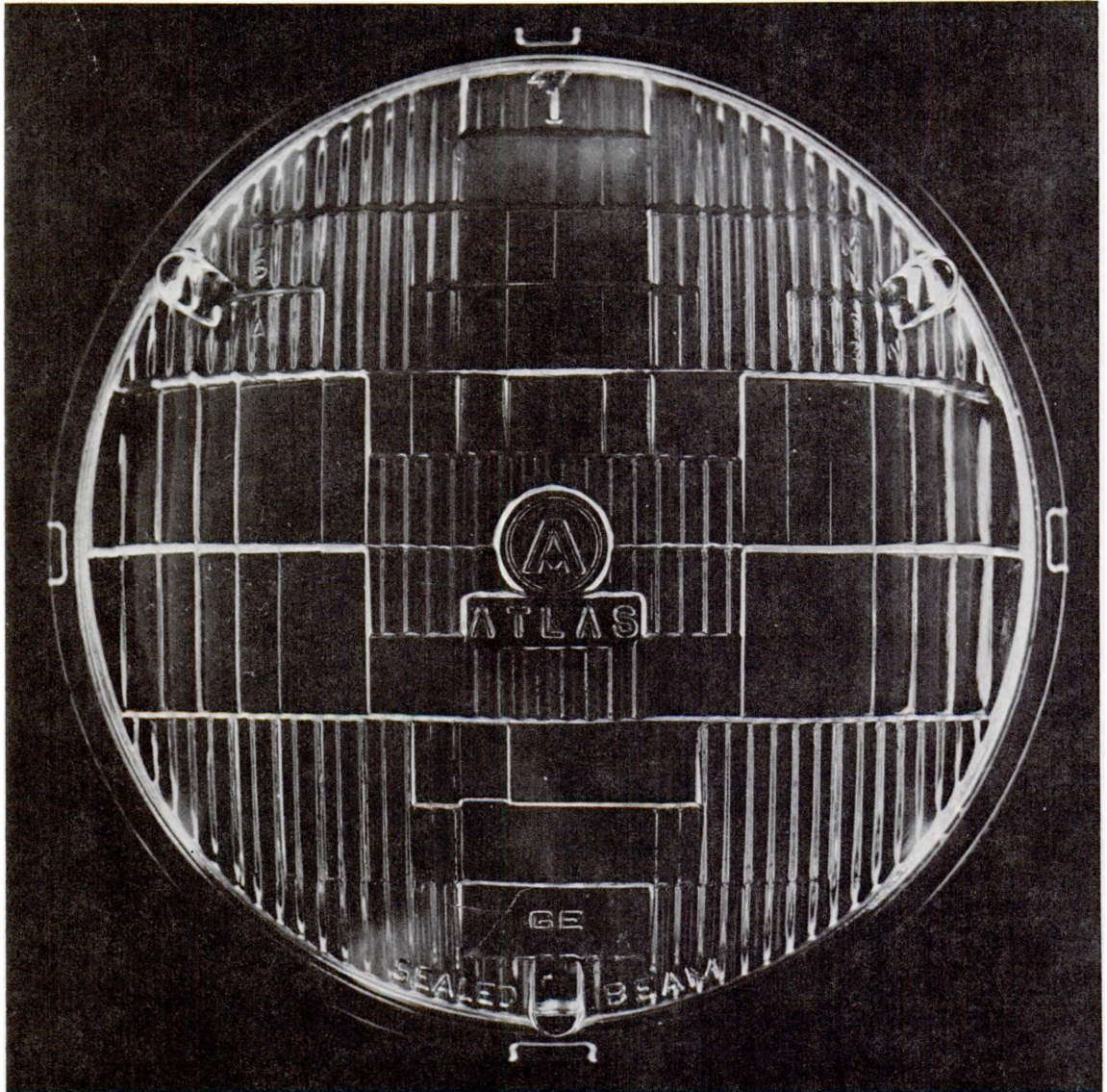

FIGURE A61. *Atlas/GE, Type 1.*

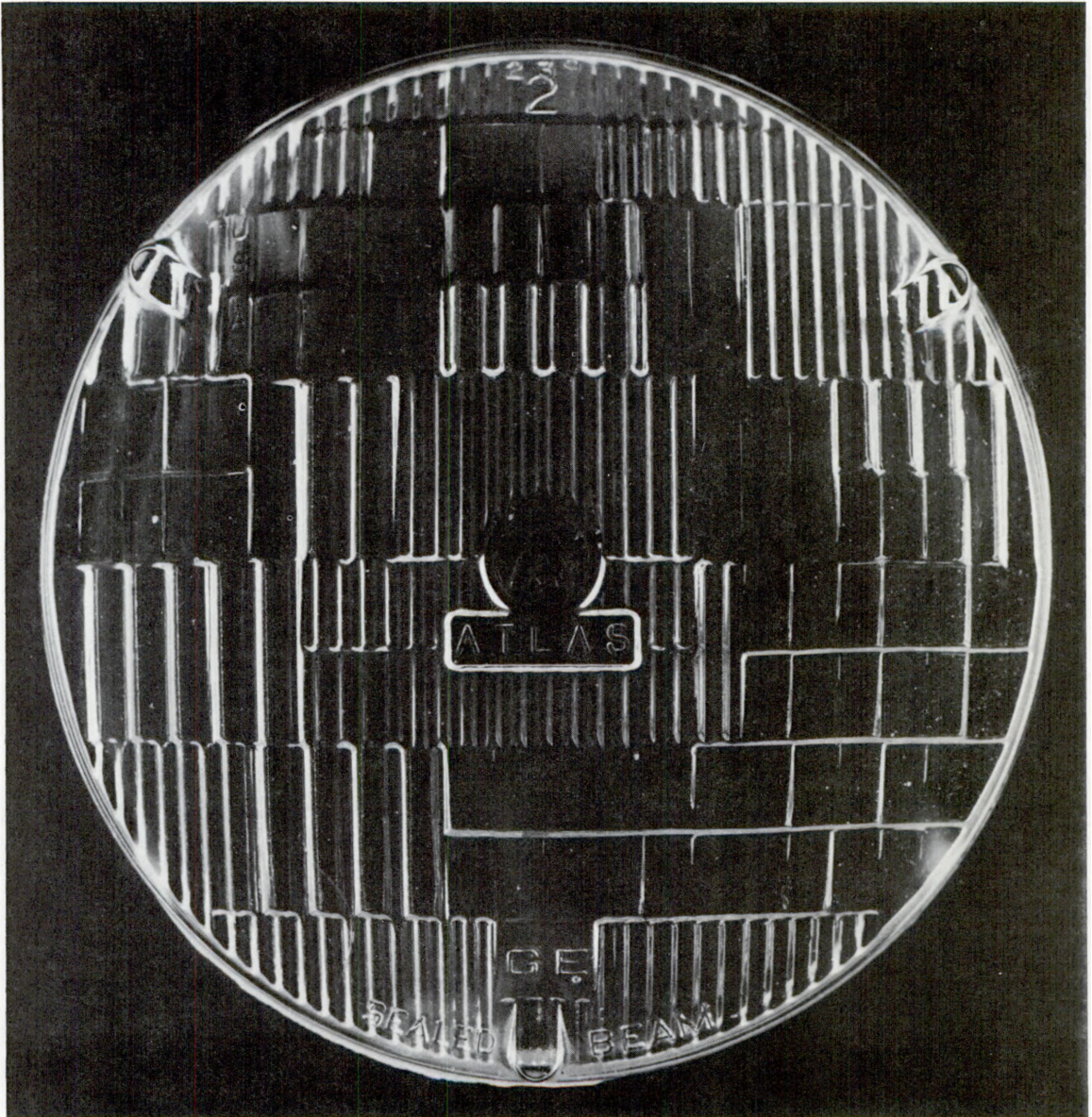

FIGURE A62. *Atlas/GE, Type 2.*

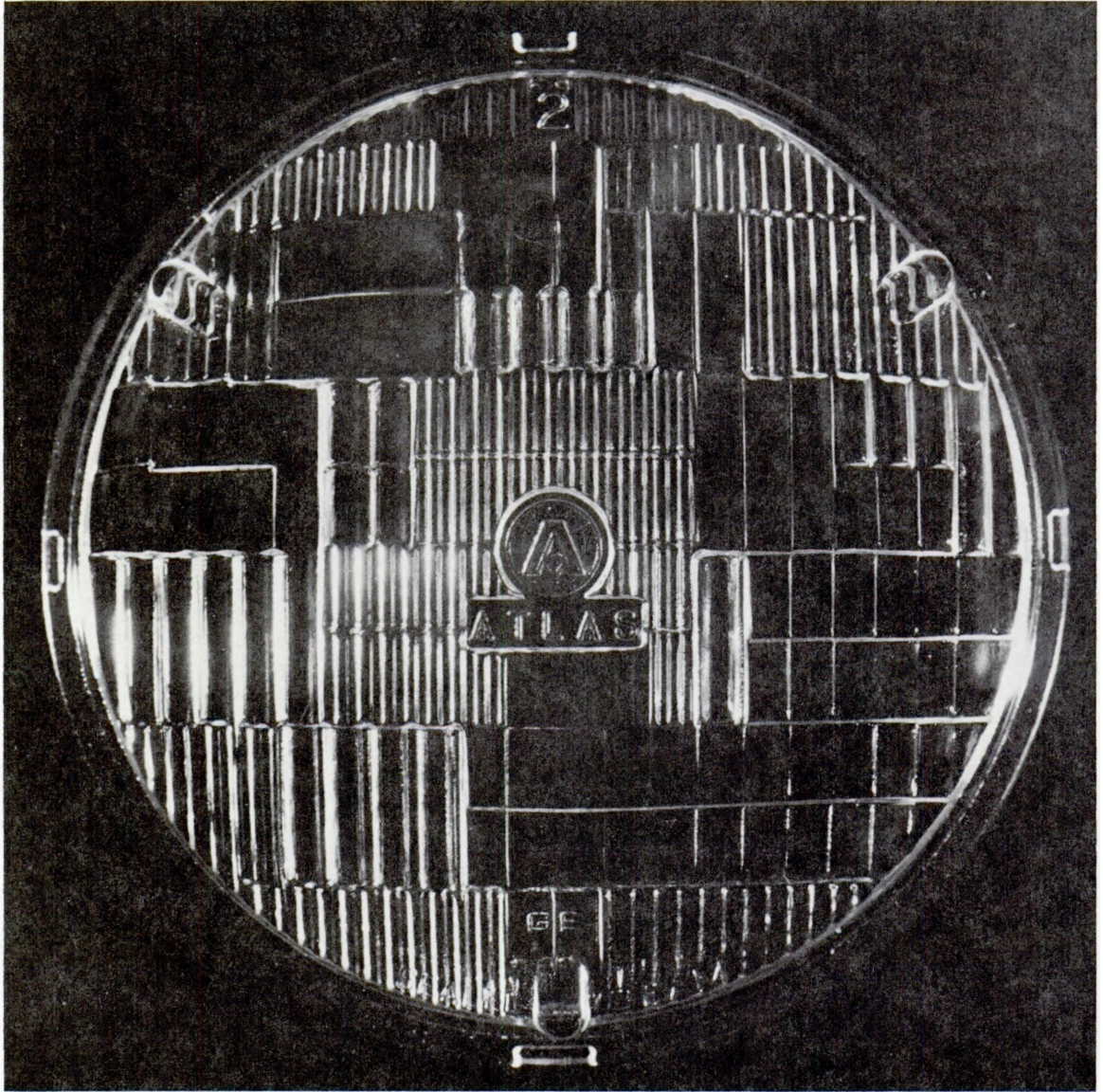

FIGURE A63. *Atlas/GE, Type 2.*

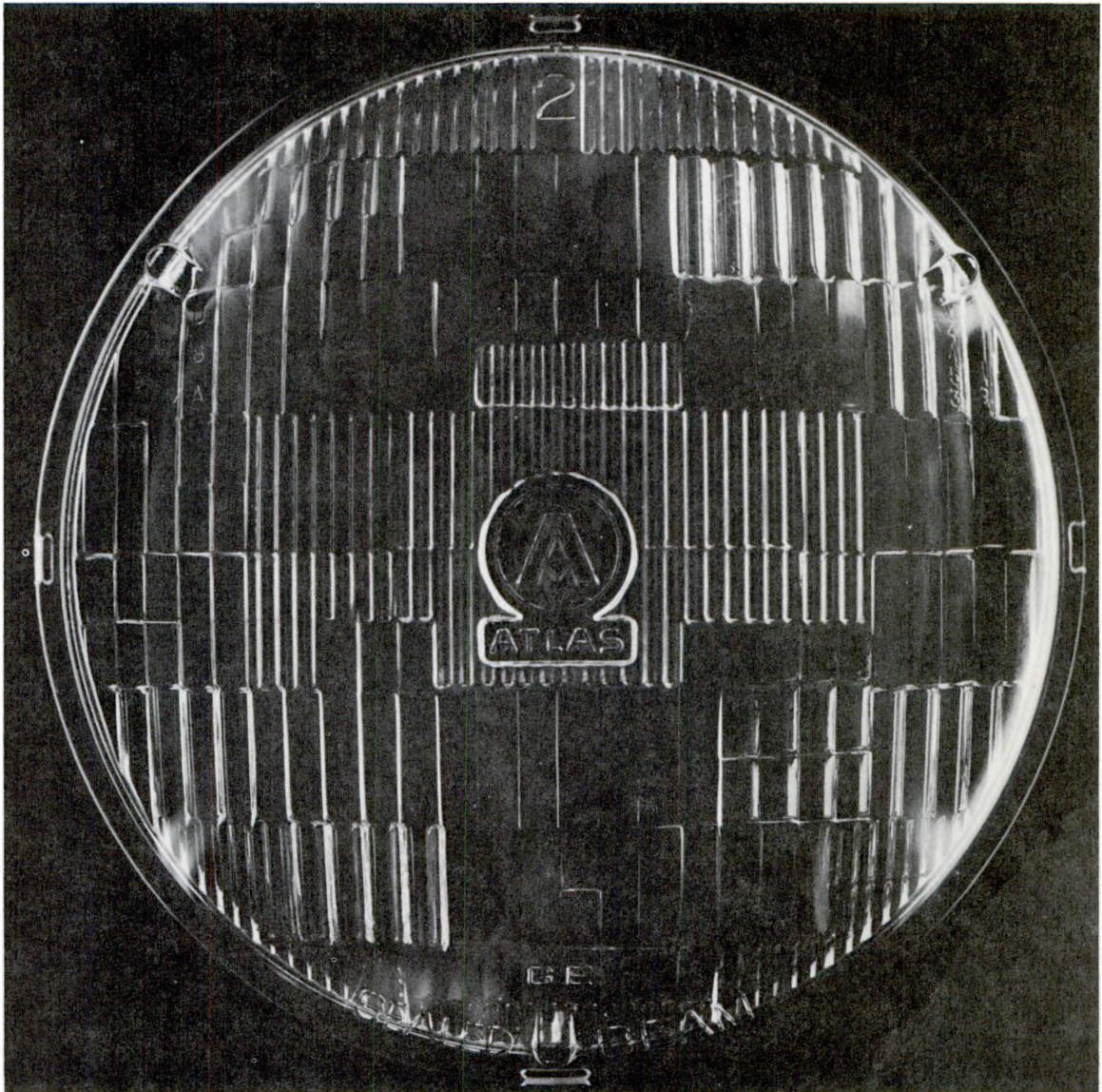

FIGURE A64. *Atlas/GE, Type 2, Twin-Beam.*

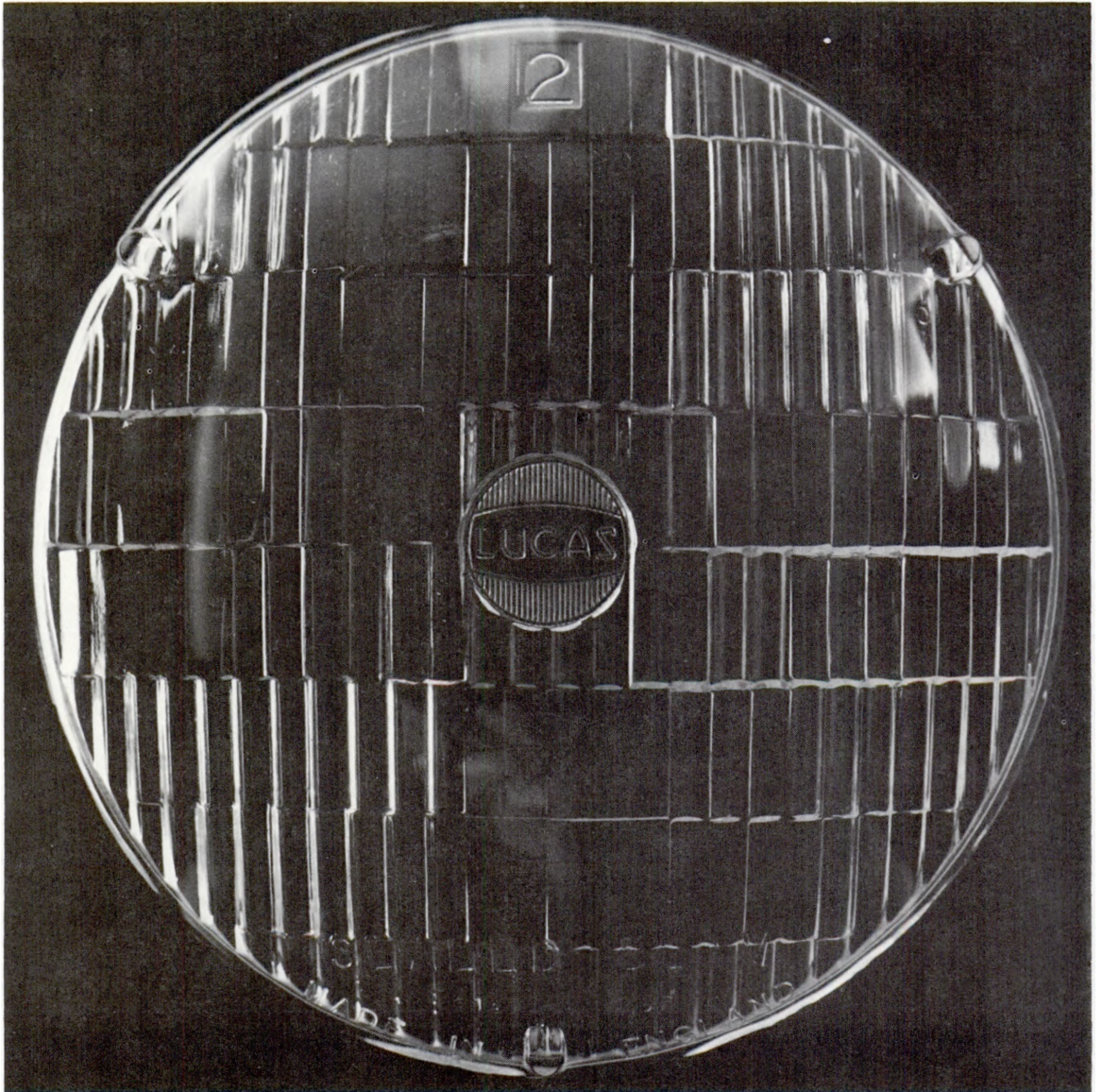

FIGURE A65. *Lucas, Type 2, Twin-Beam.*

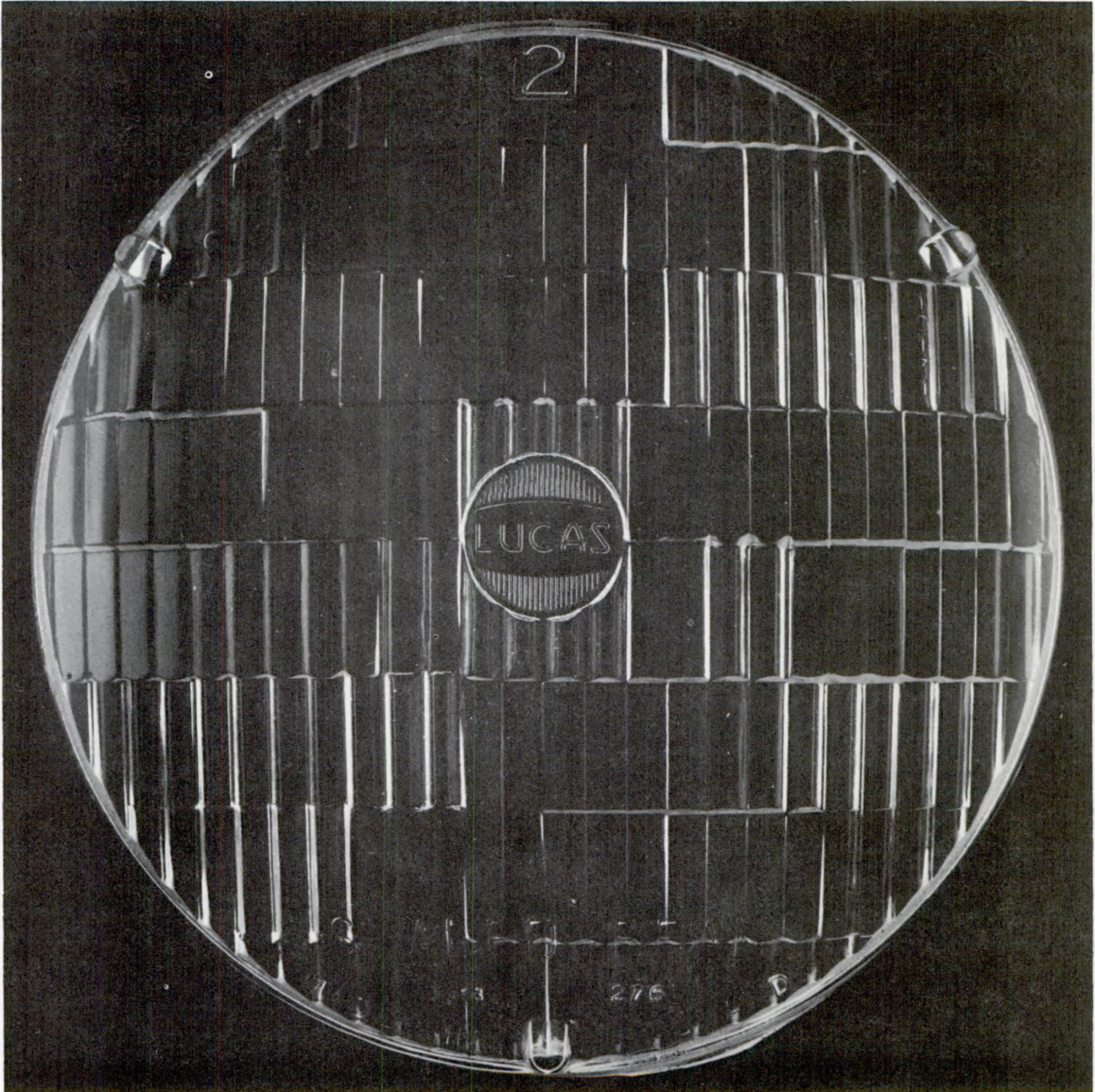

FIGURE A66. *Lucas, Type 2, Twin-Beam.*

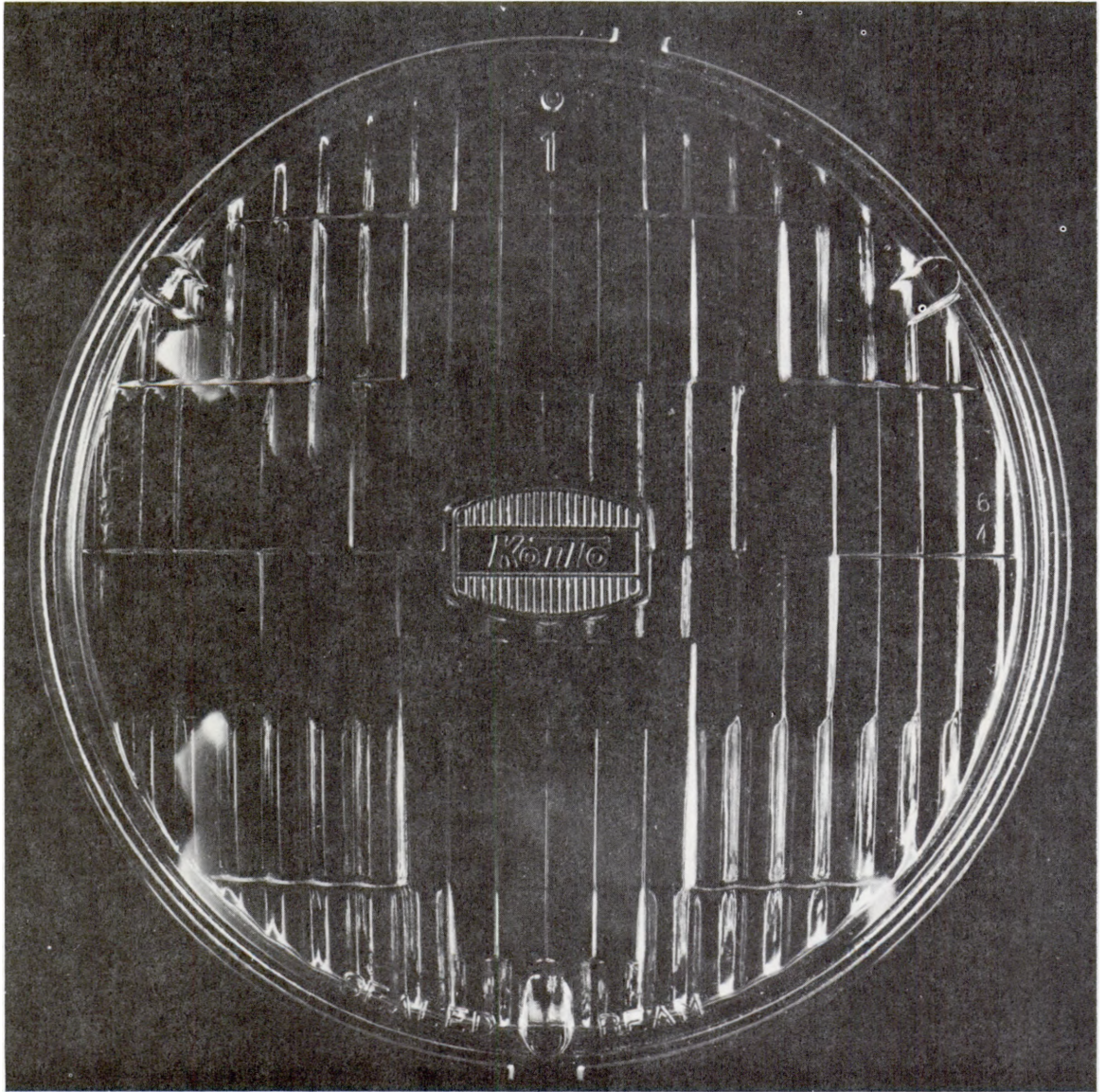

FIGURE A67. *Koito, Type 1.*



FIGURE A68. *Koito, Type 2.*

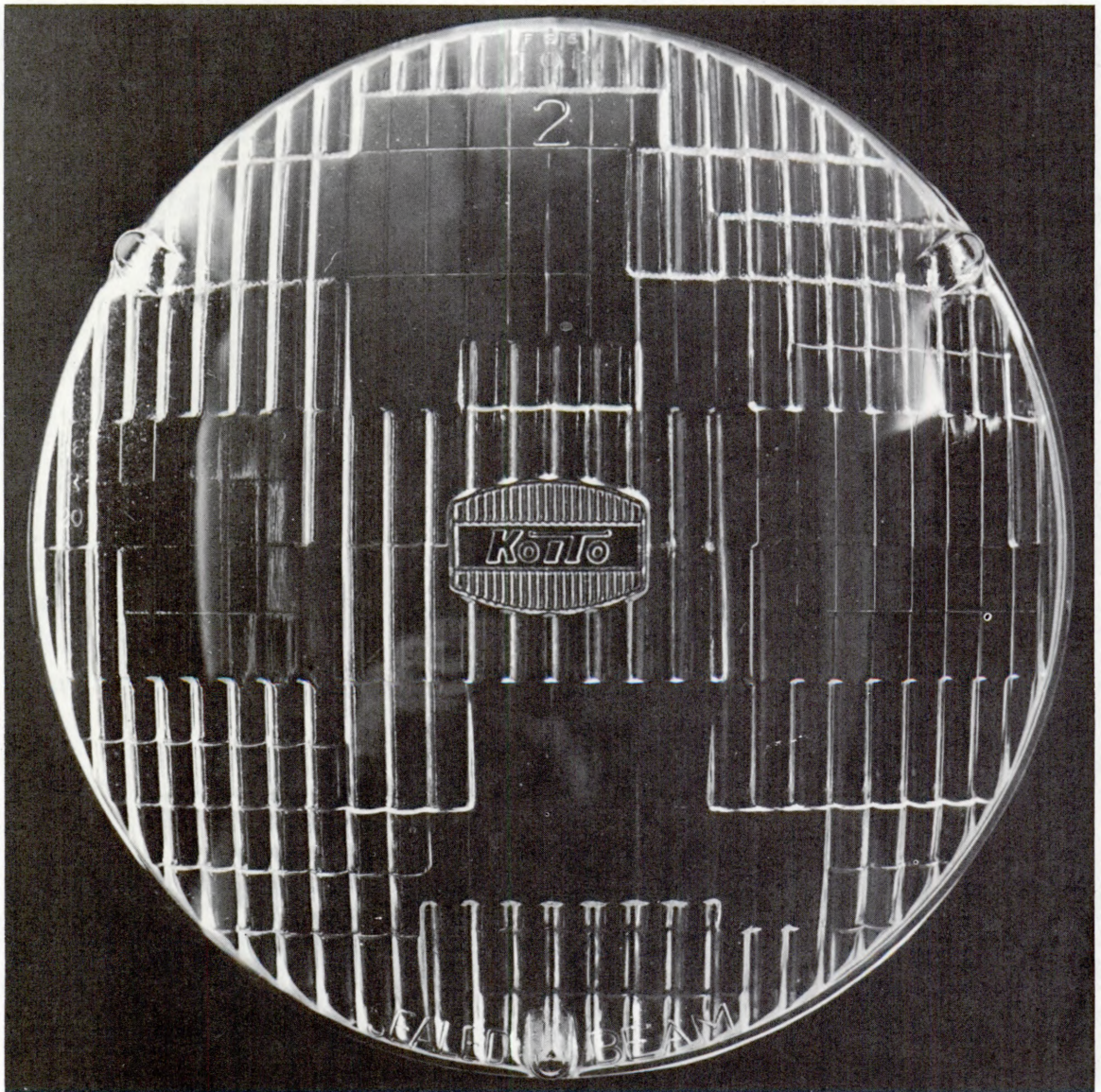

FIGURE A69. *Koito, Type 2, Twin-Beam.*

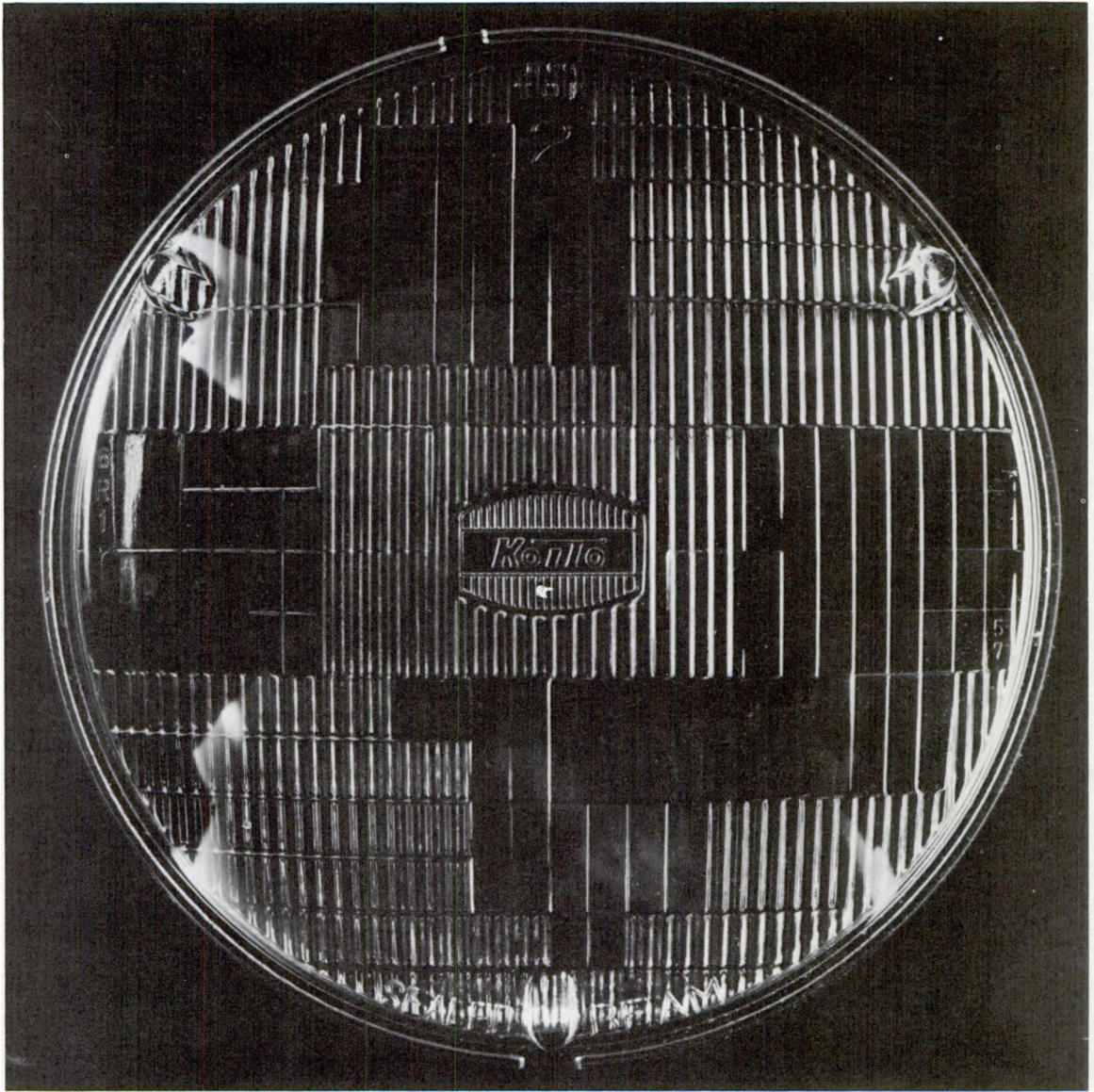

FIGURE A70. *Koito, Type 2, Twin-Beam.*

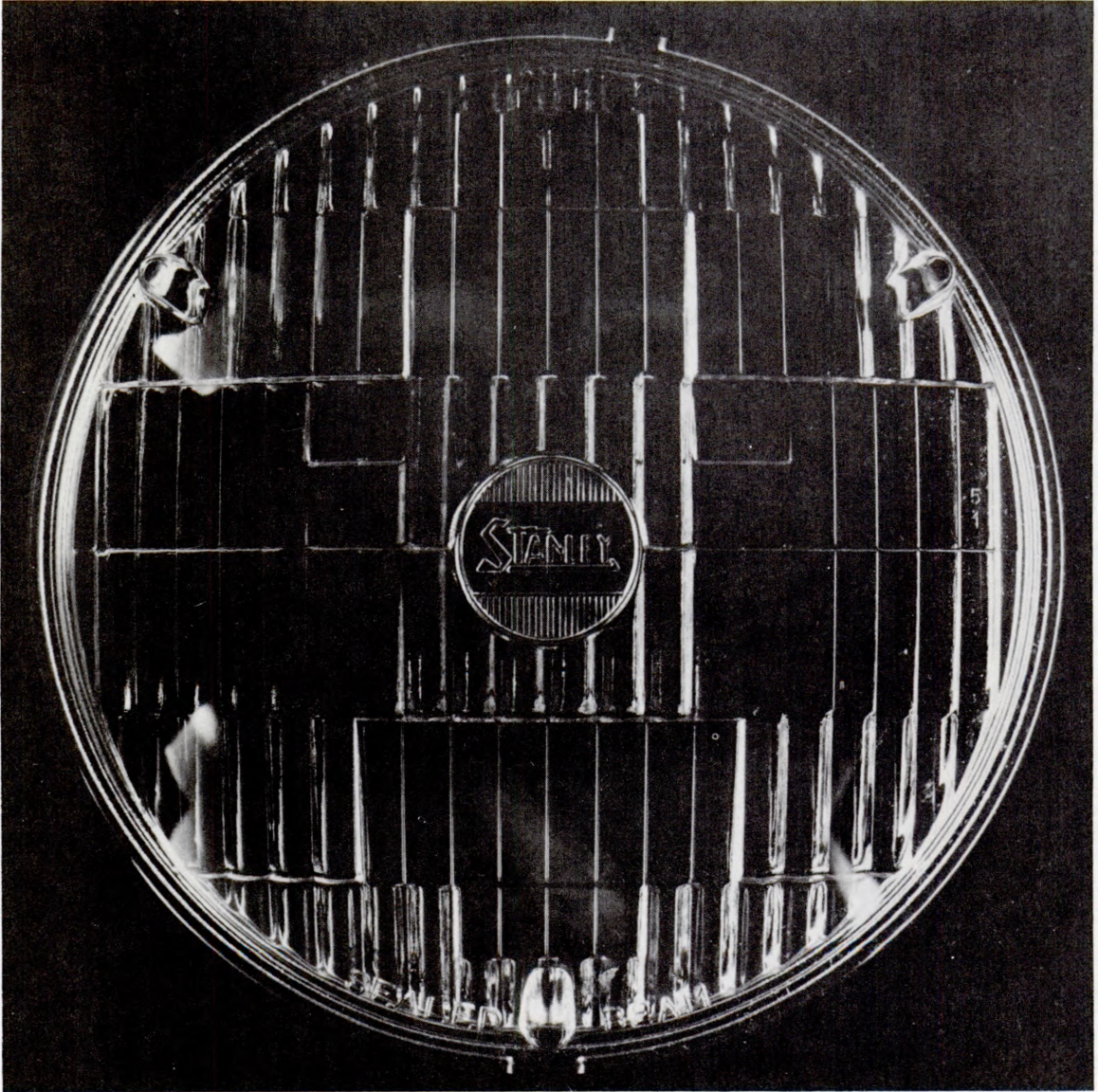

FIGURE A71. *Stanley, Type 1.*

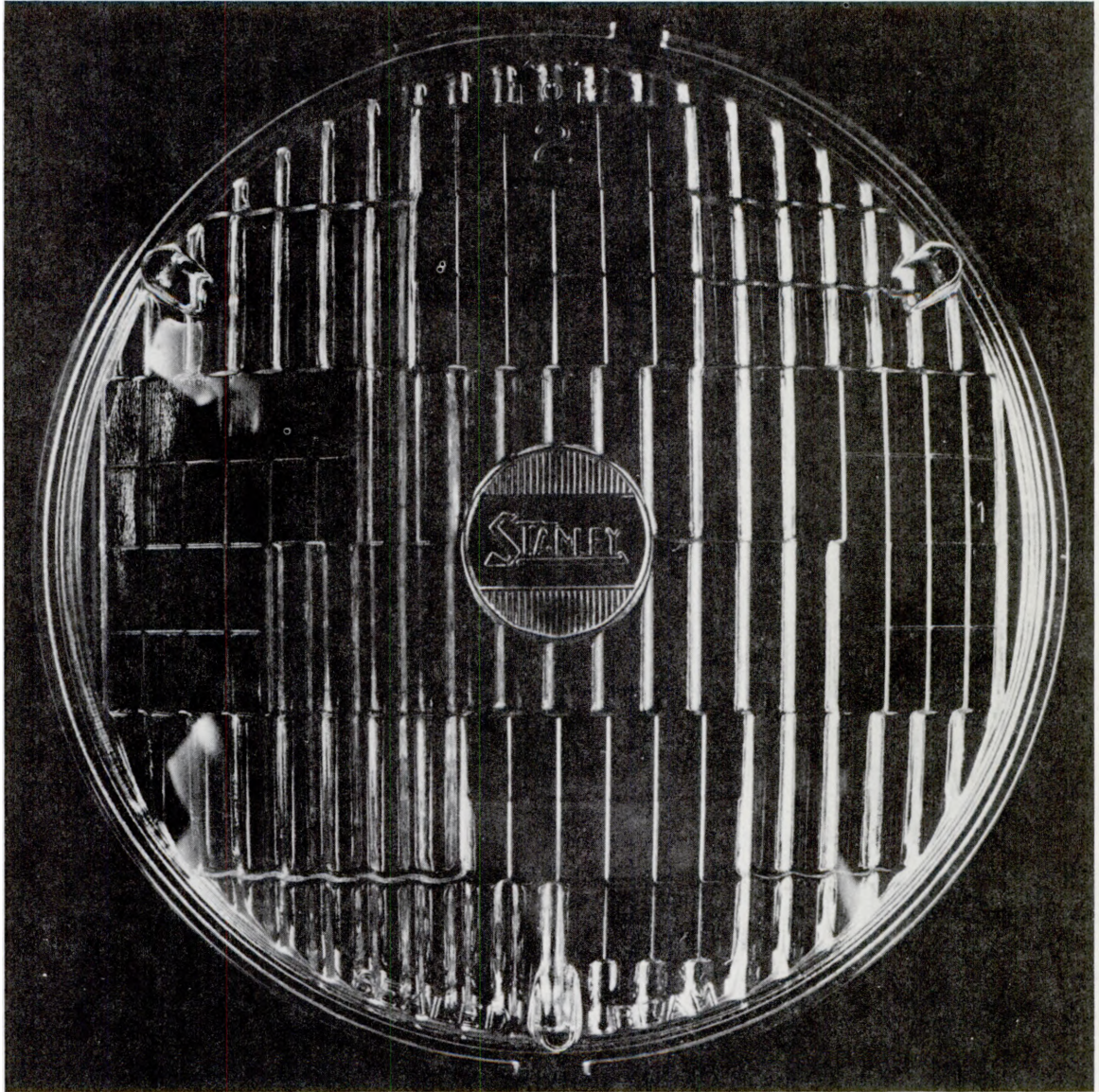

FIGURE A72. *Stanley, Type 2.*

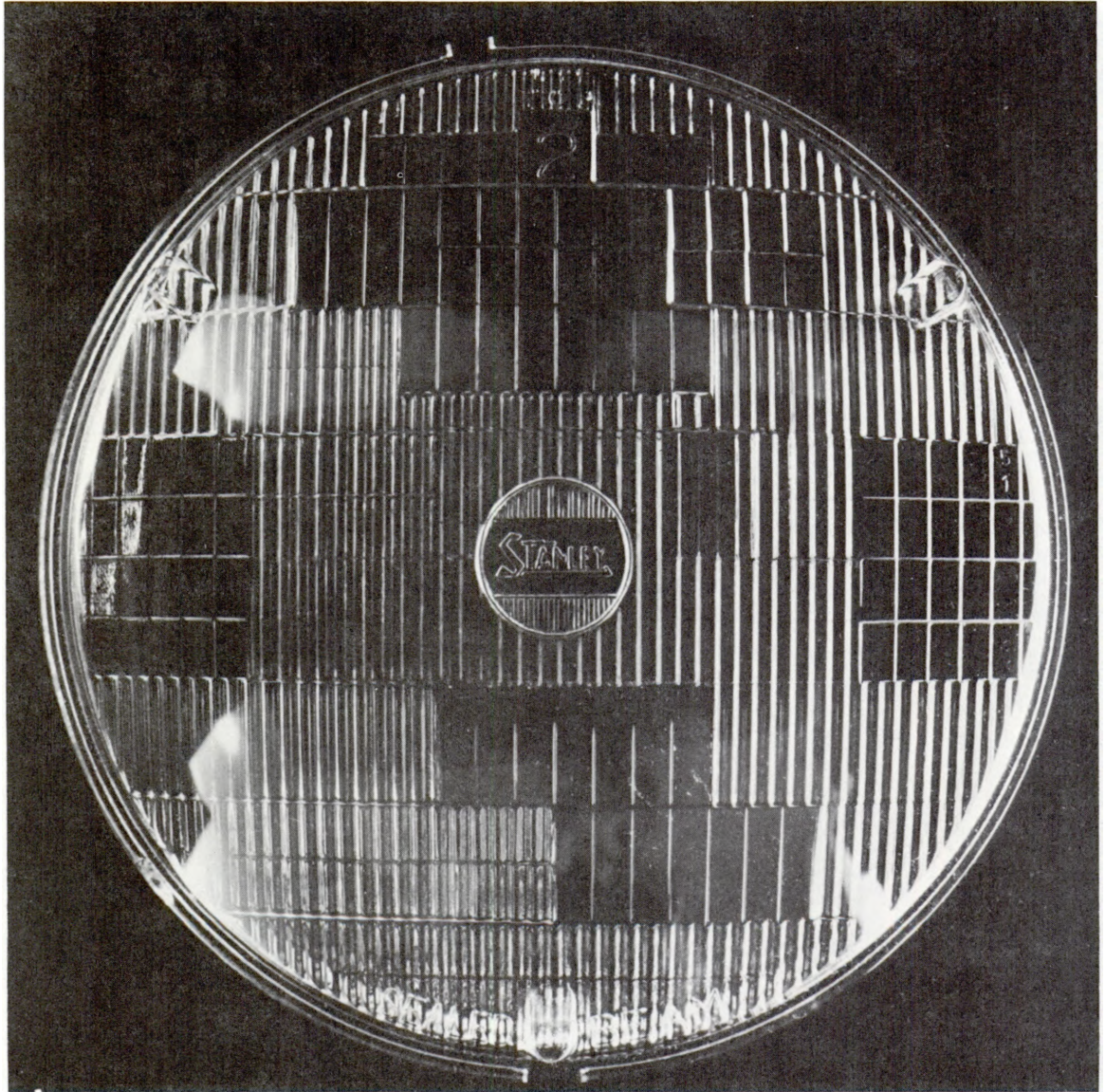

FIGURE A73. *Stanley, Type 2, Twin-Beam.*

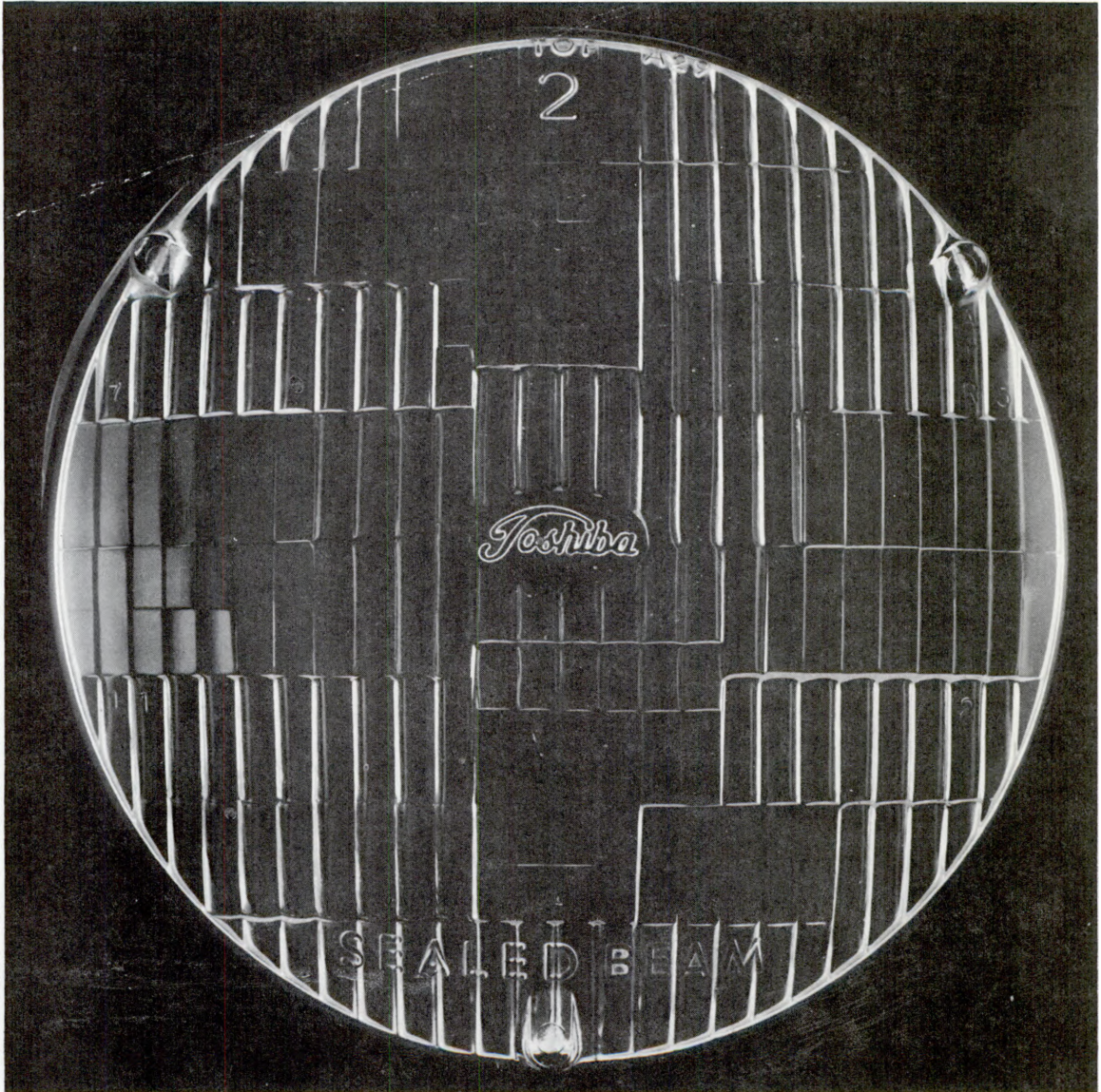

FIGURE A74. *Toshiba, Type 2, Twin-Beam.*

Appendix B—Selected Illustrations of Westinghouse Headlight Lenses

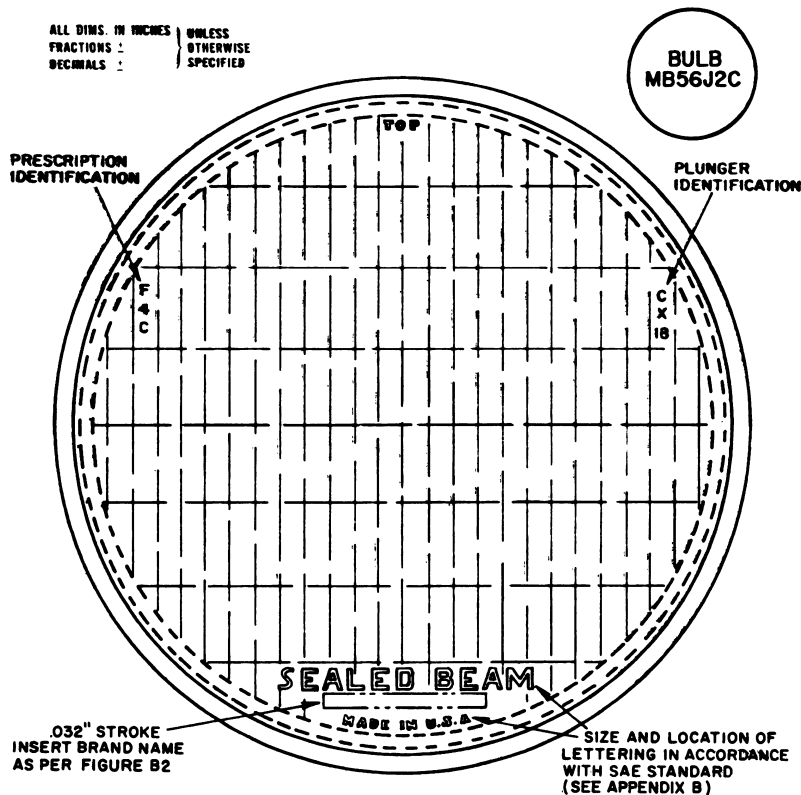

FIGURE B1. *Westinghouse 5040 lamp design.*

Westinghouse 5040 lamps used in this pattern in 1955. The possible inserts are shown in figure B2.

Insert 1 WESTINGHOUSE

Insert 2 HALL LAMP

ALL DIMS. IN INCHES } UNLESS
FRACTIONS ± } OTHERWISE
DECIMALS ± } SPECIFIED

Insert 3 FoMoCo

FIGURE B2. *Inserts relevant to 1955 Westinghouse 5040 and 5400 lens patterns.*

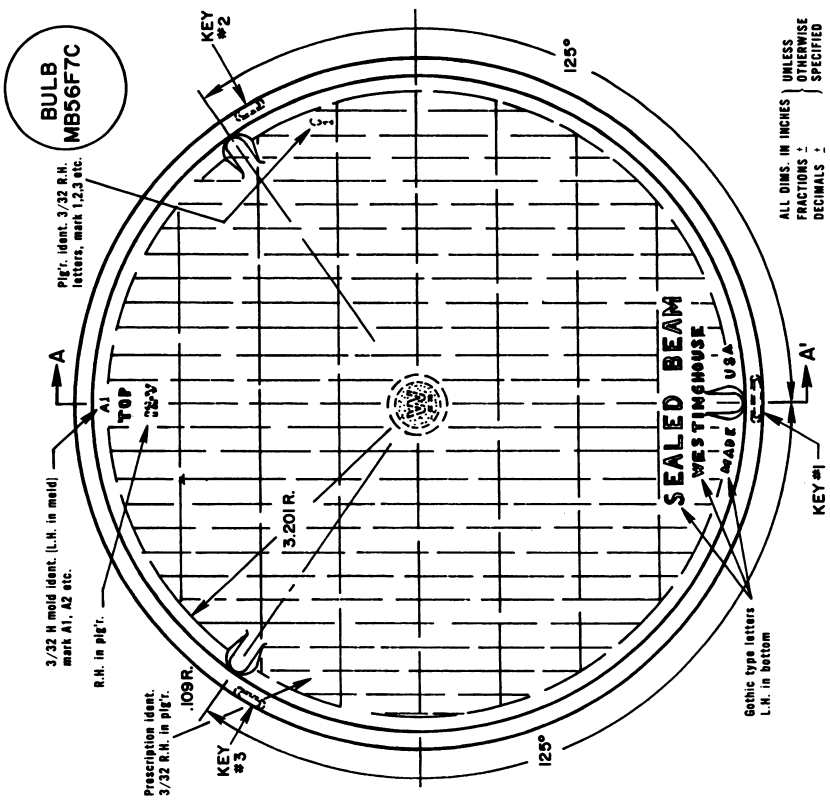

FIGURE B4. *Westinghouse 5400 lamp design.*
 This general layout (fluting pattern not detailed here) * was used from 1956 into 1958 on 5400 lamps.
 * This, essentially means that the fluting pattern contains flutes $\frac{1}{8}$ " wide.

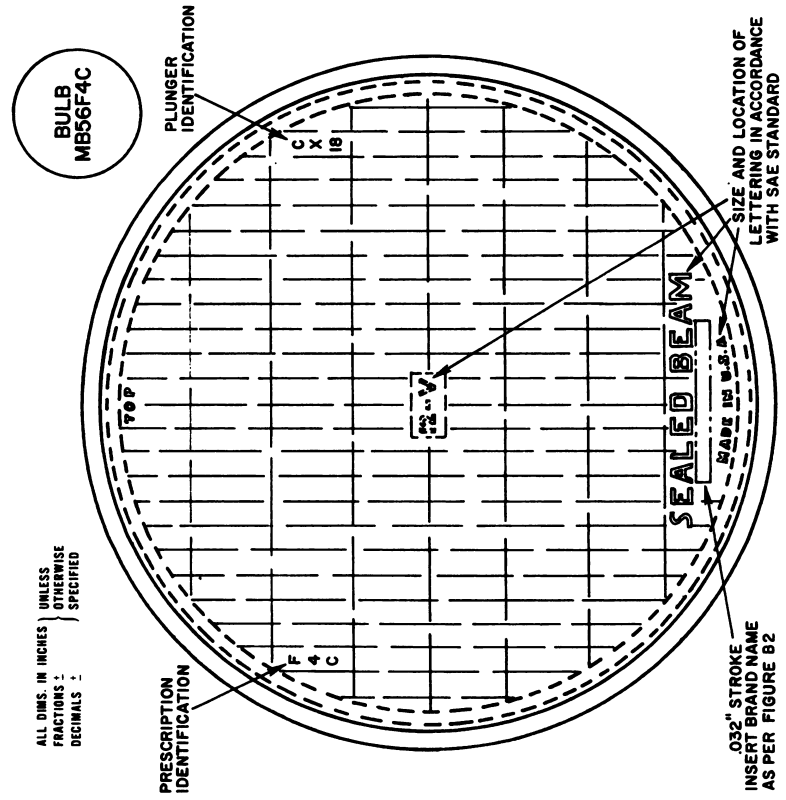

FIGURE B3. *Westinghouse 5400 lamp design.*
 5400 lamps used this pattern in 1955. The possible inserts are shown in figure B2.

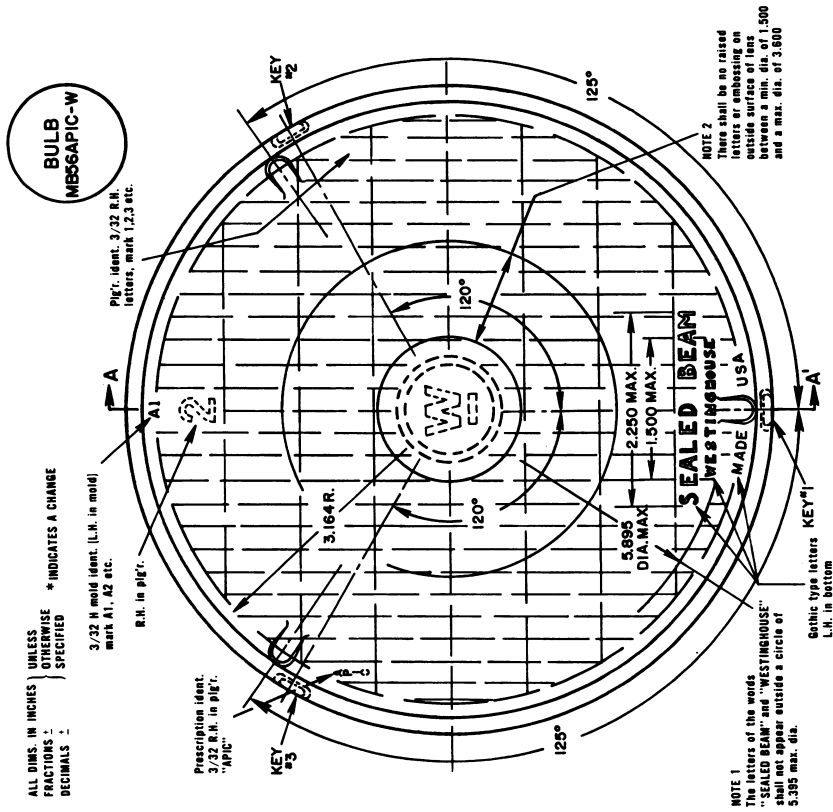

FIGURE B6. *Westinghouse 6012 lamp design.* This general lens design (fluting pattern not detailed) was used on Westinghouse 6006 and 6012 lamps from about February 1958 to June 1959. A detailed drawing of the center monogram is found in figure 3d.

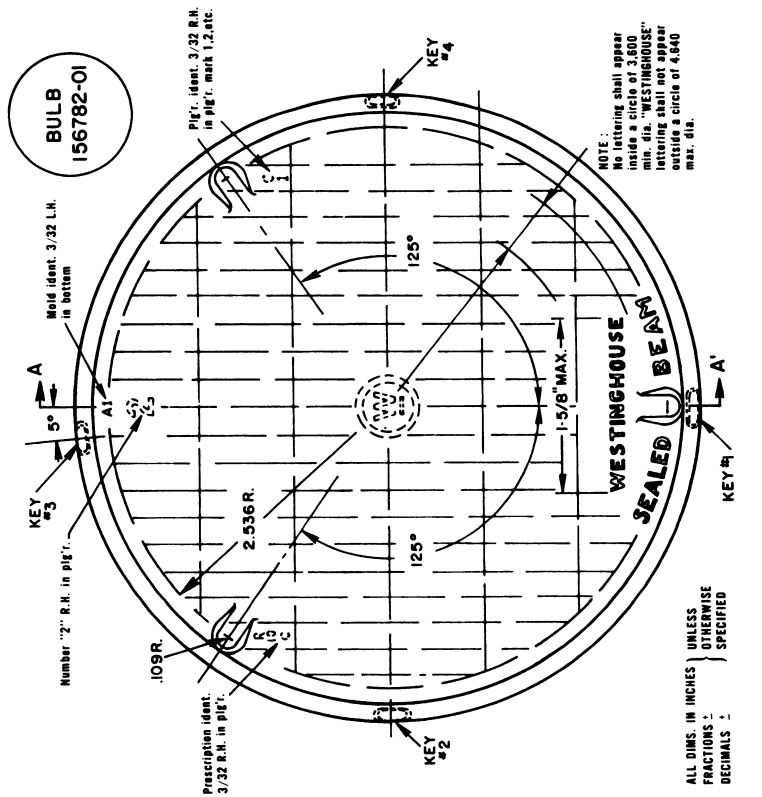

FIGURE B5. *Westinghouse 4002 lamp design.* This lens design (fluting detail omitted) was used on Westinghouse 4002, and probably 4001 lamps from about September 1960 to April 1962. A detailed drawing of the center monogram may be found in figure 3b.

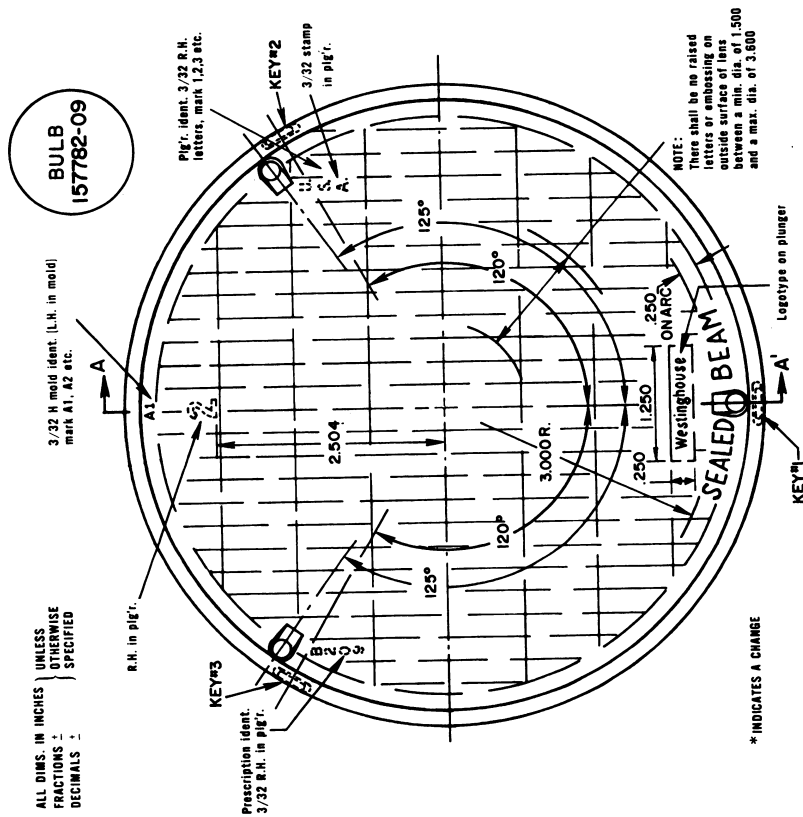

FIGURE B7. *Westinghouse 6012 lamp design.* This general lamp design (fluting pattern is not detailed) with the Westinghouse logo at the bottom of lens, but above the words "sealed beam," was used in 6006 and 6012 lamps since 1962 and in 6014 lamps since 1969.

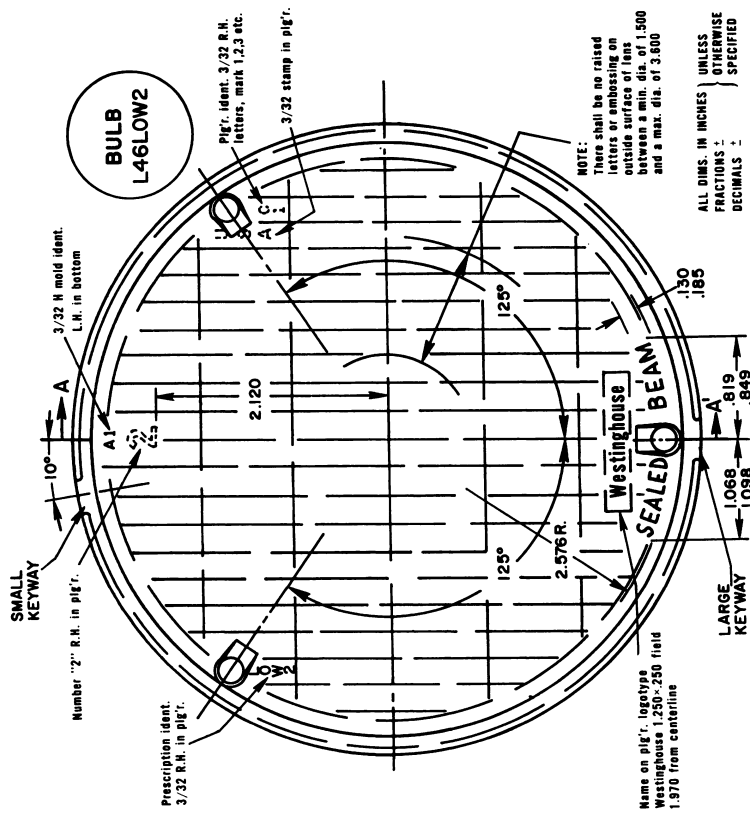
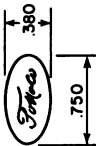

FIGURE B8. *Westinghouse 4002 lamp design.* This general lamp design (fluting detail omitted) is typical of Westinghouse 4002/4000 and 4001 (except for the numeral near the top of the lens) lamps since about April 1962.

This lens is identical with lens 156781-04 except as shown below

FOMOCO TRADEMARK
SIZE NO. 4 ON PLS'R.



BULB
156781-71

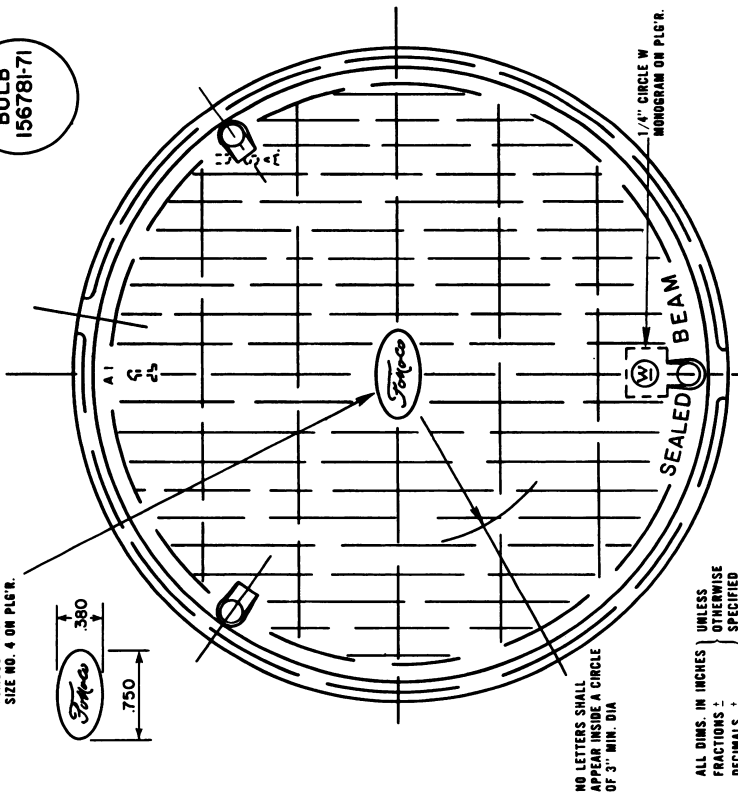

This lens is identical with lens #146H1G1 except as shown below

NOTE:
SPREAD FLUTES ARE FOLDED
DOUBLE RADIUS*

INNER CIRCLE 1/2" DIA.

*
BULB
L46AT1

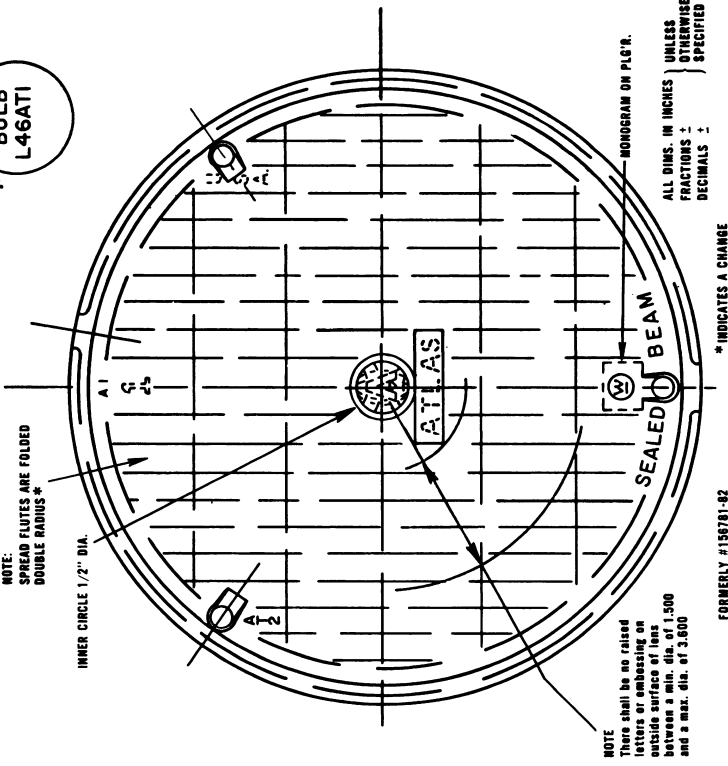

NOTE
There shall be no raised
letters or embossing on
outside surface of lens
between a min. dia. of 1.500
and a max. dia. of 3.600

ALL DIMS. IN INCHES
FRACTIONS ± UNLESS
OTHERWISE
DECIMALS ± SPECIFIED

FIGURE B9. Westinghouse 4001 lamp made for the Ford Motor Company (FoMoCo).
This general layout (fluting pattern omitted) was used on "FoMoCo" 4001 and 4002 lamps, assembled by Westinghouse from June 1962 to 1969.

FIGURE B10. Westinghouse 4001 lamp made for Atlas Mfg. Co.
This general layout (fluting pattern omitted) was used on Atlas 4001 and 4002 lamps, assembled by Westinghouse, since about 1962 and in 5001 lamp since 1972.

This lens is identical with lens *L56LW2 except as shown below

ALL DIMS. IN INCHES) UNLESS
 FRACTIONS ±) OTHERWISE
 DECIMALS ±) SPECIFIED

* INDICATES A CHANGE *

BULB
 L56AT2

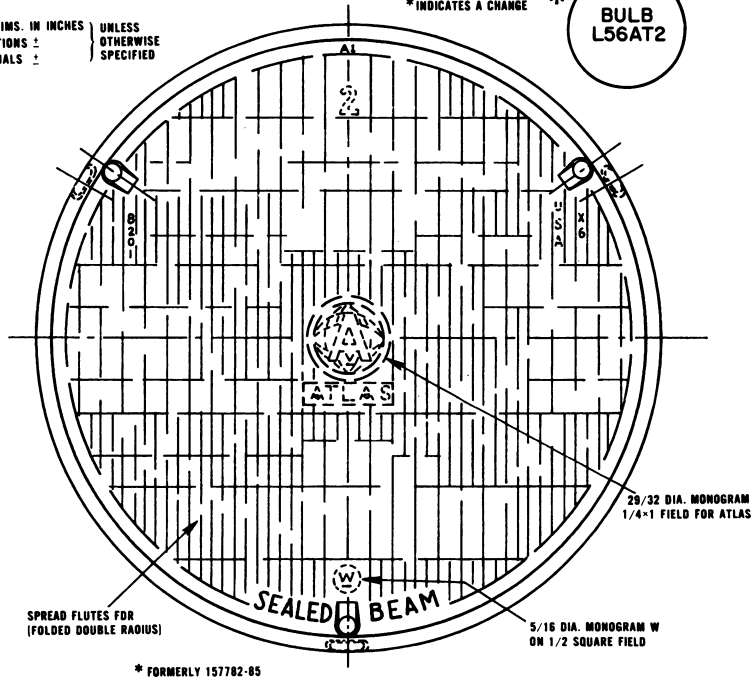

FIGURE B11. *Westinghouse 6006 lamp made for Atlas Mfg. Co.*

This general layout (fluting pattern omitted) had been used on Atlas 6006, 6012 and 6014 lamps, assembled by Westinghouse, since about 1962.

WESTINGHOUSE ELECTRIC CORPORATION
LAMP DIVISION
SPECIFICATION

SPEC. NO. *156782-01 Pg.1
DATE Sep. 28, 1960
SUPERSEDES MB46R12C-W Pg.1
DATED 5/15/59

BULB
156782-01

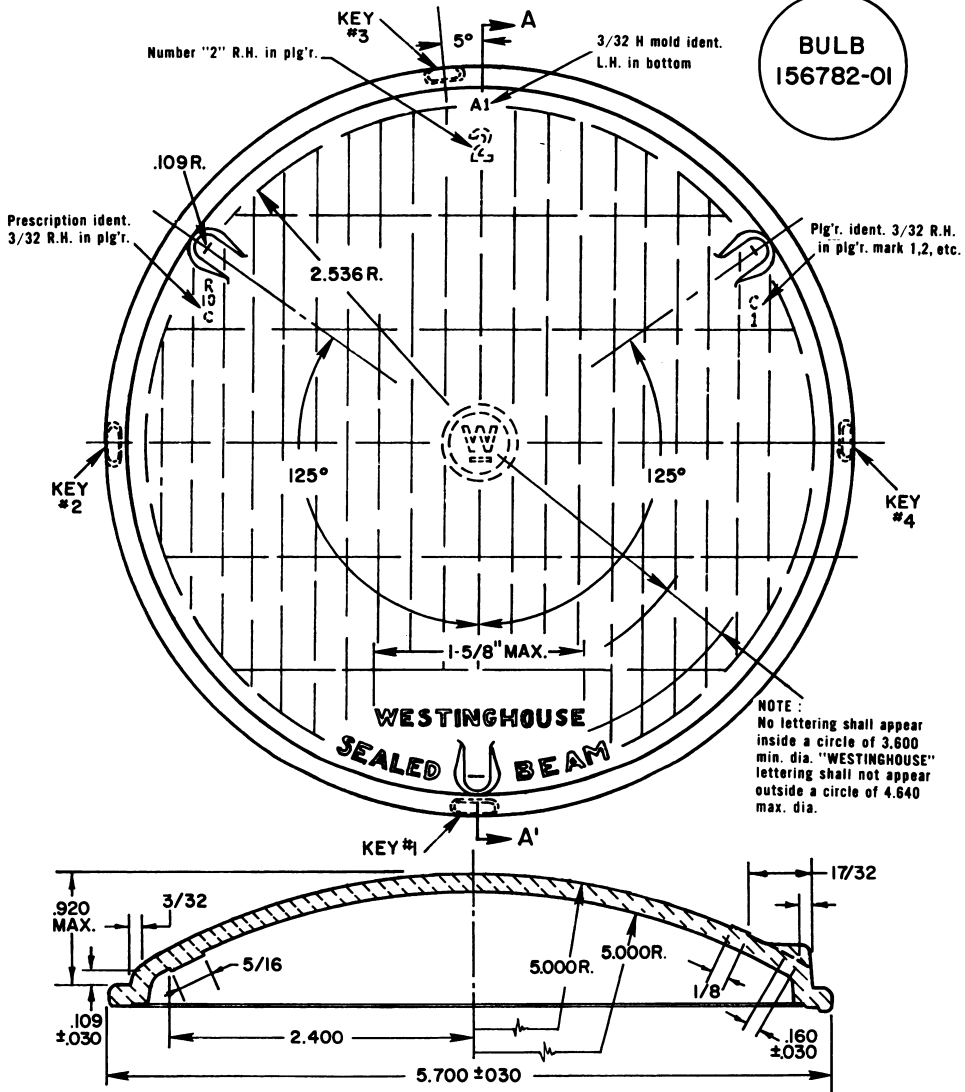

NOTE:
No lettering shall appear
inside a circle of 3.600
min. dia. "WESTINGHOUSE"
lettering shall not appear
outside a circle of 4.640
max. dia.

ALL DIMS. IN INCHES } UNLESS OTHERWISE SPECIFIED
FRACTIONS ± }
DECIMALS ± } * INDICATES A CHANGE

FIGURE B12. *Westinghouse 4002 lamp lens design.*
This general design was used from 1960 until April 1962.

WESTINGHOUSE ELECTRIC CORPORATION
LAMP DIVISION
SPECIFICATION

SPEC. NO. 156782-01 Pg.2
DATE Sep. 28, 1960
SUPERSEDES MB46R12C-W Pg.2
DATED 5/15/59

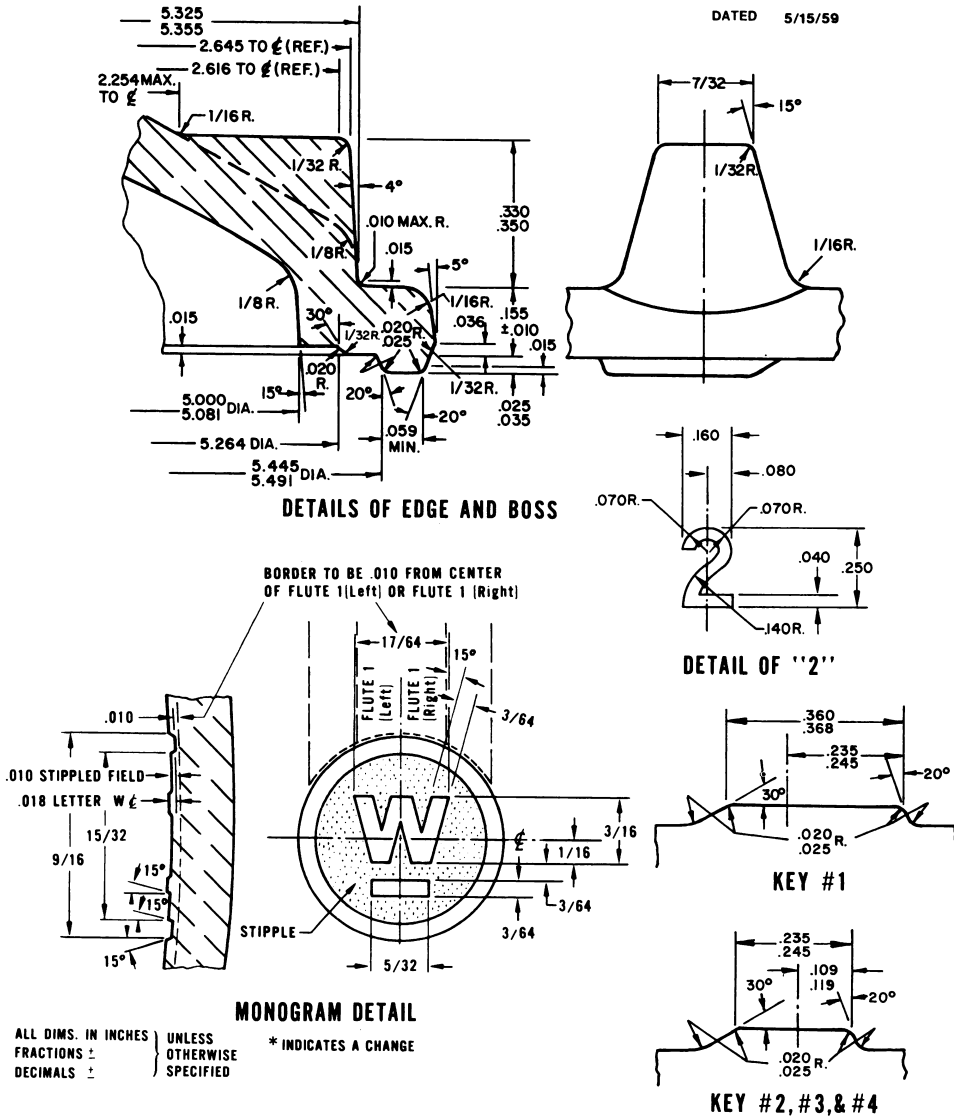

FIGURE B13. *Westinghouse 4002 lamp lens detail.*
These specifications were valid to at least 1962.

WESTINGHOUSE ELECTRIC CORPORATION
LAMP DIVISION
SPECIFICATION

SPEC. NO. 156782-04 Pg. 1

DATE Apr. 27, 1962

SUPERSEDES 156782-01 Pg.1

DATED 9/28/60

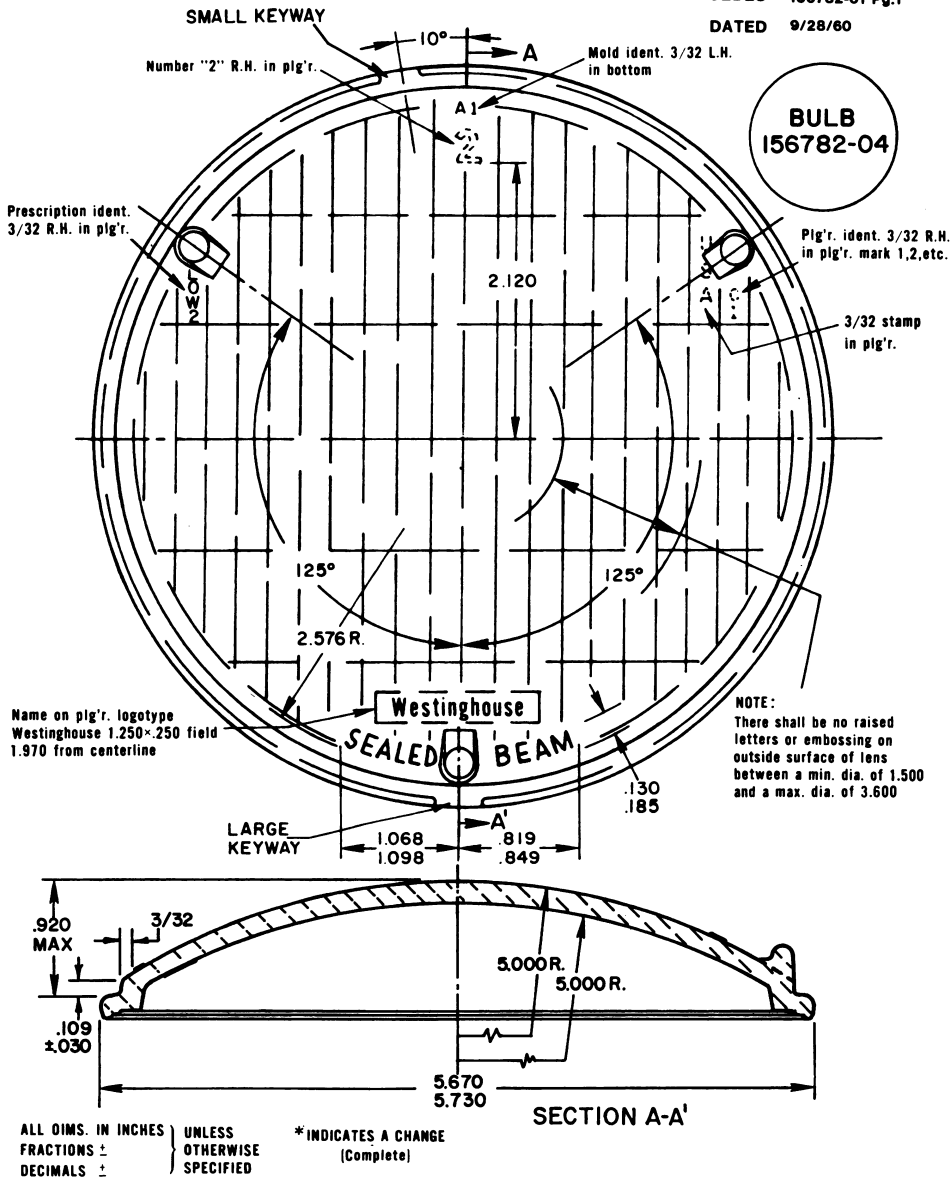
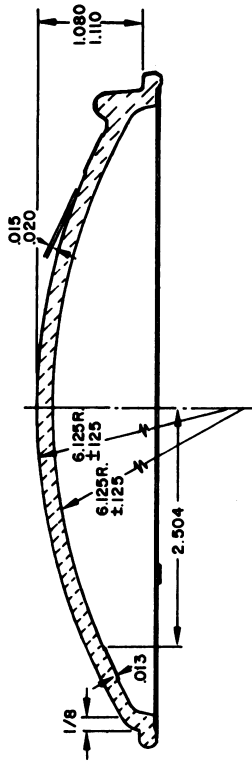

FIGURE B14. *Westinghouse 4002 lamp lens design.*

This general design was used from April 1962 until 1971 (see fig. 2a for clarification).

WESTINGHOUSE ELECTRIC CORPORATION SPEC. NO. 'L56LOW2 Pg. 2
LAMP DIVISION DATE July 21, 1971
SUPERSEDES 157782-14 Pg. 2
SPECIFICATION DATED 2/19/66



SECTION A-A'

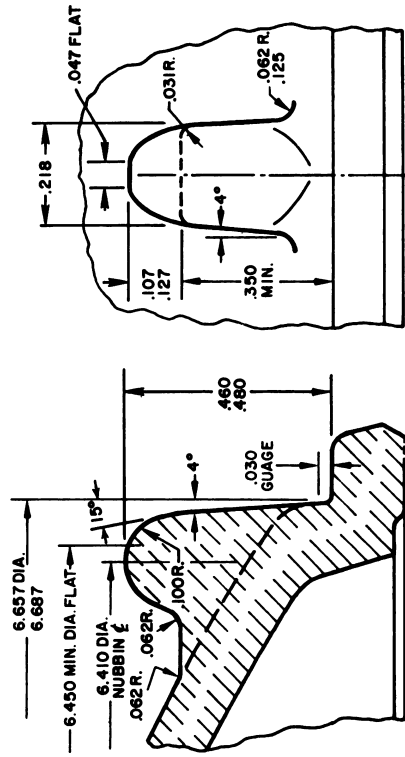

AIMING PAD DETAIL

* FORMERLY 157782-14

ALL DIMS. IN INCHES UNLESS OTHERWISE SPECIFIED
FRACTIONS ±
DECIMALS ±

* INDICATES A CHANGE

WESTINGHOUSE ELECTRIC CORPORATION SPEC. NO. 'L56LOW2 Pg. 1
LAMP DIVISION DATE July 21, 1971
SUPERSEDES 157782-14 Pg. 1
SPECIFICATION DATED 2/19/66

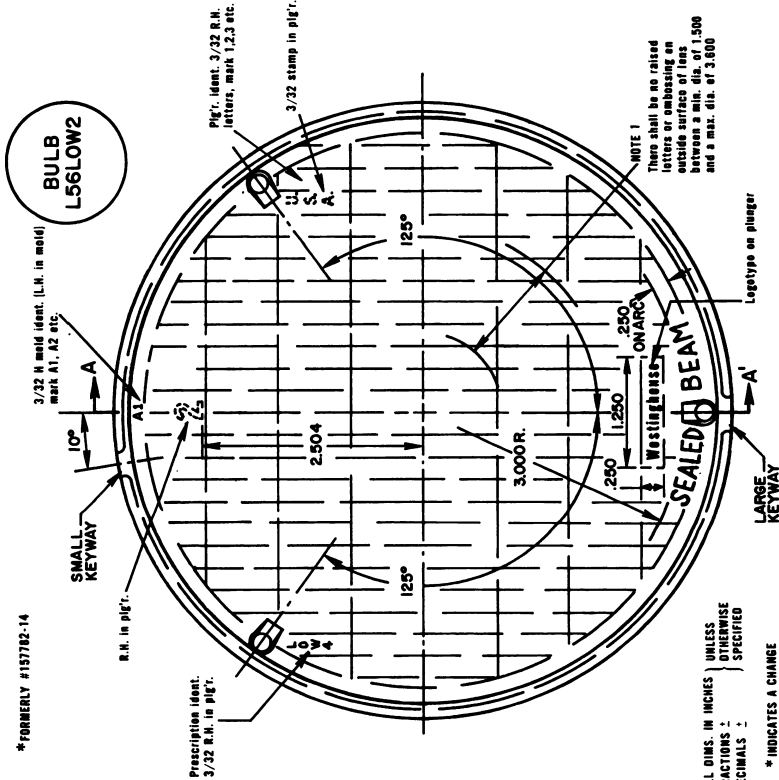

FIGURE B15. Westinghouse 6012 lamp lens design.

This general design (fluting pattern not detailed), with the Westinghouse logo at the bottom of the lens above the words "sealed beam," was used in 6006 and 6012 lamps since 1962 and in 6014 lamps since 1969.

ALL DIMS. IN INCHES UNLESS OTHERWISE SPECIFIED
FRACTIONS ±
DECIMALS ±

* INDICATES A CHANGE

FIGURE B16. Westinghouse 6006 lamp lens detail.
These specifications were valid until at least 1974.

WESTINGHOUSE ELECTRIC CORPORATION
LAMP DIVISION
SPECIFICATION
SPEC. NO. 156782-71
DATE June 15, 1962
SUPERSEDES
DATED

This lens is identical with lens 156782-04 except as shown below

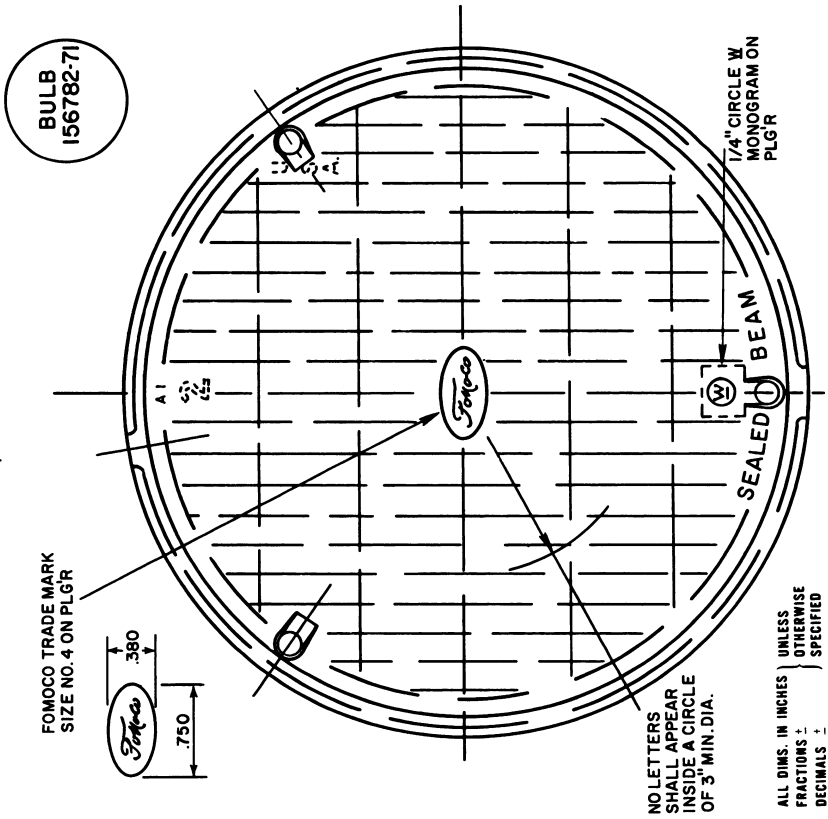

FOMOCO TRADE MARK
SIZE NO. 4 ON PLGR

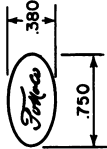

NO LETTERS
SHALL APPEAR
INSIDE A CIRCLE
OF 3" MIN. DIA.

ALL DIMS. IN INCHES
FRACTIONS ± UNLESS
DECIMALS ± OTHERWISE
SPECIFIED

WESTINGHOUSE ELECTRIC CORPORATION
LAMP DIVISION
SPECIFICATION
SPEC. NO. 156782-81
DATE Apr. 27, 1962
SUPERSEDES
DATED

This lens is identical with lens 156782-04 except as shown below.

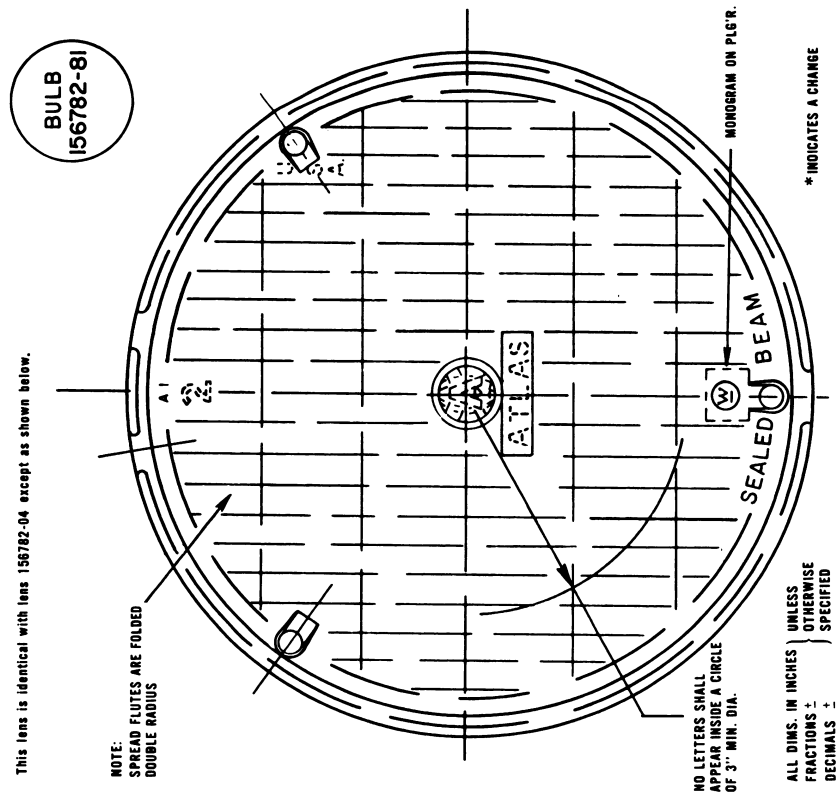

NOTE:
SPREAD FLUTES ARE FOLDED
DOUBLE RADIUS

NO LETTERS SHALL
APPEAR INSIDE A CIRCLE
OF 3" MIN. DIA.

ALL DIMS. IN INCHES
FRACTIONS ± UNLESS
DECIMALS ± OTHERWISE
SPECIFIED

* INDICATES A CHANGE

FIGURE B18. *Westinghouse 4002 lamp lens design.*
This general design (fluting pattern not included) was delisted in 1969.

FIGURE B17. *Westinghouse 4002 lamp lens design.*
This general design (fluting pattern not included) was valid until at least 1971.

WESTINGHOUSE ELECTRIC CORPORATION
LAMP DIVISION
SPECIFICATION

SPEC. NO. MB56AP4C-W Pg.3
DATE Dec. 7, 1959
SUPERSEDES DATED

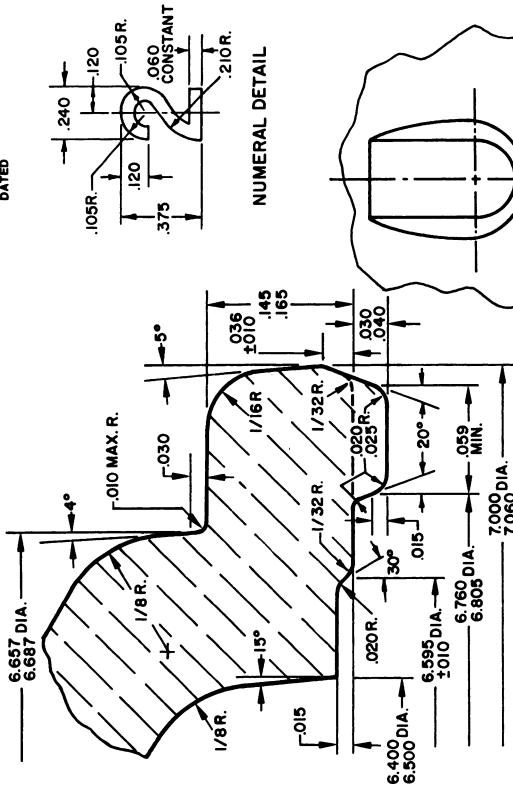

ALL DIMS. IN INCHES
FRACTIONS :
DECIMALS :
* INDICATES A CHANGE
UNLESS OTHERWISE SPECIFIED

FIGURE B20. Westinghouse PAR 56 lamp lens detail.
These specifications were initiated December 1959.

WESTINGHOUSE ELECTRIC CORPORATION
LAMP DIVISION
SPECIFICATION

SPEC. NO. MB56AP3C-W Pg.2
DATE June 17, 1959
SUPERSEDES MB56AP2C-W Pg.2
DATED 4/27/59

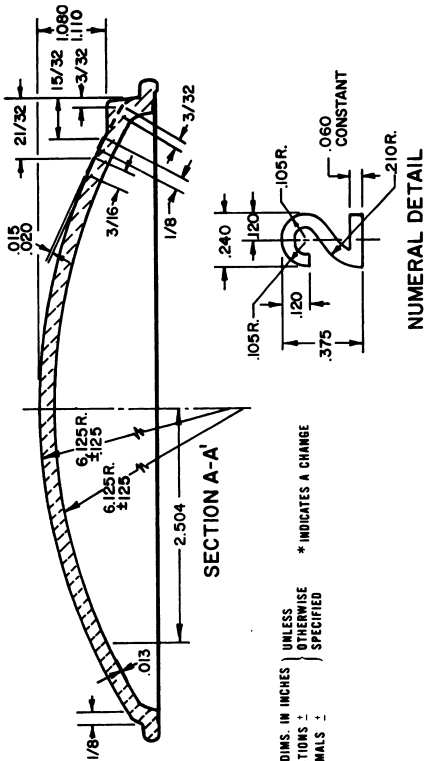

ALL DIMS. IN INCHES
FRACTIONS :
DECIMALS :
* INDICATES A CHANGE
UNLESS OTHERWISE SPECIFIED

* BORDER TO BE .010 THINNER
THAN THINNEST ADJACENT
GLASS AREA

* For lens details not shown,
see MB56F14C-W

FIGURE B19. Westinghouse 6006 lamp lens detail.
These specifications were modified in 1960.

WESTINGHOUSE ELECTRIC CORPORATION
LAMP DIVISION
SPECIFICATION

SPEC. NO. 157782-09 Pg.2
DATE Apr. 27, 1962
SUPERSEDES 157782-01 Pg.2
DATED 9/29/60

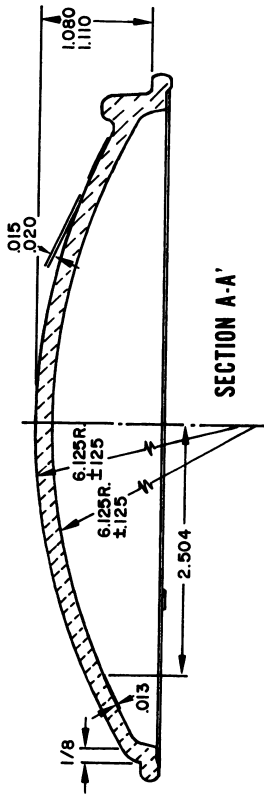

ALL DIMS. IN INCHES } UNLESS OTHERWISE SPECIFIED
FRACTIONS ± }
DECIMALS ± } * INDICATES A CHANGE

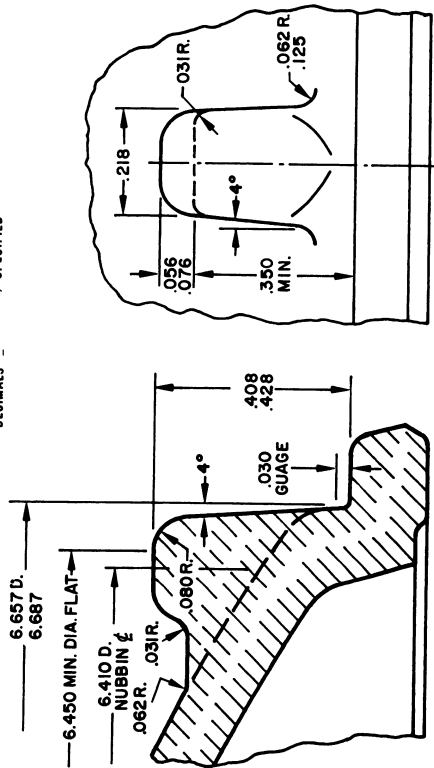

FIGURE B21. Westinghouse PAR 56 lamp lens detail. These specifications were prepared September 1960 and were modified in 1962.

WESTINGHOUSE ELECTRIC CORPORATION
LAMP DIVISION
SPECIFICATION

SPEC. NO. 157782-71
DATE July 7, 1964
SUPERSEDES
DATED

This lens is identical with lens 157782-01 except as shown below

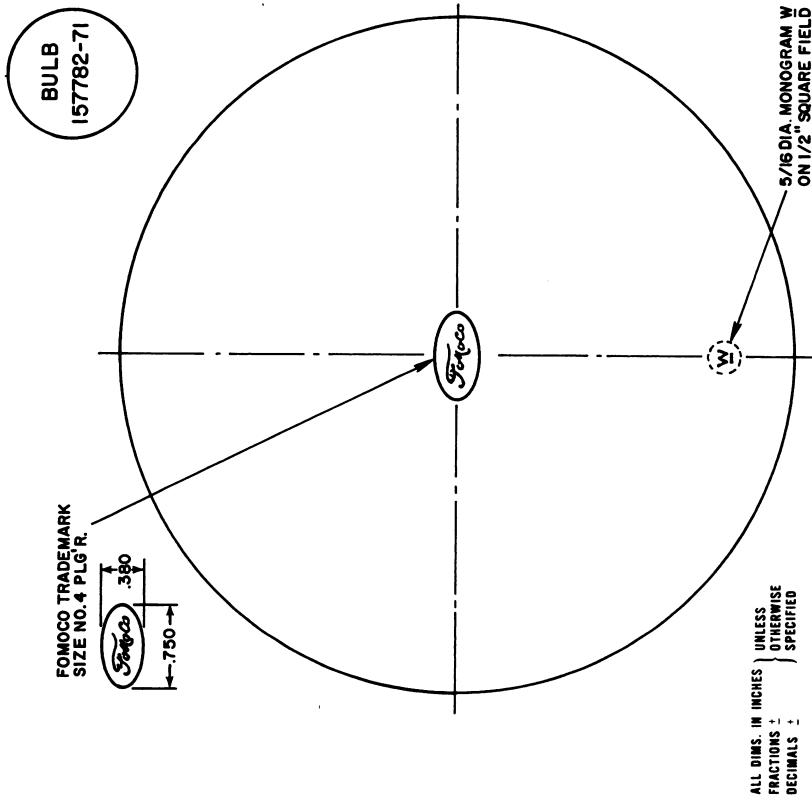
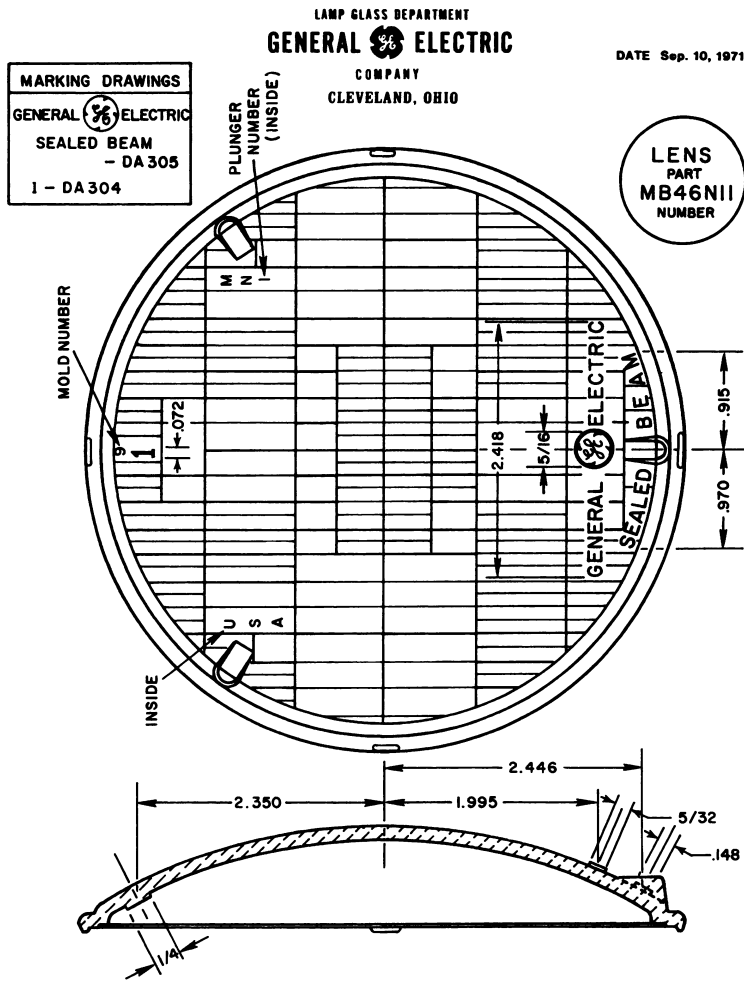

FIGURE B22. Specifications for "FoMoCo" logo to be pressed into Westinghouse 6012 lenses. These specifications were delisted in 1969.

Appendix C—Selected Illustrations of General Electric Headlight Lenses



* INDICATES A CHANGE
ALL DIMENSIONS ARE OUTSIDE
AND IN INCHES

FIGURE C1. General Electric PAR 46 lamp lens design.

LAMP GLASS DEPARTMENT
GENERAL ELECTRIC
 COMPANY
 CLEVELAND, OHIO

DATE July 5, 1970

LENS
 PART
 MB46N4
 NUMBER

MARKING DRAWINGS
 ATLAS - DA416
 GE - DA305-1
 SEALED BEAM
 - DA304
 1 - DA304

PLUNGER
 NUMBER
 (INSIDE)

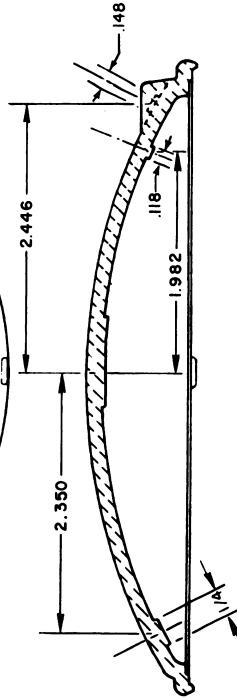
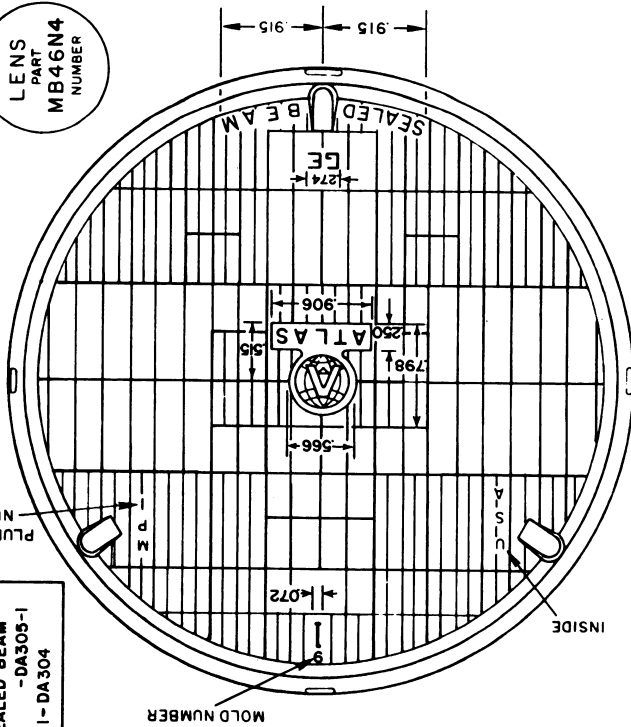

FOR PHYSICAL DIMENSIONS SEE
 LENS DETAIL - MB46-2

* INDICATES A CHANGE
 ALL DIMENSIONS ARE OUTSIDE
 AND IN INCHES

FIGURE C2. General Electric PAR 46 lamp lens design.
 These lenses were made by GE for Atlas Mfg. Corp.

LAMP GLASS DEPARTMENT
GENERAL ELECTRIC
 COMPANY
 CLEVELAND, OHIO

DATE Oct. 10, 1970

LENS
 PART
 MB46P3
 NUMBER

MARKING DRAWINGS
 GENERAL ELECTRIC
 SEALED BEAM
 - DA305
 2 - DA304

PLUNGER
 NUMBER
 (INSIDE)

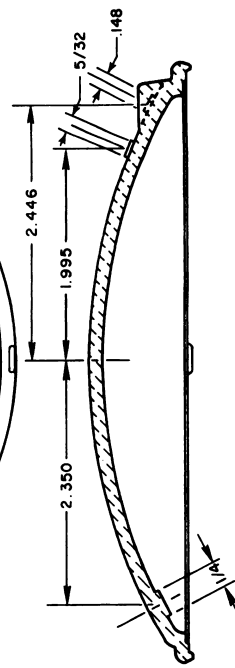
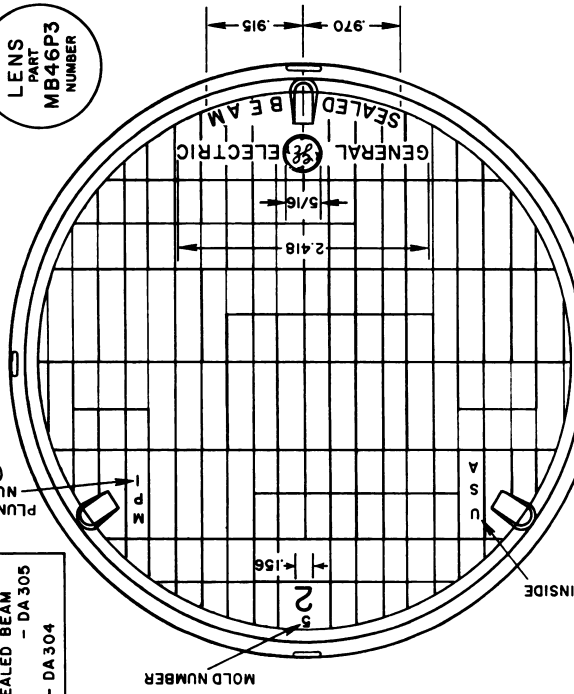

FOR PHYSICAL DIMENSIONS SEE
 LENS DETAIL - MB46-2

* INDICATES A CHANGE
 ALL DIMENSIONS ARE OUTSIDE
 AND IN INCHES

FIGURE C3. Basic logo format for recent G.E. PAR 46 lamps.

GENERAL ELECTRIC
COMPANY
CLEVELAND, OHIO

DATE Sep. 10, 1971

MARKING DRAWINGS
GENERAL ELECTRIC
SEALED BEAM
- DA 305
2 - DA 304

PLUNGER
NUMBER (INSIDE)

LENS
PART
NUMBER
MB46P11

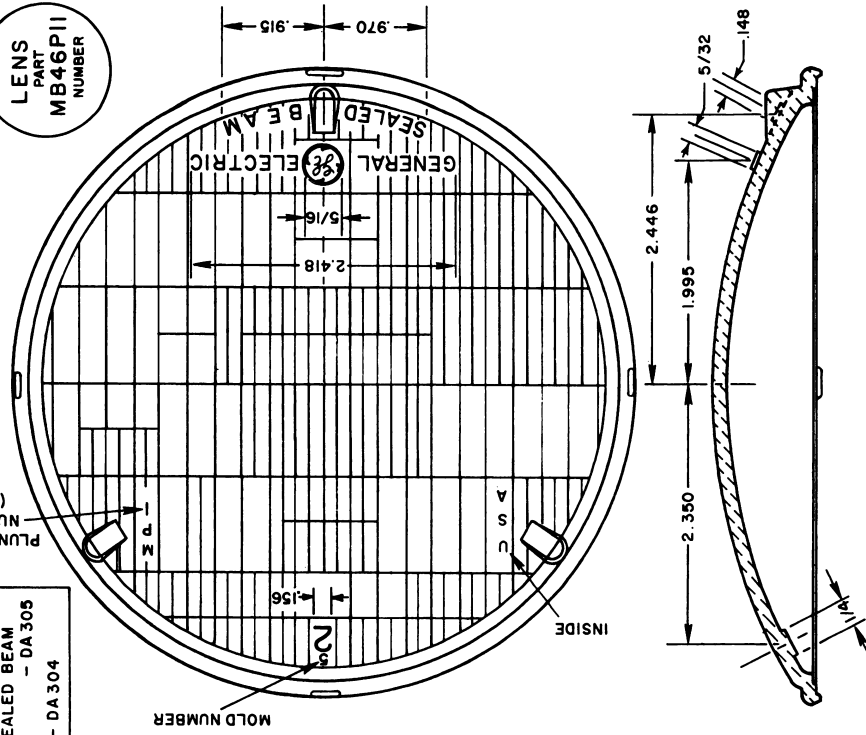

FOR PHYSICAL DIMENSIONS SEE
LENS DETAIL - MB46-5

* INDICATES A CHANGE
ALL DIMENSIONS ARE OUTSIDE
AND IN INCHES

FIGURE C5. General Electric type 4002 lamp lens design.

LAMP GLASS DEPARTMENT
GENERAL ELECTRIC
COMPANY
CLEVELAND, OHIO

DATE March 20, 1971

MARKING DRAWINGS
GENERAL ELECTRIC
SEALED BEAM
- DA 305
2 - DA 304

PLUNGER
NUMBER (INSIDE)

LENS
PART
NUMBER
MB46P8

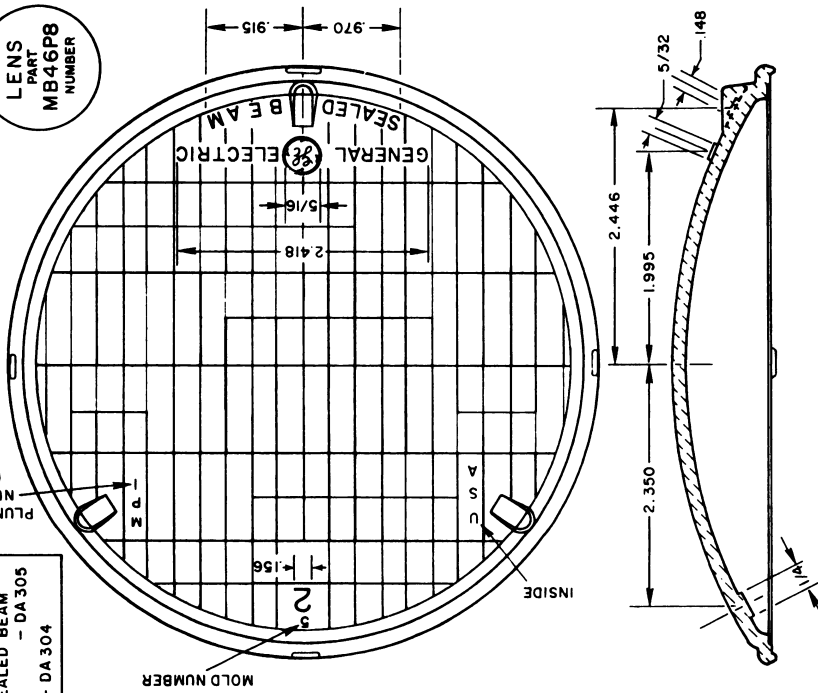

FOR PHYSICAL DIMENSIONS SEE
LENS DETAIL - MB46-5

* INDICATES A CHANGE
ALL DIMENSIONS ARE OUTSIDE
AND IN INCHES

FIGURE C4. General Electric type 4002 lamp lens design.

LAMP GLASS DEPARTMENT
GENERAL ELECTRIC
 COMPANY
 CLEVELAND, OHIO

DATE June 15, 1972

MARKING DRAWINGS
 GENERAL ELECTRIC
 SEALED BEAM
 - DA 305
 2 - DA 304

PLUNGER
 NUMBER (INSIDE)

LENS
 PART
 NUMBER
 MB46PI3

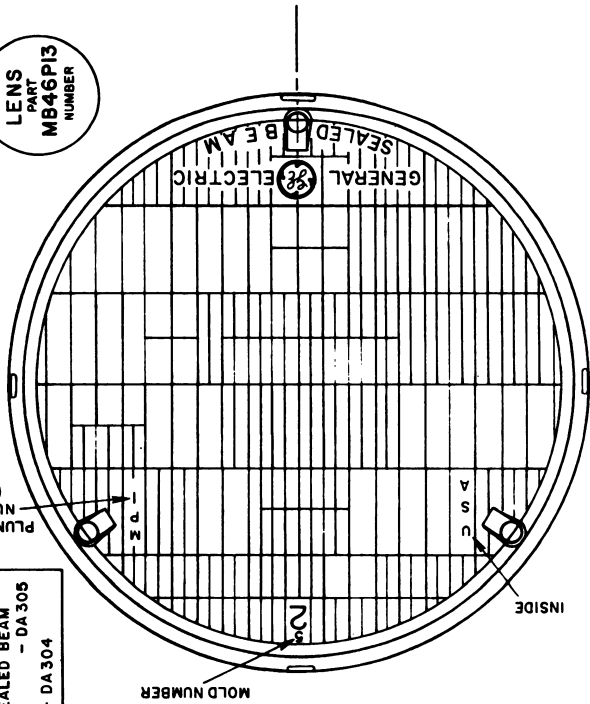

FOR PHYSICAL DIMENSIONS SEE
 LENS DETAIL - MB46-8

* INDICATES A CHANGE
 ALL DIMENSIONS ARE OUTSIDE
 AND IN INCHES

FIGURE C6. General Electric type 4002 lamp lens design.

LAMP GLASS DEPARTMENT
GENERAL ELECTRIC
 COMPANY
 CLEVELAND, OHIO

DATE Oct. 10, 1970

MARKING DRAWINGS
 ATLAS - DA 416
 GE SEALED BEAM
 - DA305-1
 2 - DA 304

PLUNGER
 NUMBER (INSIDE)

LENS
 PART
 NUMBER
 MB46P4

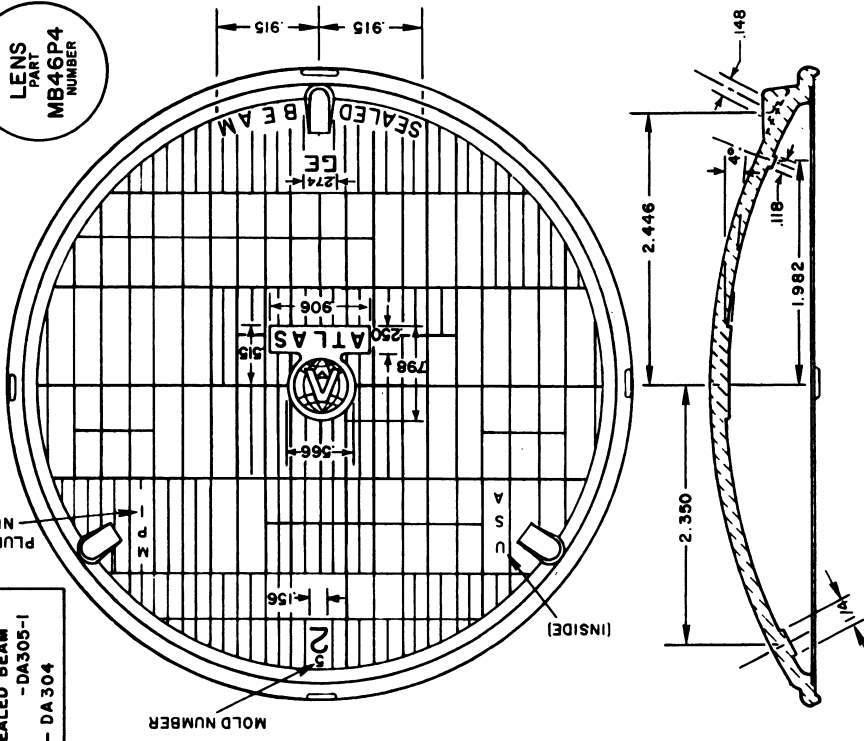

FOR PHYSICAL DIMENSIONS SEE
 LENS DETAIL - MB46-2

* INDICATES A CHANGE
 ALL DIMENSIONS ARE OUTSIDE
 AND IN INCHES

FIGURE C7. Basic logo format for recent Atlas/GE PAR 46 lamps.

EQUIPMENT DRAWINGS
 M - DB1209-2
 P - DB1213
 R - DB1215-1

Numeral 1 to appear for type 1 lenses and numeral 2 to appear for type 2 lenses in upper part of lenses for lenses covered by SAE specifications. Numerals to be 1/4 ± 1/32 high.

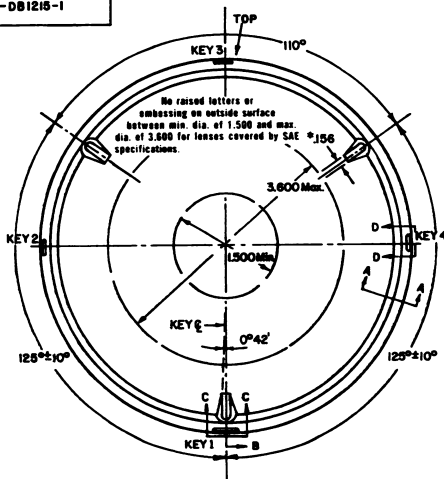

Sealed beam in letters 5/32 ± 1/32 high to appear on lower part of lens for lenses covered by SAE specifications.

* INDICATES A CHANGE
 ALL DIMENSIONS ARE OUTSIDE
 AND IN INCHES

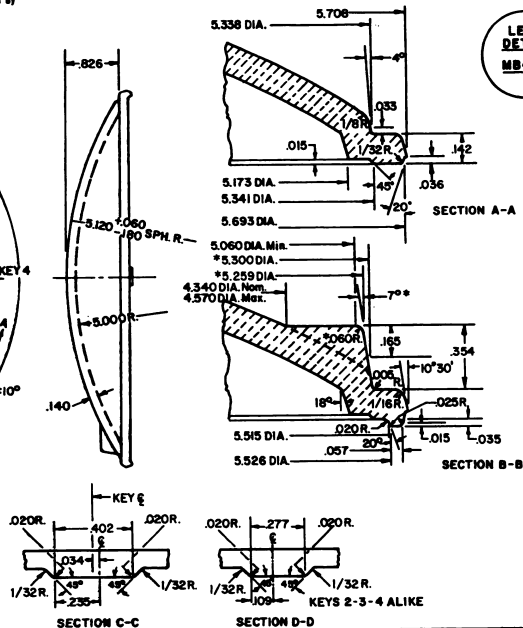

LENS
 DETAIL
 MB46-5

SUPERSEDES
 PART LENS DETAIL
 NUMBER MB 46-5
 DATE Dec. 5, 1970

FIGURE C8. General Electric PAR 46 lamp lens detail.

EQUIPMENT DRAWINGS
 M - DB1209-5
 P - DB1213
 R - DB1215-1

Numeral 1 to appear for type 1 lenses and numeral 2 to appear for type 2 lenses in upper part of lenses for lenses covered by SAE specifications. Numerals to be 1/4 ± 1/32 high.

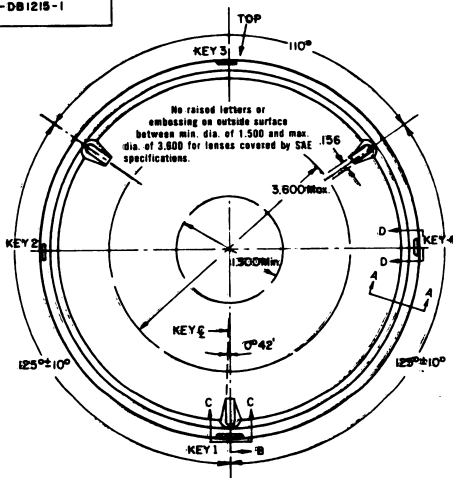

Sealed beam in letters 5/32 ± 1/32 high to appear on lower part of lens for lenses covered by SAE specifications.

* INDICATES A CHANGE
 ALL DIMENSIONS ARE OUTSIDE
 AND IN INCHES

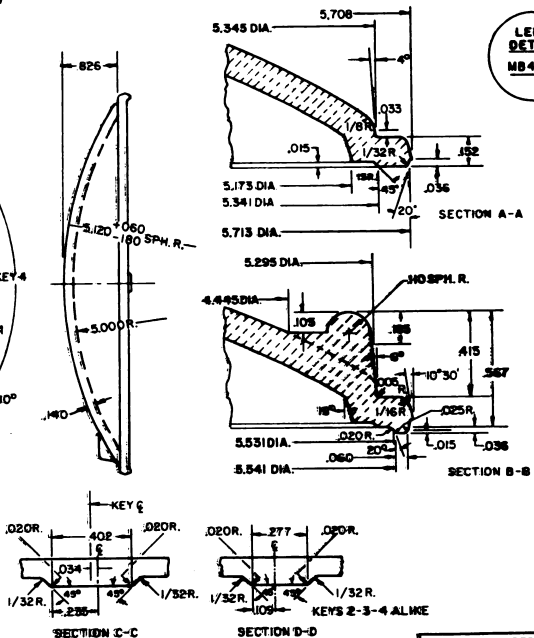

LENS
 DETAIL
 MB46-6

SUPERSEDES
 PART NEW
 NUMBER NEW
 DATE

FIGURE C9. General Electric PAR 46 lamp lens detail.

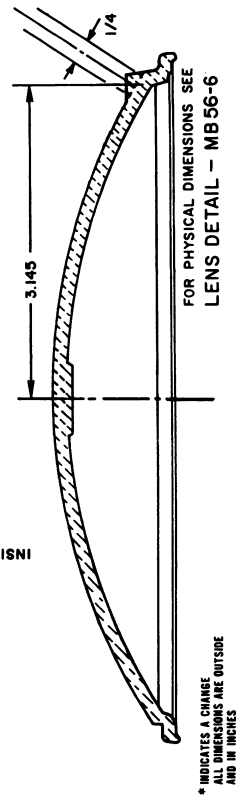
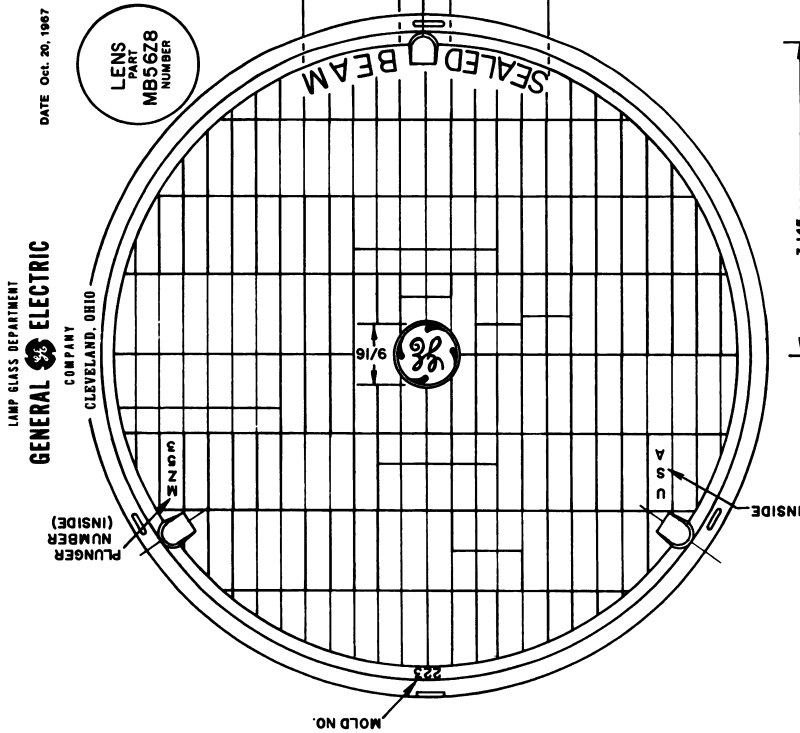

* INDICATES A CHANGE IN DIMENSIONS ARE OUTSIDE AND IN INCHES

FIGURE C10. Basic logo format for C.E. PAR 56 lamps made between 1956 and (?).

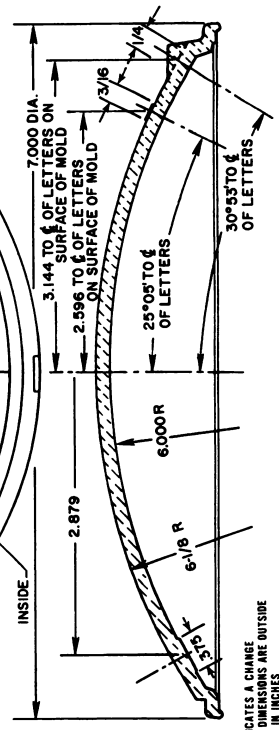
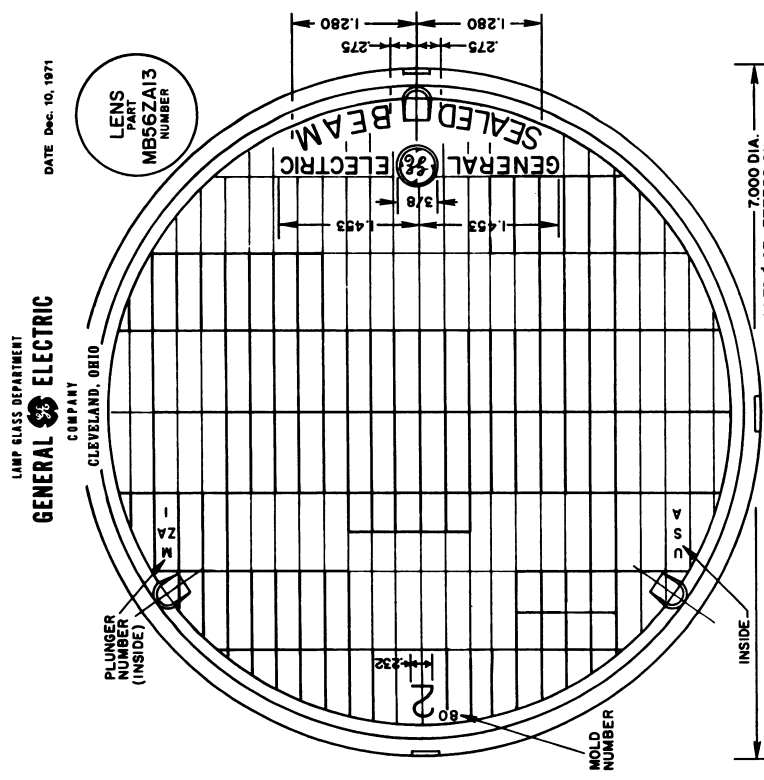

* INDICATES A CHANGE IN DIMENSIONS ARE OUTSIDE AND IN INCHES

FIGURE C11. Basic logo format for recent C.E. PAR 56 lamps.

LAMP GLASS DEPARTMENT
GENERAL ELECTRIC
COMPANY
CLEVELAND, OHIO

DATE June 15, 1972

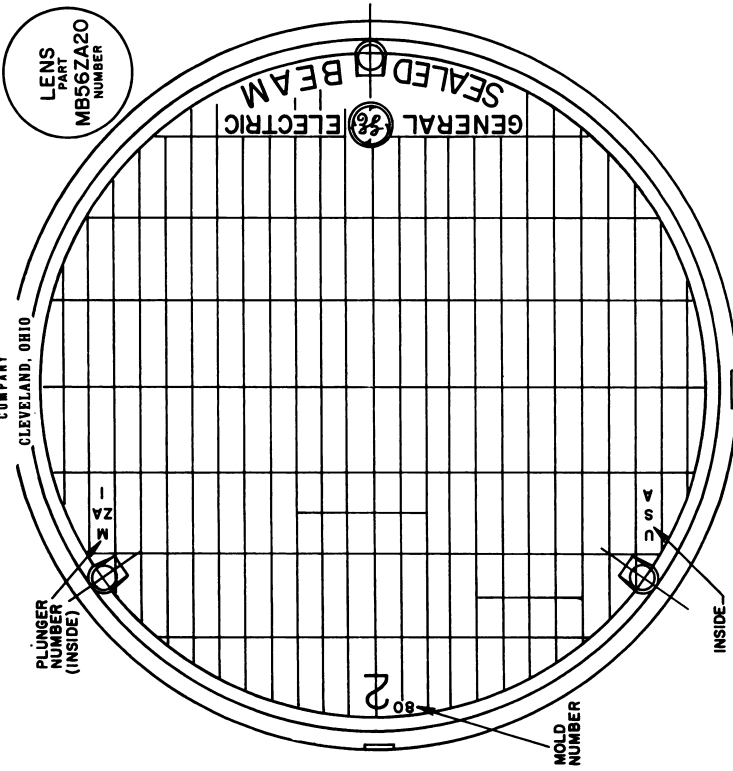

* INDICATES A CHANGE
ALL DIMENSIONS ARE OUTSIDE
AND IN INCHES

FIGURE C12. Basic G.E. PAR 56 lamp lens design prepared June 1972.

LAMP GLASS DEPARTMENT
GENERAL ELECTRIC
COMPANY
CLEVELAND, OHIO

DATE Aug. 25, 1973

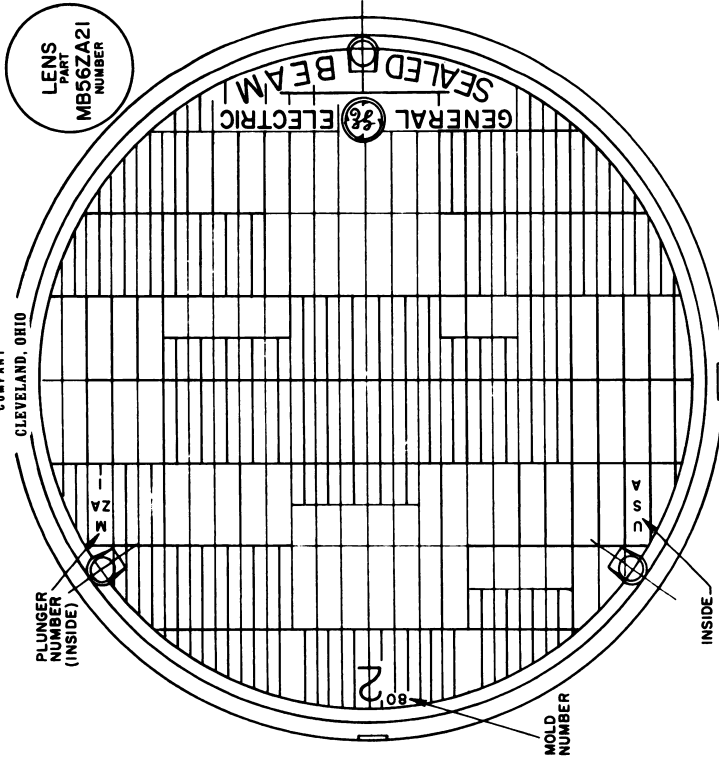

* INDICATES A CHANGE
ALL DIMENSIONS ARE OUTSIDE
AND IN INCHES

FIGURE C13. Basic G.E. PAR 56 lamp lens design prepared August 1973.

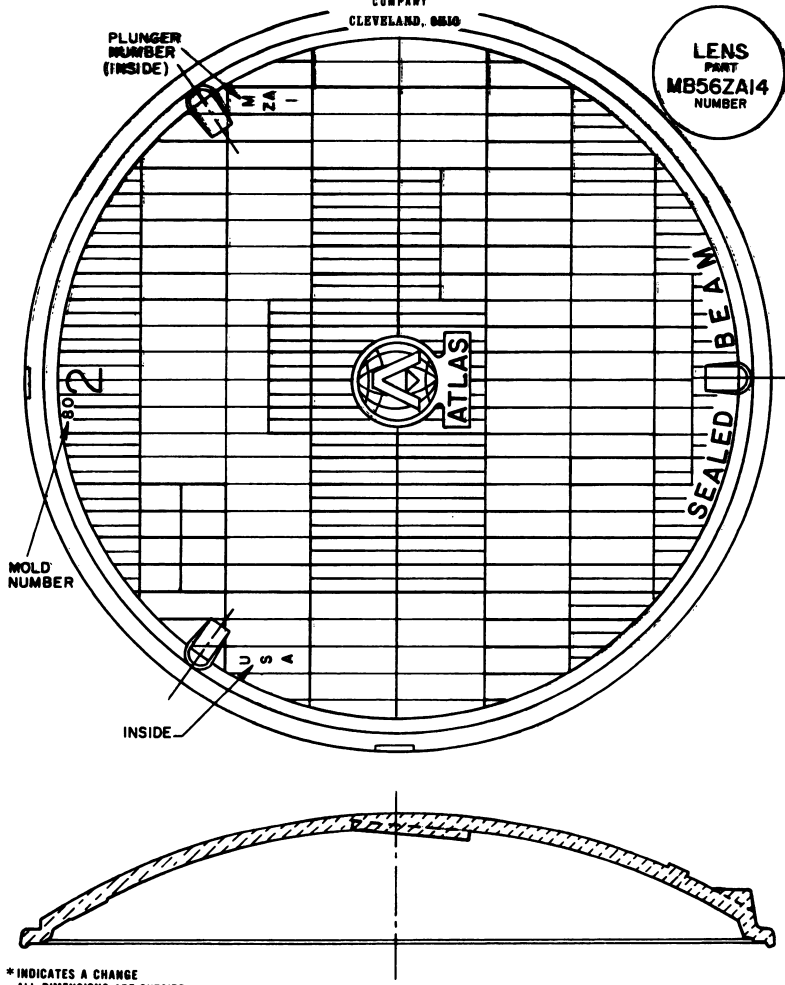

FIGURE C14. G.E. design for PAR 56 lamp lenses pressed for Atlas Mfg. Corp.

EQUIPMENT DRAWINGS
 M-DB1193
 P-DB342
 R-DB1096-2

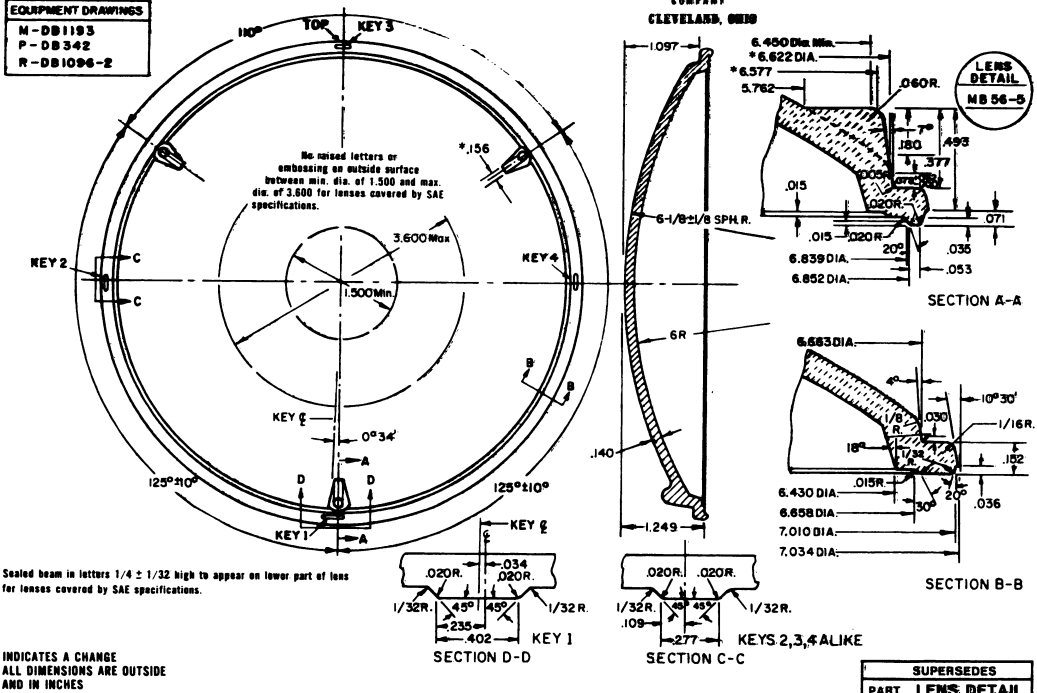

FIGURE C15. G.E. PAR 56 lamp lens detail.

SUPERSEDES
PART
NUMBER MB 56-5
DATE Dec. 5, 1970

EQUIPMENT DRAWINGS
 M-DB1193-4
 P-DB342
 R-DB1096-2

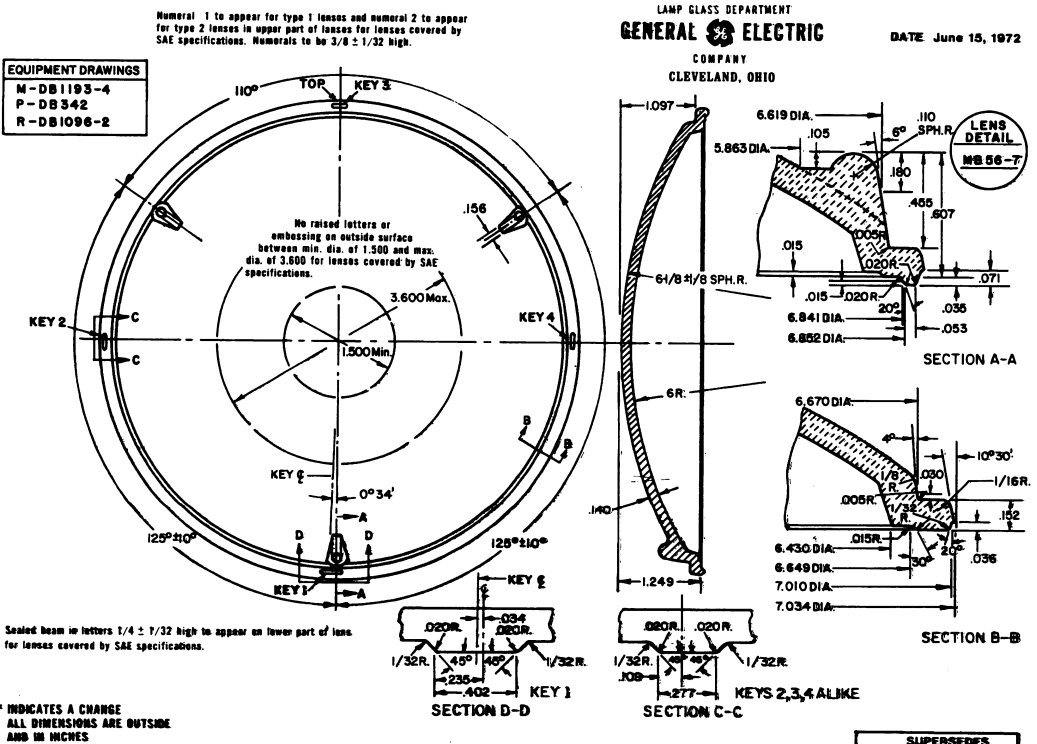

FIGURE C16. G.E. PAR 56 lamp lens detail.
 This modifies specifications in figure C15.

SUPERSEDES
PART
NUMBER NEW
DATE

ANNOUNCEMENT OF NEW PUBLICATIONS ON NATIONAL CRIME AND RELATED SUBJECTS

Superintendent of Documents,
Government Printing Office,
Washington, D.C. 20402

Dear Sir:

Please add my name to the announcement list of new publications to be issued on the above subjects (including this NBS series):

Name _____

Company _____

Address _____

City _____ State _____ Zip Code _____

(Notification Key N-538)

ACKNOWLEDGMENTS

This report was prepared by the Law Enforcement Standards Laboratory of the National Bureau of Standards, under the direction of Robert Mills, Program Manager for Investigative Aids, and Jacob J. Diamond, Chief of LESL.

The author wishes to express his appreciation for the cooperation and assistance of the lamp and glass makers and their industrial representatives. Acknowledgments are also due to the NBS employees who donated headlamps to this project, to Michael Thomas who prepared the lenses for photography, and to Robert Hendrickson who assisted in editing the manuscript.

U.S. DEPARTMENT OF COMMERCE
National Bureau of Standards
Washington, D.C. 20234

OFFICIAL BUSINESS

Penalty for Private Use, \$300

POSTAGE AND FEES PAID
U.S. DEPARTMENT OF COMMERCE
COM-215



SPECIAL FOURTH-CLASS RATE
BOOK
